



QUICK COUPLINGS

INTRODUCTION

Q.Safe is the Manuli Hydraulics offering for quick coupling applications. Composed of an ever-expanding range of products, the Q.Safe brand has rapidly become an industry byword for quality and performance. The entire Q.Safe product range is manufactured with our E-Coat 500 treatment which provides an environmentally friendly surface coating (chrome free) far exceeding ISO 4520 requirements (salt spray resistance: 240 hours for white corrosion and 500 for red corrosion). Some Q.Safe products also have the option to upgrade to our new E-Coat 1000 plating which offers 1,000 hours to red corrosion (see page 96 for details).

Guaranteeing leak-free performance, the Q.Safe brand is suitable for a wide range of different applications and assures total interchangeability with other quick coupling products on the market. All Q.Safe products are manufactured and assembled in our world-class facility, where they are subjected to stringent quality controls including:

- 100% visual check
- 100% functional test
- 100% air sealing test

Manuli Hydraulics Q.Safe are suggested for the following application fields:

AGRICULTURE AND FORESTRY (TRACTORS, TRAILERS, HARVESTER MACHINES)

- Quick couplings according to ISO 7241-A standard connectable in whatever pressure conditions:
- MQS-A and MQS-AF, MQS-N in case of no pressure in the hydraulic line.
- MQS-AP, MQS-AFP, MQS-AFM, MQS-AFB, MQS-ARM and MQS-ARB in case of pressure in one or both the hydraulic lines.
- Quick couplings for hydraulic braking systems: MQS-VB according to ISO 5676 standard, MQS-VS
- Flat Face Quick couplings according to ISO 16028 standards: MQS-F, MQS-FP, MQS-FS
- Screw-type couplings: MQS-SG, MQS-SGR
- Quick couplings for diagnosis according to ISO 15171-1 standard: MQS-D
- Quick couplings “direct hose integration”: MQS-DHI
- Check valves: MQS-CV, MQS-CVC

MINING (DRILLS)

- MQS-A, MQS-N
- MQS-F
- MQS-SG, MQS-SGR
- MQS-SC
- MQS-SH
- MQS-CV, MQS-CVC

CONSTRUCTION EQUIPMENTS AND UTILITY VEHICLES (EXCAVATORS, SKID STEERS LOADERS, WHEEL-LOADERS, HYDRAULIC TOOLS AND DUMP TRAILERS)

- MQS-A, MQS-AF, MQS-N, MQS-B
- MQS-F, MQS-FP, MQS-FS
- MQS-SG, MQS-SGR
- MQS-D
- Screw type couplings for very high static pressure: MQS-SC
- Screw type couplings for extreme working conditions: MQS-SH
- Wing nut screw type couplings: MQS-ST
- MQS-DHI
- MQS-CV, MQS-CVC

OIL & GAS

- MQS-SO
- MQS-BOP

INDUSTRY

- MQS-F
- MQS-SH
- MQS-B
- MQS-D
- MQS-DHI
- MQS-CV, MQS-CVC

QUICK COUPLING SELECTION

To ensure that you select the correct quick coupling for your needs, Manuli Hydraulics recommends that the following factors be considered:

Pressure and Flow Rate - The selected quick coupling must always be suitable for the pressure and flow rate in the system. Always check that the selected quick coupling's maximum working pressure is equal to or greater than the maximum pressure of the system (including pressure spikes).

Connection Under Pressure - Many quick couplings can only be connected / disconnected when the line pressure has been reduced to zero. If this is not possible you should select a quick coupling which is connectible under pressure. When disconnecting couplings the line pressure must be reduced to zero. Avoid using tools to connect / disconnect quick couplings.

Fluid Compatibility - Always check that the fluids used are compatible with the materials and seals used in the quick couplings.

Temperature - Always verify that the maximum working temperature of the system is within the operational limits of the quick coupling selected.

Environmental Conditions - Be aware that certain environmental conditions can cause damage or excessive corrosion to the quick couplings. Some specific examples are environments where there are harsh chemicals, UV radiation or salt waters.

GENERAL PRECAUTIONS

- Before connecting the quick coupling carefully clean the insert in order to prevent excessive wear on seals.
- Use suitable protective components such as plugs and caps when quick couplings are not in use to prevent unnecessary wear or damage.
- Shock impacts, such as falling on the ground, may damage your quick coupling. Take precautions to avoid this kind of impact.
- Replace damaged / worn O-rings and back-up rings as soon as possible using the recommended spare part kits.
- Inspect each quick coupling after every individual application in order to detect any visible cracks, leakage, damage or corrosion.

MQS-DHI “DIRECT HOSE INTEGRATION”

An innovative system to enable direct assembly of the quick-release coupling to the flexible hose, and therefore avoiding intermediate connection elements.

Some of the benefits of this solution are:

- Reduced risk of oil leakage
- Elimination of unscrewing problems in the field
- Reduction in the number of assembly elements leading to reduced assembly cost, minimised risk of assembly operation mistakes and greater safety in severe working conditions, as well as easier maintenance and replacement operations

Design solutions are available for most common series ISO A, ISO B, Push-Pull & Flat-Face

DHI quick release coupling maintenance is possible without the need to replace the flexible hose.

Q.SAFE FLAT FACE MULTICONNECTORS

The Q.Safe quick coupling range is widely renowned for representing the Gold Standard in quick coupling quality and performance. The introduction of the Q.Safe Flat Face Multiconnector range combines this superior performance with the added efficiency and safety related benefits of a multiconnector block system.

- Reduces connection time when multiple connectors are used
- No risk of incorrect connection
- No misalignment between mobile and static blocks
- Compact design for minimal added weight
- Flat face couplings allow high pressures (350 bar) and high flow rates
- Allows hoses to be arranged closer together whilst still allowing easy access
- Industry leading performance with reduced pressure drop
- Almost zero (between 0.007cc and 0.009cc) oil spillage on connection / disconnection
- Connection under residual pressure
- Easy to clean

Q.SAFE QUICK COUPLINGS

QUICK COUPLINGS SERIES	DESCRIPTION	FEMALE	MALE	SHUT-OFF SYSTEM	SPECIFICATIONS	CONNECTION	SIZE										PAGE No.		
							1/8"	1/4"	3/8"	1/2"	5/8"	3/4"	1"	1 1/4"	1 1/2"	2"			
MQS-A	ISO A	Q008	Q002	POPPET VALVE	ISO 7241 SERIES A	LOCKING BALLS													341
			Q004	SHIELDED POPPET															
		Q009	Q003	BALL VALVE															
MQS-AP	ISO A CONNECTABLE UNDER PRESSURE	Q010	Q006	POPPET VALVE	ISO 7241 SERIES A	LOCKING BALLS													352
MQS-AM	ISO A CONNECTABLE WITH MALE UNDER PRESSURE	Q011	-	POPPET VALVE	ISO 7241 SERIES A	LOCKING BALLS													354
MQS-AB	ISO A CONNECTABLE WITH BOTH PARTS UNDER PRESSURE	Q012	-	POPPET VALVE	ISO 7241 SERIES A	LOCKING BALLS													356
MQS-B	ISO B	Q024	Q021	POPPET VALVE	ISO 7241 SERIES B	LOCKING BALLS													358
MQS-BOP	ISO B FOR DRILLING BOP UNIT	Q026 F	Q021 F	POPPET VALVE	ISO 7241 SERIES B + FLAME TEST RES. TO API 16D	LOCKING BALLS													361
MQS-N	STANDARD	Q032	Q029	POPPET VALVE	-	LOCKING BALLS													363
		Q033	Q030	BALL VALVE															
MQS-NL	FREE-FLOW	Q038	Q037	WITHOUT	-	LOCKING BALLS													369
MQS-NF	STANDARD PUSH-PULL	Q036	-	POPPET VALVE	-	LOCKING BALLS													371
MQS-AF	PUSH-PULL	Q013	-	POPPET VALVE	ISO 7421 SERIES A	LOCKING BALLS													373
MQS-AFP	PUSH-PULL CONNECTABLE UNDER PRESSURE	Q015	-	POPPET VALVE	ISO 7421 SERIES A	LOCKING BALLS													380
MQS-AFM	PUSH-PULL, CONNECTABLE WITH MALE UNDER PRESSURE, FLEXIBLE MOUNTING	Q016	-	POPPET VALVE	ISO 7421 SERIES A	LOCKING BALLS													382
MQS-AFB	PUSH-PULL CONNECTABLE WITH MALE UNDER PRESSURE, FLEXIBLE MOUNTING	Q017	-	POPPET VALVE	ISO 7421 SERIES A	LOCKING BALLS													384
MQS-ARM	PUSH-PULL, CONNECTABLE WITH MALE UNDER PRESSURE, RIGID MOUNTING	Q018	-	POPPET VALVE	ISO 7421 SERIES A	LOCKING BALLS													386
MQS-ARB	PUSH-PULL CONNECTABLE WITH BOTH PARTS UNDER PRESSURE, RIGID MOUNTING	Q019	-	POPPET VALVE	ISO 7421 SERIES A	LOCKING BALLS													390
MQS-VB	BRAKING CIRCUIT VALVE	Q048	Q047	FLAT VALVE	ISO 5676	LOCKING BALLS													395
MQS-VS	AGRICULTURAL VALVE	Q050	Q049	FLAT VALVE	-	SCREW-ON SLEEVE													401

Q.SAFE 338

Q.SAFE MULTICONNECTORS

MULTI-COUPLING SERIES	CONFIGURATION	NO. OF LINES	SIZE			PAGE No.
			DN	inch	Dash	
Q401		2	10	3/8"	-06	472
Q402		2	12.5	1/2"	-08	473
Q403		4	10	3/8"	-06	474
Q404		4	12.5	1/2"	-08	475
Q405		2	10	3/8"	-06	476
Q406		2	12.5	1/2"	-08	477
		2	19	3/4"	-12	

MULTI-COUPLING SERIES	CONFIGURATION	NO. OF LINES	SIZE			PAGE No.
			DN	inch	Dash	
Q407		6	10	3/8"	-06	478
Q408		6	12.5	1/2"	-08	479
Q409		8	12.5	1/2"	-08	480
Q410		4	12.5	1/2"	-08	481
Q411		4	10	3/8"	-06	482

Q.SAFE 340

Q.SAFE ACCESSORIES

ACCESSORY TYPE	SIZE										PAGE No.
	1/8"	1/4"	3/8"	1/2"	5/8"	3/4"	1"	1 1/4"	1 1/2"	2"	
PARKING											485
PLUGS & CAPS											487
SPARE PARTS											496



ISO A POPPET VALVES

Pressure Drop

Pressure Drop

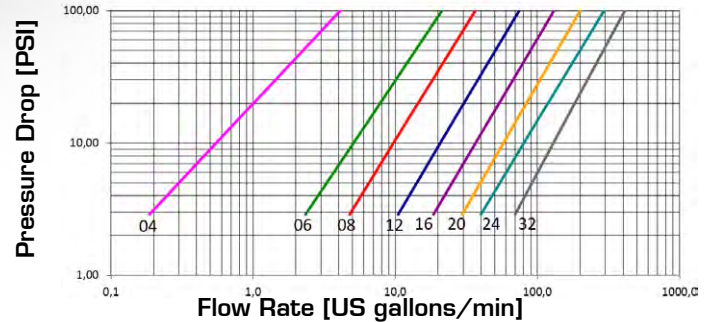
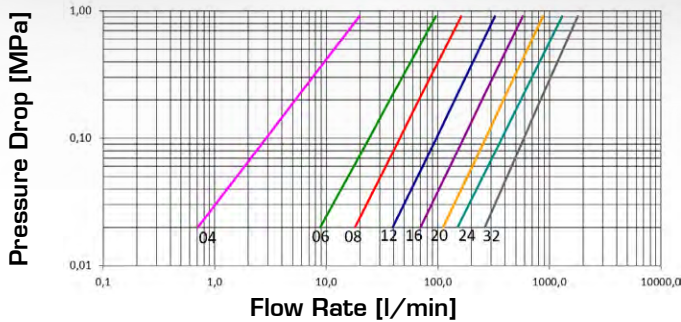

TECHNICAL DATA

SIZE			MPa		FLOW RATE		N		OIL SPILLAGE		MINIMUM BURST PRESSURE						CONNECTION / DISCONNECTION UNDER PRESSURE
DN	inch	Dash	MPa	PSI	l/min	US GPM	N	lb.	cc.	cubic inch	Male		Female		M & F		
											MPa	PSI	MPa	PSI	MPa	PSI	
6.3	¼	04	35	5075	5	1.3	60	13.5	0.7	0.043	200	29000	150	21750	150	21750	Not allowed
10	⅜	06	35	5075	37	9.2	80	18.0	1.4	0.085	140	20300	150	21750	150	21750	Not allowed
12.5	½	08	30	4350	68	19.8	80	18.0	2	0.122	125	18125	150	21750	150	21750	Not allowed
20	¾	12	25	3625	142	38.8	90	20.2	7	0.427	100	14500	120	17400	100	14500	Not allowed
25	1	16	25	3625	250	66.1	90	20.2	11	0.671	100	14500	100	14500	100	14500	Not allowed
31.5	1¼	20	25	3625	390	103.0	90	20.2	15	0.915	100	14500	100	14500	105	15225	Not allowed
40	1½	24	22	3190	553	146.1	100	22.5	21	1.281	90	13050	100	14500	100	14500	Not allowed
51	2	32	15	2175	838	221.4	225	50.6	45	2.746	60	8700	60	8700	90	13050	Not allowed

The rated flow represents the normal operating condition. The maximum recommended flow rate is equal to 1.5 times the rated flow

PRODUCT DESCRIPTION

- Reference series on the agriculture and industrial market
- Simple connection and disconnection by pulling back the sleeve
- Positive, quick connection of the male into the female by the latching ball system
- Shut-off by poppet valve
- High resistant materials and hardened male and sleeve to withstand the brinelling effect
- Interchangeability according to ISO 7241 series A

MATERIAL

Female and male couplings in steel, with some hardened areas, in correspondence to the most stressed points. Springs in C98 steel, seals in NBR (other materials on request) and back-up ring in PTFE. PU seal on ½" female available on request.

WORKING TEMPERATURE

-22°F up to +230°F (-30°C up to +110°C)
For other temperatures, the coupling may be assembled with the specific seals

SAFETY FACTOR

4:1 for dynamic pressures

IMPULSE PRESSURES

100,000 cycles at 133% of the rated one (freq. 1Hz)

TEST SPECIFICATIONS

ISO 18869

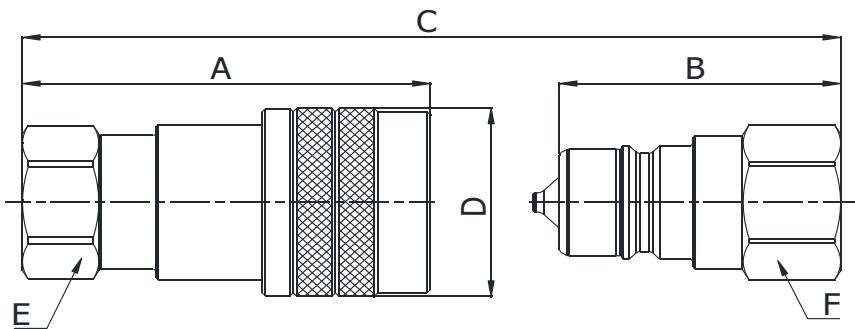

Q00811021A
Q00211021A

BSPT TERMINATION ENDS
TO ISO 7-1
TAPERED

SIZE			PART NUMBER		THREAD	DIMENSIONS mm					
DN	Inch	Dash	Female coupling	Male coupling		A	B	C	D	E	F
6.3	1/4"	-04	Q00811021A-04-04	Q00211021A-04-04	1/4"	48.8	34.5	A+B-14,3	ø24	17	17
10	3/8"	-06	Q00811021A-06-06	Q00211021A-06-06	3/8"	57.8	40	A+B-17,8	ø30	22	22
12.5	1/2"	-08	Q00811021A-08-08	Q00211021A-08-08	1/2"	67.1	45	A+B-22,1	ø38	27	27
20	3/4"	-12	Q00811021A-12-12	Q00211021A-12-12	3/4"	83.5	56.5	A+B-27	ø45	34	34
25	1"	-16	Q00811021A-16-16	Q00211021A-16-16	1"	97.9	64.5	A+B-32,7	ø52,3	41	41

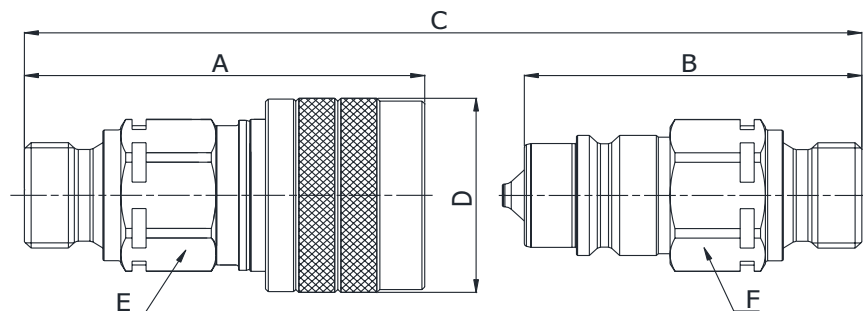

Q00811050A
Q00211050A

BSP TERMINATION ENDS
TO ISO 8434-6

SIZE			PART NUMBER		THREAD	DIMENSIONS mm					
DN	Inch	Dash	Female coupling	Male coupling		A	B	C	D	E	F
10	3/8"	-06	Q00811050A-06-06	Q00211050A-06-06	3/8"	64.7	56.2	A+B-17,5	ø30	22	22
12.5	1/2"	-08	Q00811050A-08-06	Q00211050A-08-06	3/8"	68.9	57.7	A+B-21,8	ø38	27	27
12.5	1/2"	-08	Q00811050A-08-08	Q00211050A-08-08	1/2"	71.4	60.2	A+B-21,8	ø38	27	27

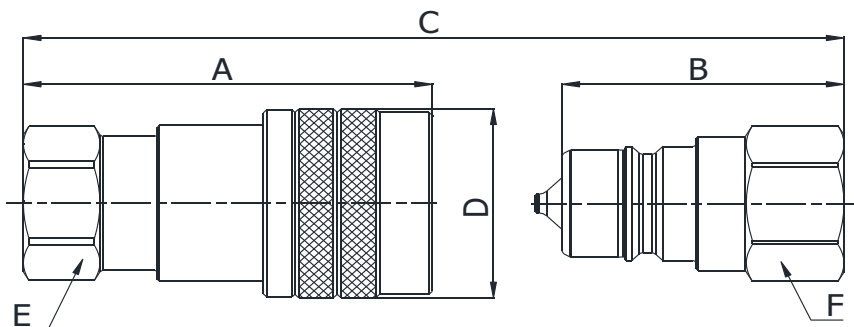

Q00811041A
Q00211041A

BSP TERMINATION ENDS
TO DIN 3852 X TYPE

SIZE			PART NUMBER		THREAD	DIMENSIONS mm					
DN	Inch	Dash	Female coupling	Male coupling		A	B	C	D	E	F
6.3	1/4"	-04	Q00811041A-04-04	Q00211041A-04-04	1/4"	48.8	34.5	A+B-14,2	ø24	17	17
10	3/8"	-06	Q00811041A-06-04	Q00211041A-06-04	1/4"	63	54.5	A+B-17,5	ø30	22	22
10	3/8"	-06	Q00811041A-06-06	Q00211041A-06-06	3/8"	57.8	40	A+B-17,5	ø30	22	22
12.5	1/2"	-08	Q00811041A-08-06	Q00211041A-08-06	3/8"	66.2	55	A+B-21,8	ø38	27	27
12.5	1/2"	-08	Q00811041A-08-08	Q00211041A-08-08	1/2"	67	45	A+B-21,8	ø38	27	27
12.5	1/2"	-08	Q00811041A-08-12	Q00211041A-08-12	3/4"	69	53	A+B-21,8	ø38	34	34
20	3/4"	-12	Q00811041A-12-08	Q00211041A-12-08	1/2"	85.7	66.3	A+B-26,7	ø45	34	34
20	3/4"	-12	Q00811041A-12-12	Q00211041A-12-12	3/4"	83.5	56.5	A+B-26,7	ø45	34	34
25	1"	-16	Q00811041A-16-12	Q00211041A-16-12	3/4"	97.9	64.5	A+B-32,7	ø52	41	41
25	1"	-16	Q00811041A-16-16	Q00211041A-16-16	1"	97.9	64.5	A+B-32,7	ø52	41	41
31.5	1.1/4"	-20	Q00811041A-20-20	Q00211041A-20-20	1.1/4"	118	75	A+B-43	ø69	50	50
40	1.1/2"	-24	Q00811041A-24-24	Q00211041A-24-24	1.1/2"	133	84	A+B-49	ø83	60	60
51	2"	-32	Q00811041A-32-32	Q00211041A-32-32	2"	164	104	A+B-60,2	ø100	75	75

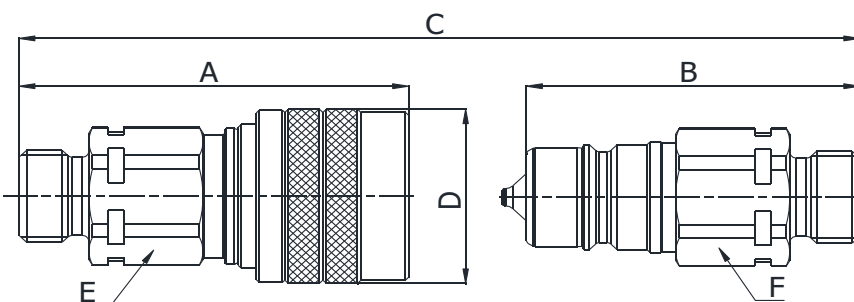

Q00811110A
Q00211110A

METRIC TERMINATION ENDS
TO ISO 8434-1
L SERIES

SIZE			PART NUMBER		THREAD	DIMENSIONS mm					
DN	Inch	Dash	Female coupling	Male coupling		A	B	C	D	E	F
6.3	1/4"	-04	Q00811110A-04-14	Q00211110A-04-14	M14x1,5	52.1	42	A+B-14,2	ø24	17	17
10	3/8"	-06	Q00811110A-06-12	Q00211110A-06-12	M12x1,5	61	52.5	A+B-17,5	ø30	22	22
10	3/8"	-06	Q00811110A-06-14	Q00211110A-06-14	M14x1,5	61	52.5	A+B-17,5	ø30	22	22
10	3/8"	-06	Q00811110A-06-16	Q00211110A-06-16	M16x1,5	61	52.5	A+B-17,5	ø30	22	22
10	3/8"	-06	Q00811110A-06-18	Q00211110A-06-18	M18x1,5	61	52.5	A+B-17,5	ø30	22	22
12.5	1/2"	-08	Q00811110A-08-14	Q00211110A-08-14	M14x1,5	65.2	54	A+B-21,8	ø38	27	27
12.5	1/2"	-08	Q00811110A-08-16	Q00211110A-08-16	M16x1,5	66.2	55	A+B-21,8	ø38	27	27
12.5	1/2"	-08	Q00811110A-08-18	Q00211110A-08-18	M18x1,5	65.2	54	A+B-21,8	ø38	27	27
12.5	1/2"	-08	Q00811110A-08-22	Q00211110A-08-22	M22x1,5	66.2	55	A+B-21,8	ø38	27	27
12.5	1/2"	-08	Q00811110A-08-26	Q00211110A-08-26	M26x1,5	66.2	55	A+B-21,8	ø38	27	27
20	3/4"	-12	Q00811110A-12-18	Q00211110A-12-18	M18x1,5	85.4	66.3	A+B-26,7	ø45	34	34
20	3/4"	-12	Q00811110A-12-22	Q00211110A-12-22	M22x1,5	85.7	66.3	A+B-26,7	ø45	34	34
20	3/4"	-12	Q00811110A-12-26	Q00211110A-12-26	M26x1,5	85.7	66.3	A+B-26,7	ø45	34	34
20	3/4"	-12	Q00811110A-12-30	Q00211110A-12-30	M30x2	87.7	68.3	A+B-26,7	ø45	34	34
25	1"	-16	Q00811110A-16-26	Q00211110A-16-26	M26x1,5	94.5	79.5	A+B-32,7	ø52	41	41
25	1"	-16	Q00811110A-16-30	Q00211110A-16-30	M30x2	96.5	81.5	A+B-32,7	ø52	41	41
25	1"	-16	Q00811110A-16-36	Q00211110A-16-36	M36x2	97	81.5	A+B-32,7	ø52	41	41

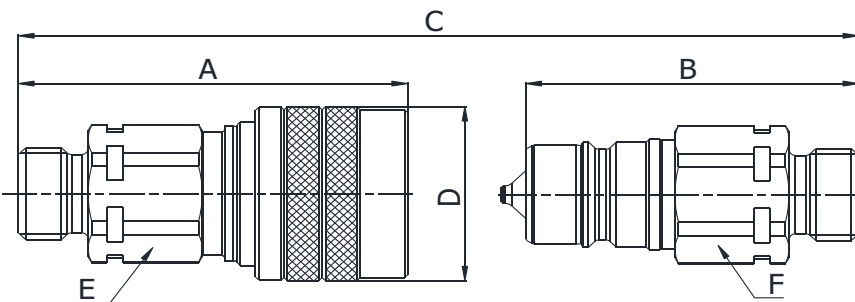

Q00811120A
Q00211120A

METRIC TERMINATION ENDS
TO ISO 8434-1
S SERIES

SIZE			PART NUMBER		THREAD	DIMENSIONS mm					
DN	Inch	Dash	Female coupling	Male coupling		A	B	C	D	E	F
10	3/8"	-06	Q00811120A-06-16	Q00211120A-06-16	M16x1,5	62	53.5	A+B-17,5	ø30	22	22
10	3/8"	-06	Q00811120A-06-18	Q00211120A-06-18	M18x1,5	62	53.5	A+B-17,5	ø30	22	22
12.5	1/2"	-08	Q00811120A-08-18	Q00211120A-08-18	M18x1,5	66.2	55	A+B-21,8	ø38	27	27
12.5	1/2"	-08	Q00811120A-08-20	Q00211120A-08-20	M20x1,5	66.2	55	A+B-21,8	ø38	27	27
12.5	1/2"	-08	Q00811120A-08-24	Q00211120A-08-24	M24x1,5	68.2	57	A+B-21,8	ø38	27	27
25	1"	-16	Q00811120A-16-30	Q00211120A-16-30	M30x2	98.5	83.5	A+B-32,7	ø52	41	41
25	1"	-16	Q00811120A-16-36	Q00211120A-16-36	M36x2	100.5	85.5	A+B-32,7	ø52	41	41
25	1"	-16	Q00811120A-16-42	Q00211120A-16-42	M40x2	102.5	87.5	A+B-32,7	ø52	46	46

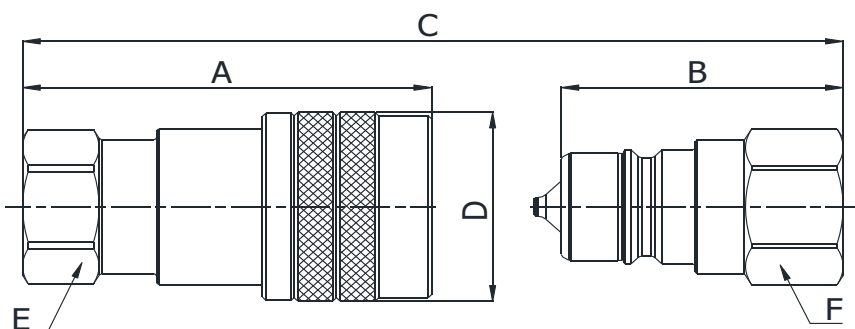

Q00811191A
Q00211191A

METRIC TERMINATION ENDS
TO ISO 6149-1

SIZE			PART NUMBER		THREAD	DIMENSIONS mm					
DN	Inch	Dash	Female coupling	Male coupling		A	B	C	D	E	F
12.5	1/2"	-08	Q00811191A-08-16	Q00211191A-08-16	M16x1,5	66.7	55.5	A+B-21,8	ø38	27	27
12.5	1/2"	-08	Q00811191A-08-18	Q00211191A-08-18	M18x1,5	68.2	57	A+B-21,8	ø38	27	27
12.5	1/2"	-08	Q00811191A-08-22	Q00211191A-08-22	M22x1,5	67	48	A+B-21,8	ø38	27	27

Q.SAFE 344

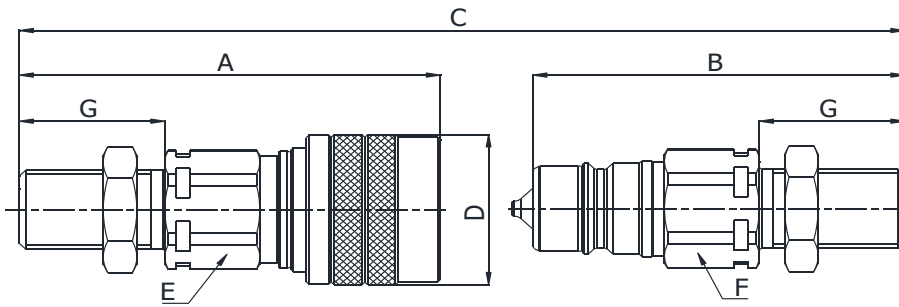

Q00811770B
Q00211770B

METRIC TERMINATION ENDS
TO ISO 8434-1
BULKHEAD L SERIES

SIZE			PART NUMBER		THREAD	DIMENSIONS mm						
DN	Inch	Dash	Female coupling	Male coupling		A	B	C	D	E	F	G
10	3/8"	-06	Q00811770B-06-12	Q00211770B-06-12	M12x1,5	76	67.5	A+B-17,5	ø30	22	22	25
10	3/8"	-06	Q00811770B-06-14	Q00211770B-06-14	M14x1,5	75	66.5	A+B-17,5	ø30	22	22	25
10	3/8"	-06	Q00811770B-06-16	Q00211770B-06-16	M16x1,5	75	66.5	A+B-17,5	ø30	22	22	26
10	3/8"	-06	Q00811770B-06-18	Q00211770B-06-18	M18x1,5	75	66.5	A+B-17,5	ø30	22	22	26
12.5	1/2"	-08	Q00811770B-08-14	Q00211770B-08-14	M14x1,5	80.2	69	A+B-21,8	ø38	27	27	25
12.5	1/2"	-08	Q00811770B-08-16	Q00211770B-08-16	M16x1,5	80.2	69	A+B-21,8	ø38	27	27	26
12.5	1/2"	-08	Q00811770B-08-18	Q00211770B-08-18	M18x1,5	80.2	69	A+B-21,8	ø38	27	27	26
12.5	1/2"	-08	Q00811770B-08-22	Q00211770B-08-22	M22x1,5	81.2	70	A+B-21,8	ø38	27	27	27
12.5	1/2"	-08	Q00811770B-08-26	Q00211770B-08-26	M26x1,5	82.2	71	A+B-21,8	ø38	30	30	28
20	3/4"	-12	Q00811770B-12-22	Q00211770B-12-22	M22x1,5	100.7	81.3	A+B-26,7	ø45	34	34	27
20	3/4"	-12	Q00811770B-12-30	Q00211770B-12-30	M30x2	105.7	86.3	A+B-26,7	ø45	34	34	32
25	1"	-16	Q00811770B-16-26	Q00211770B-16-26	M26x1,5	110.5	92.3	A+B-32,7	ø52	41	41	28
25	1"	-16	Q00811770B-16-30	Q00211770B-16-30	M30x2	114.5	96.3	A+B-32,7	ø52	41	41	32
25	1"	-16	Q00811770B-16-36	Q00211770B-16-36	M36x2	114.5	96.3	A+B-32,7	ø52	41	41	32

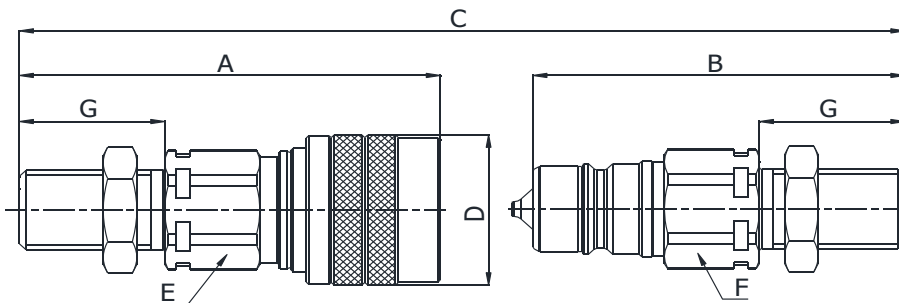

Q00811870B
Q00211870B

METRIC TERMINATION ENDS
TO ISO 8434-1
BULKHEAD S SERIES

SIZE			PART NUMBER		THREAD	DIMENSIONS mm						
DN	Inch	Dash	Female coupling	Male coupling		A	B	C	D	E	F	G
10	3/8"	-06	Q00811870B-06-16	Q00211870B-06-16	M16x1,5	76	67.5	A+B-17,5	ø30	22	22	27
10	3/8"	-06	Q00811870B-06-18	Q00211870B-06-18	M18x1,5	76	67.5	A+B-17,5	ø30	22	22	27
12.5	1/2"	-08	Q00811870B-08-18	Q00211870B-08-18	M18x1,5	81.2	70	A+B-21,8	ø38	27	27	27
12.5	1/2"	-08	Q00811870B-08-20	Q00211870B-08-20	M20x1,5	81.2	70	A+B-21,8	ø38	27	27	27
12.5	1/2"	-08	Q00811870B-08-24	Q00211870B-08-24	M24x1,5	83.2	72	A+B-21,8	ø38	27	27	29
25	1"	-16	Q00811870B-16-30	Q00211870B-16-30	M30x2	116.5	101.5	A+B-32,7	ø52	41	41	34
25	1"	-16	Q00811870B-16-36	Q00211870B-16-36	M36x2	118.5	103.5	A+B-32,7	ø52	41	41	36
25	1"	-16	Q00811870B-16-42	Q00211870B-16-42	M40x2	120.5	105.5	A+B-32,7	ø52	41	41	40

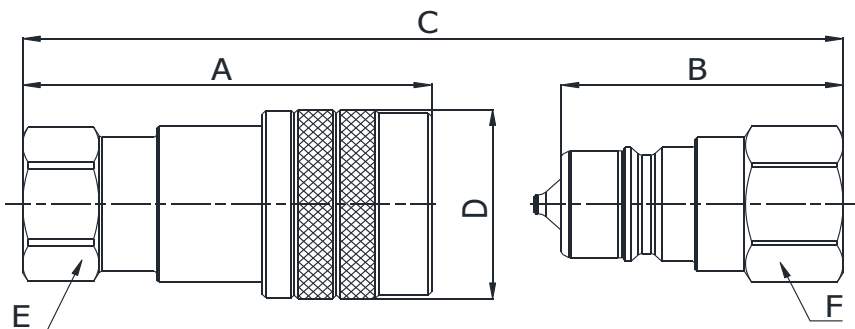

Q00811141A
Q00211141A

METRIC TERMINATION ENDS
TO ISO 3852-1 X TYPE

SIZE			PART NUMBER		THREAD	DIMENSIONS mm					
DN	Inch	Dash	Female coupling	Male coupling		A	B	C	D	E	F
10	3/8"	-06	Q00811141A-06-16	Q00211141A-06-16	M16x1,5	64.5	56	A+B-17,5	ø30	22	22
12.5	1/2"	-08	Q00811141A-08-18	Q00211141A-08-18	M18x1,5	66.2	55	A+B-21,8	ø38	27	27
12.5	1/2"	-08	Q00811141A-08-20	Q00211141A-08-20	M20x1,5	67	45	A+B-21,8	ø38	27	27
12.5	1/2"	-08	Q00811141A-08-22	Q00211141A-08-22	M22x1,5	67	48	A+B-21,8	ø38	27	27

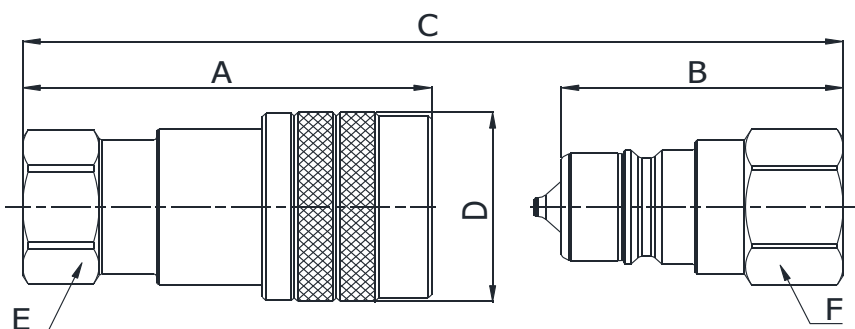

Q00811341A
Q00211341A

NPTF TERMINATION ENDS
TO ANSI B 1.20.3

SIZE			PART NUMBER		THREAD	DIMENSIONS mm					
DN	Inch	Dash	Female coupling	Male coupling		A	B	C	D	E	F
6.3	1/4"	-04	Q00811341A-04-04	Q00211341A-04-04	1/4" NPTF	48.8	34.5	A+B-14,2	ø24	17	17
10	3/8"	-06	Q00811341A-06-06	Q00211341A-06-06	3/8" NPTF	57.8	40	A+B-17,5	ø30	22	22
10	3/8"	-06	Q00811341A-06-08	Q00211341A-06-08	1/2" NPTF	60.8	45	A+B-17,5	ø30	27	27
12.5	1/2"	-08	Q00811341A-08-08	Q00211341A-08-08	1/2" NPTF	67	45	A+B-21,8	ø38	27	27
12.5	1/2"	-08	Q00811341A-08-12	Q00211341A-08-12	3/4" NPTF	70	53	A+B-22	ø38	34	34
20	3/4"	-12	Q00811341A-12-12	Q00211341A-12-12	3/4" NPTF	83.5	56.5	A+B-26,7	ø45	34	34
25	1"	-16	Q00811341A-16-16	Q00211341A-16-16	1" NPTF	97.9	64.5	A+B-32,7	ø52	41	41
31.5	1.1/4"	-20	Q00811341A-20-20	Q00211341A-20-20	1.1/4" NPTF	118.0	75.0	A+B-43	ø69	50	50
40	1.1/2"	-24	Q00811341A-24-24	Q00211341A-24-24	1.1/2" NPTF	133.0	84.0	A+B-49	ø83	60	60

Q00811250A
Q00211250A

SAE TERMINATION ENDS
TO ISO 8434-2

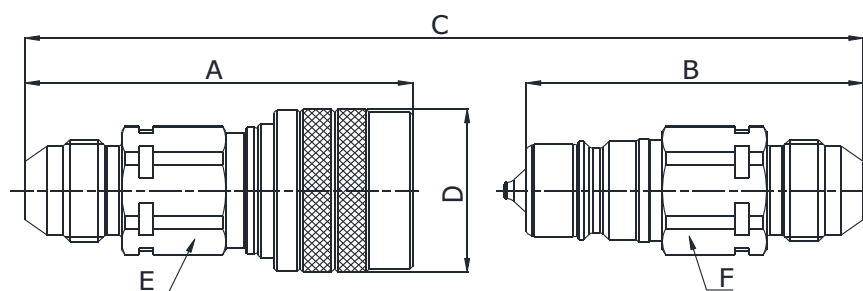

SIZE			PART NUMBER		THREAD	DIMENSIONS mm					
DN	Inch	Dash	Female coupling	Male coupling		A	B	C	D	E	F
10	3/8"	-06	Q00811250A-06-08	Q00211250A-06-08	3/4"-16 UNF	67	58.2	A+B-18,1	ø30	22	22

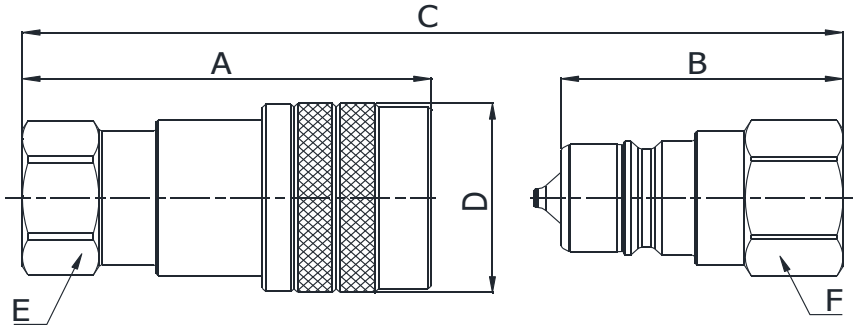

Q00811301A
Q00211301A

SAE TERMINATION ENDS
TO SAE J1926-1

SIZE			PART NUMBER		THREAD	DIMENSIONS mm					
DN	Inch	Dash	Female coupling	Male coupling		A	B	C	D	E	F
6.3	1/4"	-04	Q00811301A-04-06	Q00211301A-04-06	9/16"-18 UNF	50	34.5	A+B-14,2	ø24	17	17
10	3/8"	-06	Q00811301A-06-06	Q00211301A-06-06	9/16"-18 UNF	64.5	56	A+B-17,5	ø30	22	22
12.5	1/2"	-08	Q00811301A-08-08	Q00211301A-08-08	3/4"-16 UNF	67	45	A+B-21,8	ø38	27	27
12.5	1/2"	-08	Q00811301A-08-10	Q00211301A-08-10	7/8"-14 UNF	69	50	A+B-21,8	ø38	27	27
12.5	1/2"	-08	Q00811301A-08-12	Q00211301A-08-12	1-1/16"-12 UN	73	54	A+B-21,8	ø38	34	34

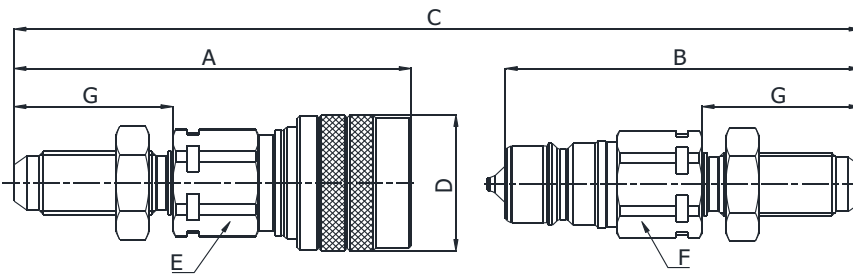

Q00811230A
Q00211230A

SAE TERMINATION ENDS
TO ISO 8434-2
BULKHEAD

SIZE			PART NUMBER		THREAD	DIMENSIONS mm						
DN	Inch	Dash	Female coupling	Male coupling		A	B	C	D	E	F	G
10	3/8"	-06	Q00811230A-06-06	Q00211230A-06-06	9/16"-18 UNF	83.8	75	A+B-18	ø30	22	22	22
10	3/8"	-06	Q00811230A-06-10	Q00211230A-06-10	7/8"-14 UNF	91.3	79.6	A+B-17,5	ø30	27	27	41
12.5	1/2"	-08	Q00811230A-08-08	Q00211230A-08-08	3/4"-16 UNF	91.8	80.6	A+B-21,8	ø38	27	27	36.6
12.5	1/2"	-08	Q00811230A-08-10	Q00211230A-08-10	7/8"-14 UNF	95.3	84.1	A+B-21,8	ø38	27	27	40.1

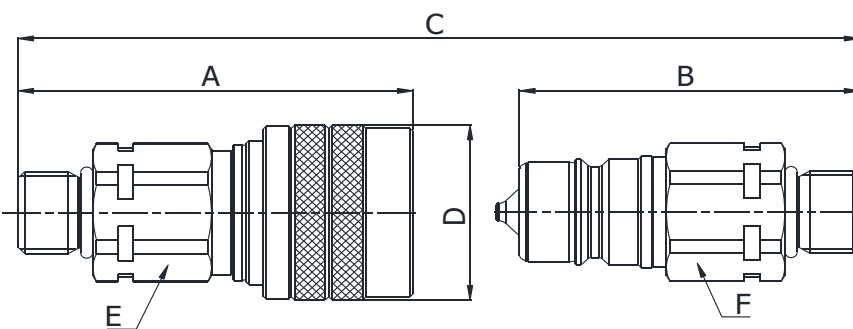

Q00811320A
Q00211320A

ORB TERMINATION ENDS
TO SAE J1926-2
S SERIES

SIZE			PART NUMBER		THREAD	DIMENSIONS mm					
DN	Inch	Dash	Female coupling	Male coupling		A	B	C	D	E	F
10	3/8"	-06	Q00811320A-06-06	Q00211320A-06-06	9/16"-18 UNF	63	54.4	A+B-17,5	ø30	22	22
12.5	1/2"	-08	Q00811320A-08-08	Q00211320A-08-08	3/4"-16 UNF	70	60	A+B-21,8	ø38	27	27

Q00811240A
Q00211240A

ORFS TERMINATION ENDS
TO ISO 8434-3

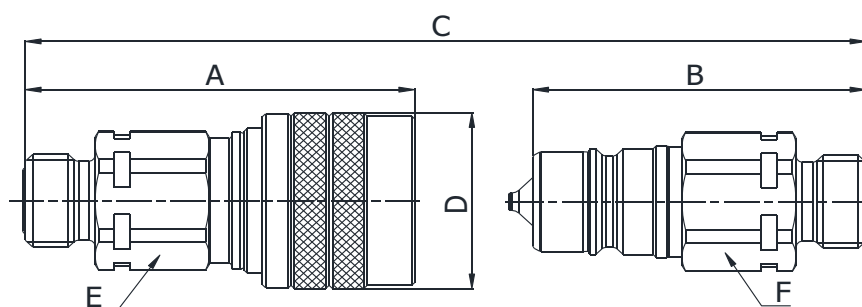

SIZE			PART NUMBER		THREAD	DIMENSIONS mm					
DN	Inch	Dash	Female coupling	Male coupling		A	B	C	D	E	F
10	3/8"	-06	Q00811240A-06-04	Q00211240A-06-04	9/16"-18 UNF	60.8	52.3	A+B-17,5	ø30	22	22
10	3/8"	-06	Q00811240A-06-06	Q00211240A-06-06	11/16"-16 UN	61.2	52.7	A+B-17,5	ø30	22	22
12.5	1/2"	-08	Q00811240A-08-08	Q00211240A-08-08	13/16"-16 UN	66.2	55.8	A+B-21,8	ø38	27	27
25	1"	-16	Q00811240A-16-16	Q00211240A-16-16	1.7/16"-12 UN	100	81.8	A+B-32,7	ø52	41	41

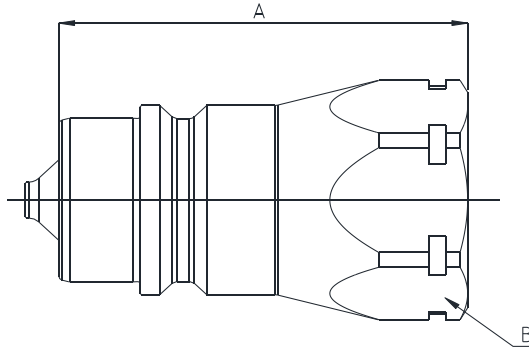

Q00411041A

BSP TERMINATION ENDS
TO DIN 3852 X TYPE

SIZE			PART NUMBER	THREAD	DIMENSIONS mm					
DN	Inch	Dash			Male coupling	A	B			
12.5	1/2"	08	Q00411041A-08-08	1/2"	47	27				

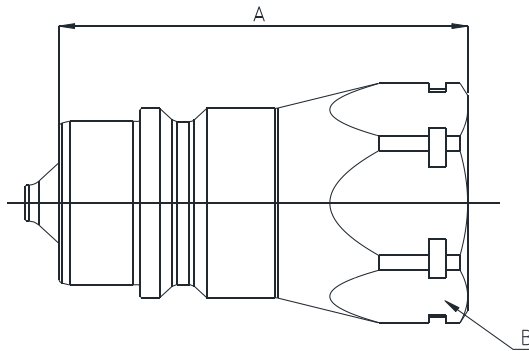

Q00411341A

NPTF TERMINATION ENDS
TO ANSI B 1.20.3

SIZE			PART NUMBER	THREAD	DIMENSIONS mm					
DN	Inch	Dash			Male coupling	A	B			
12.5	1/2"	08	Q00411341A-08-08	1/2" NPTF	47	27				

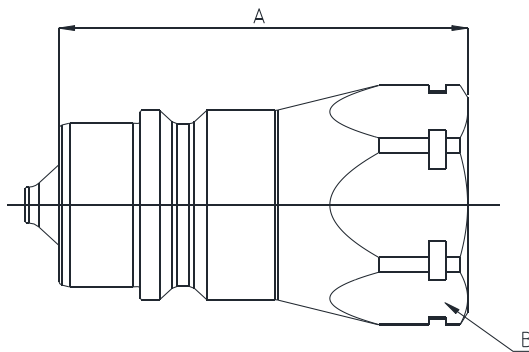

Q00411301A

SAE TERMINATION ENDS
TO SAE J1926-1

SIZE			PART NUMBER	THREAD	DIMENSIONS mm					
DN	Inch	Dash			Male coupling	A	B			
12.5	1/2"	08	Q00411301A-08-08	3/4" UNF	47	27				



ISO A BALL VALVES

Pressure Drop

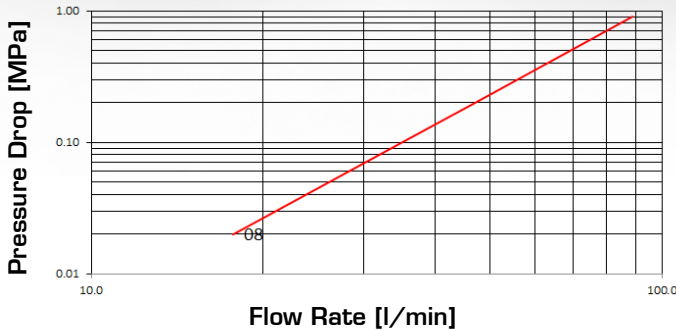

Pressure Drop

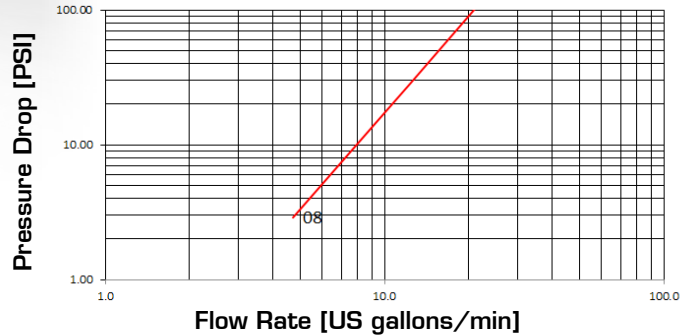

Q.SAFE 350

TECHNICAL DATA

SIZE			WORKING PRESSURE (Dynamic)		RATED FLOW at 0.2 MPa of pressure drop		CONNECTION EFFORT		OIL SPILLAGE Connection/Disconnection		MINIMUM BURST PRESSURE			CONNECTION/DISCONNECTION UNDER PRESSURE			
DN	inch	Dash	MPa	PSI	l/min	US GPM	N	lb.	cc.	cubic inch	Male		Female		M & F		
			MPa	PSI	l/min	US GPM	N	lb.	cc.	cubic inch	MPa	PSI	MPa	PSI	MPa	PSI	
12.5	½	08	21	3045	47	12.4	65	144	1.6	0.098	85	12325	100	14500	150	21750	NOT ALLOWED

The rated flow represents the normal operating condition. The maximum recommended flow rate is equal to 1.5 times the rated flow

PRODUCT DESCRIPTION

- Simple connection and disconnection by pulling back the sleeve
- Positive, quick connection of the male into the female by the latching ball system
- Shut-off by ball valve
- High resistant materials and hardened male and sleeve to withstand the brinelling effect
- Interchangeability according to ISO 7241 series A

MATERIAL

Female couplings in steel, with some hardened areas, in correspondence to the most stressed points. Male couplings in high grade carbon steel. Springs in C98 steel, seals in NBR (other materials on request) and back-up ring in PTFE

WORKING TEMPERATURE

-22°F up to +230°F (-30°C up to +110°C)
For other temperatures, the coupling may be assembled with the specific seals

SAFETY FACTOR

4:1 for dynamic pressures

IMPULSE PRESSURES

100,000 cycles at 133% of the rated one (freq. 1Hz)

TEST SPECIFICATIONS

ISO 18869

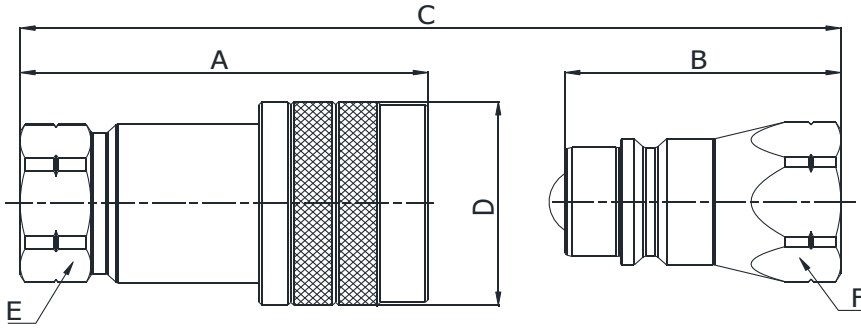

Q00911041A
Q00311041A

BSP TERMINATION ENDS
TO DIN 3852

SIZE			PART NUMBER		THREAD	DIMENSIONS mm					
DN	Inch	Dash	Female coupling	Male coupling		A	B	C	D	E	F
12.5	1/2"	-08	Q00911041A-08-08	Q00310041A-08-08	1/2"	68.2	46.2	A+B-21,8	ø38	27	27

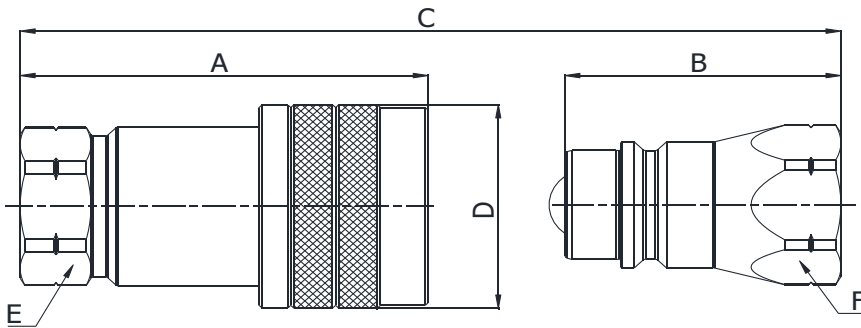

Q00911341A
Q00310341A

NFTS TERMINATION ENDS
TO ANSI B 1.20.3

SIZE			PART NUMBER		THREAD	DIMENSIONS mm					
DN	Inch	Dash	Female coupling	Male coupling		A	B	C	D	E	F
12.5	1/2"	-08	Q00911341A-08-08	Q00310341A-08-08	1/2" NPTF	68.2	46.2	A+B-21,8	ø38	27	27

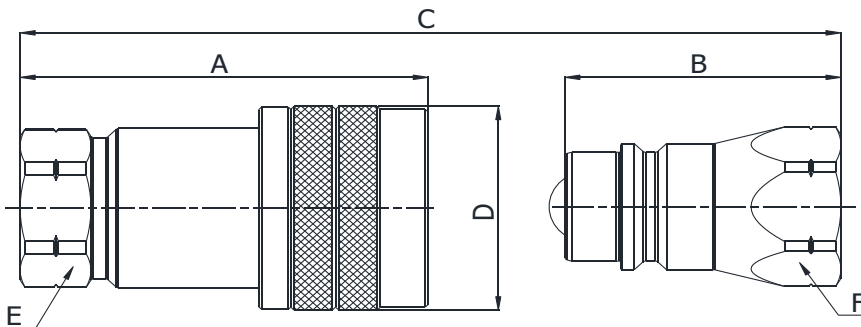

Q00911301A
Q00310301A

SAE TERMINATION ENDS
TO SAE J1926-1

SIZE			PART NUMBER		THREAD	DIMENSIONS mm					
DN	Inch	Dash	Female coupling	Male coupling		A	B	C	D	E	F
12.5	1/2"	-08	Q00911301A-08-08	Q00310301A-08-08	3/4"-16 UNF	67	45	A+B-21,8	ø38	27	27



ISO A CONNECTABLE UNDER PRESSURE

Pressure Drop

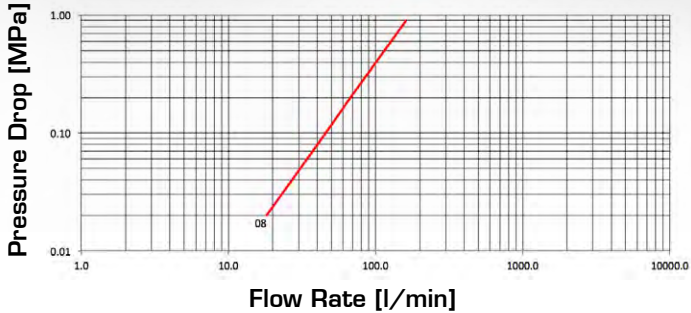

Pressure Drop

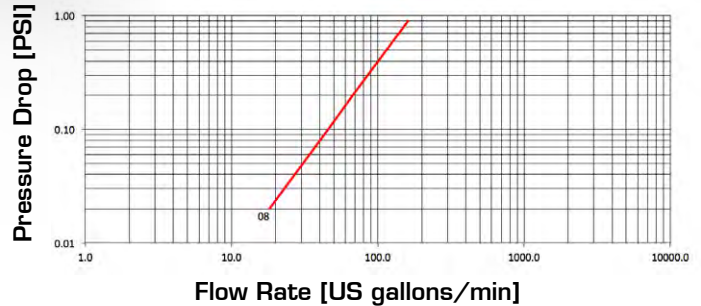

Q.SAFE 352

TECHNICAL DATA

SIZE		WORKING PRESSURE (Dynamic)		RATED FLOW at 0.2 MPa of pressure drop		CONNECTION EFFORT		OIL SPILLAGE Connection/Disconnection		MINIMUM BURST PRESSURE						CONNECTION/DISCONNECTION UNDER PRESSURE
DN	inch	MPa	PSI	l/min	US GPM	N	lb.	cc.	cubic inch	Male		Female		M & F		
										MPa	PSI	MPa	PSI	MPa	PSI	
12.5	½	08	30	4350	68	18.0	80	178	2 0.122 With 0 MPa pressure	120	17400	120	17400	160	23200	Only connection

The rated flow represents the normal operating condition. The maximum recommended flow rate is equal to 1.5 times the rated flow

PRODUCT DESCRIPTION

- Connectable under pressure thanks to a frontal micro-valve
- Connection and disconnection is possible by pulling back the sleeve
- Positive, quick connection of the male into the female by the latching ball system
- Shut-off by poppet valve
- High resistant materials
- Connectability at the maximum working pressure
- Interchangeable according to ISO 7241 series A

MATERIAL

Female couplings in steel, with some hardened areas, in correspondence to the most stressed points. Male couplings in high grade carbon steel. Springs in C98 steel, seals in NBR and polyurethane (other materials on request) and back-up ring in PTFE. PU seal on ½" female available on request.

WORKING TEMPERATURE

-22°F up to +230°F (-30°C up to +110°C)
For other temperatures, the coupling may be assembled with the specific seals

SAFETY FACTOR

4:1 for dynamic pressures

IMPULSE PRESSURES

100,000 cycles at 133% of the rated one (freq. 1Hz)

TEST SPECIFICATIONS

ISO 18869

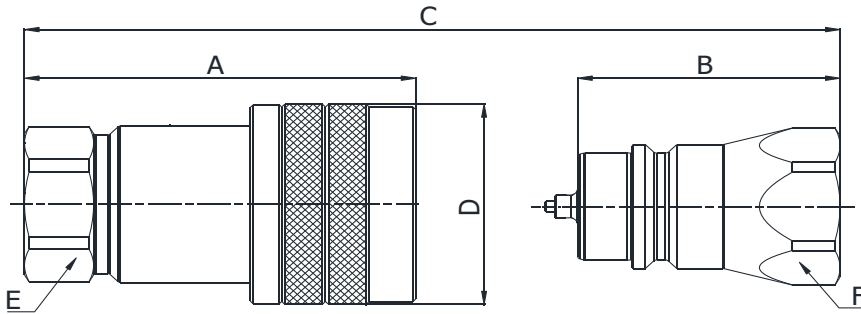

Q01011041A
Q00611041A

BSP TERMINATION ENDS
TO DIN 3852 X TYPE

SIZE			PART NUMBER		THREAD	DIMENSIONS mm					
DN	Inch	Dash	Female coupling	Male coupling		A	B	C	D	E	F
12.5	1/2"	-08	Q01011041A-08-08	Q00611041A-08-08	1/2"	67	45	A+B-21,8	ø38	27	27

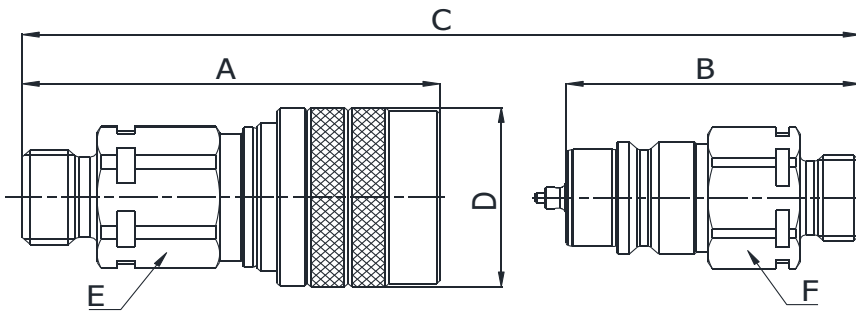

Q01011110A
Q00611110A

METRIC TERMINATION END
TO ISO 8434-1
L SERIES

SIZE			PART NUMBER		THREAD	DIMENSIONS mm					
DN	Inch	Dash	Female coupling	Male coupling		A	B	C	D	E	F
12.5	1/2"	-08	Q01011110A-08-18	Q00611110A-08-18	M18x1,5	65.2	54	A+B-21,8	ø38	27	27

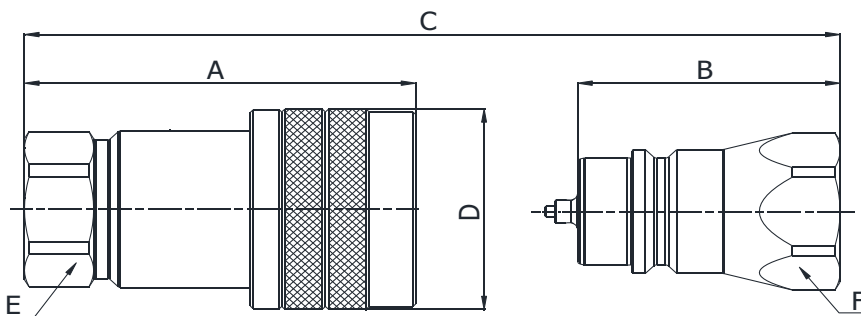

Q01011341A
Q00611341A

NPTF TERMINATION END
TO ANSI B 1.20.3

SIZE			PART NUMBER		THREAD	DIMENSIONS mm					
DN	Inch	Dash	Female coupling	Male coupling		A	B	C	D	E	F
12.5	1/2"	-08	Q01011341A-08-08	Q00611341A-08-08	1/2" NPTF	67	45	A+B-21,8	ø38	27	27

ISO A MALE CONNECTABLE UNDER PRESSURE



Pressure Drop

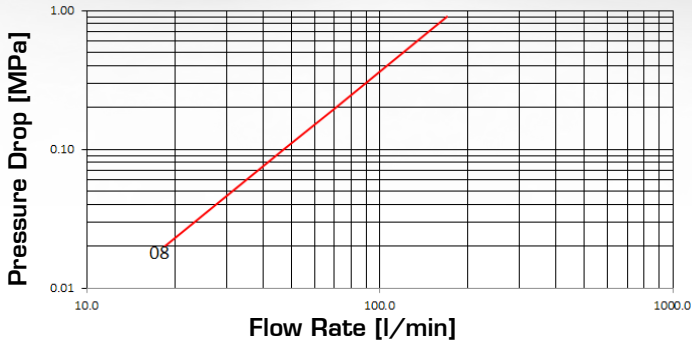

Pressure Drop

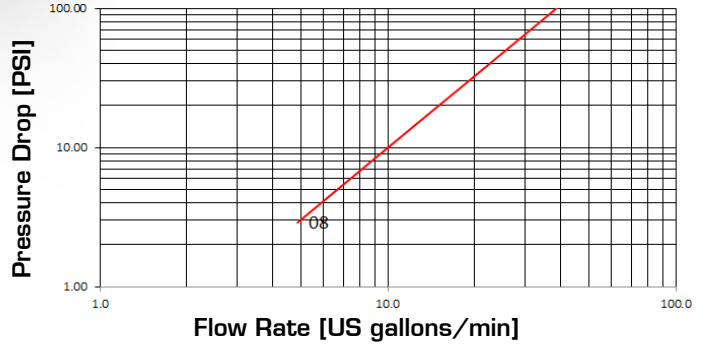

TECHNICAL DATA

SIZE			WORKING PRESSURE (Dynamic)		RATED FLOW at 0.2 MPa of pressure drop		CONNECTION EFFORT		OIL SPILLAGE Connection/Disconnection		MINIMUM BURST PRESSURE						CONNECTION/DISCONNECTION UNDER PRESSURE
DN	inch	Dash	MPa	PSI	l/min	US GPM	N	lb.	cc.	cubic inch	Male		Female		M & F		
											MPa	PSI	MPa	PSI	MPa	PSI	
12.5	½	08	30	4350	71	18.8	80	178	2	0.122	-	-	125	18125	125	18125	Connection only, with male under pressure

The rated flow represents the normal operating condition. The maximum recommended flow rate is equal to 1.5 times the rated flow

PRODUCT DESCRIPTION

- Connectable with male ISO A under pressure
- High working pressure 30MPa
- Simple connection and disconnection by pulling back the sleeve
- No shut-off, Manuli mechanical valve block system
- Installations on hoses, pipe and direct to port
- Wide range of termination ends
- Interchangeability according to ISO 7241 series A

MATERIAL

Female couplings in steel, with some hardened areas, in correspondence to the most stressed points. Carbonitrided valve, and sleeve, springs in C98 steel, seals in NBR (other materials on request) and back-up ring in PTFE. PU seal on ½" female available on request.

WORKING TEMPERATURE

-22°F up to +230°F (-30°C up to +110°C)
For other temperatures, the coupling may be assembled with the specific seals

SAFETY FACTOR

4:1 for dynamic pressures

IMPULSE PRESSURES

500,000 cycles (connected and disconnected conditions) at 120% of the rated one (freq. 1Hz)

TEST SPECIFICATIONS

ISO 18869

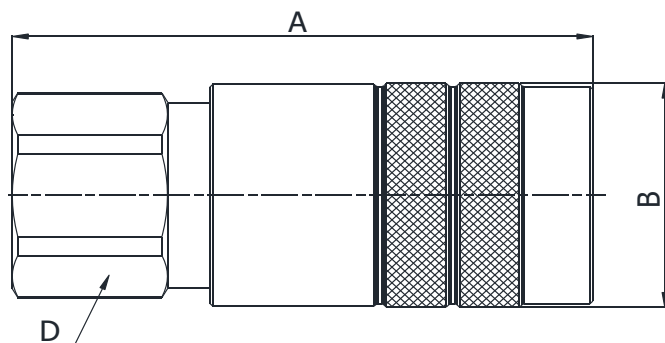

Q01111041A

BSP TERMINATION ENDS
TO DIN 3852 X TYPE

SIZE			PART NUMBER	THREAD	DIMENSIONS mm					
DN	Inch	Dash	Female coupling		A	B	D			
12.5	1/2"	-08	Q01111041A-08-08	1/2"	91.7	ø38,3	32			

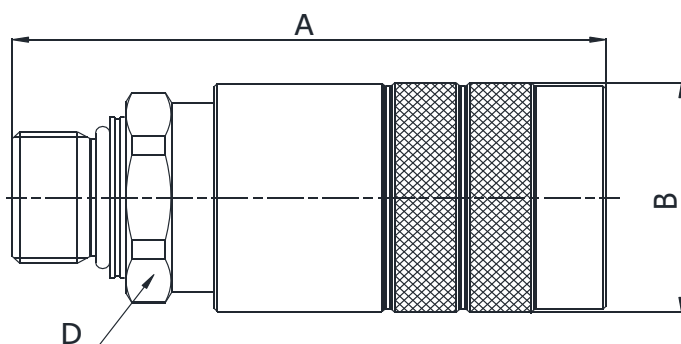

Q01111190A

METRIC TERMINATION ENDS
TO ISO 6149-1

SIZE			PART NUMBER	THREAD	DIMENSIONS mm					
DN	Inch	Dash	Female coupling		A	B	D			
12.5	1/2"	-08	Q01111190A-08-22	M22x1,5	91.2	ø38,3	32			

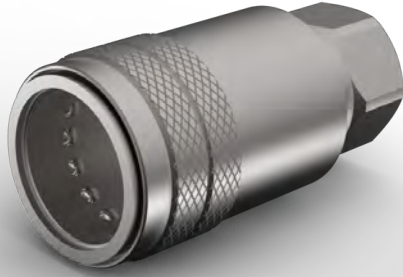

ISO A BOTH PARTS CONNECTABLE UNDER PRESSURE

Pressure Drop

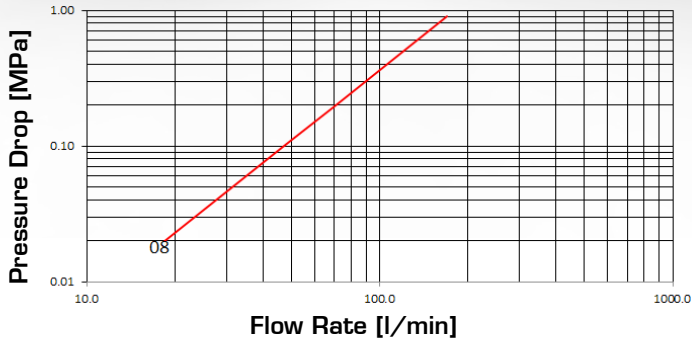

Pressure Drop

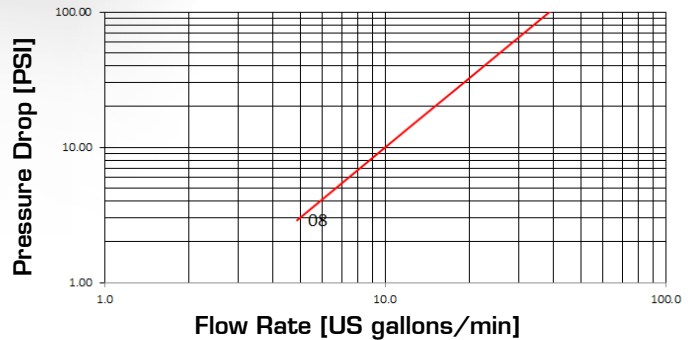

TECHNICAL DATA

SIZE			WORKING PRESSURE [Dynamic]		RATED FLOW at 0.2 MPa of pressure drop		CONNECTION EFFORT		OIL SPILLAGE Connection/Disconnection		MINIMUM BURST PRESSURE						CONNECTION/DISCONNECTION UNDER PRESSURE
DN	inch	Dash	MPa	PSI	l/min	US GPM	N	lb.	cc.	cubic inch	Male		Female		M & F		
											MPa	PSI	MPa	PSI	MPa	PSI	
12.5	½	08	30	4350	71	18.8	80	178	2	0.122	-	-	125	18125	125	18125	Connection only, with male and female under pressure

The rated flow represents the normal operating condition. The maximum recommended flow rate is equal to 1.5 times the rated flow

PRODUCT DESCRIPTION

- Connectable with male (ISO A) and female under pressure
- High working pressure 30MPa
- Simple connection and disconnection by pulling back the sleeve
- No shut-off, Manuli mechanical valve block system
- Installations on hoses, pipe and direct to port
- Wide range of termination ends
- Interchangeable according to ISO 7241 series A

MATERIAL

Female couplings in steel, with some hardened areas, in correspondence to the most stressed points. Carbonitrided valves and sleeve, springs in C98 steel, seals in NBR and polyurethane (other materials on request) and back-up ring in PTFE. PU seal on ½" female available on request.

WORKING TEMPERATURE

-22°F up to +230°F (-30°C up to +110°C)
For other temperatures, the coupling may be assembled with the specific seals

SAFETY FACTOR

4:1 for dynamic pressures

IMPULSE PRESSURES

500,000 cycles (connected and disconnected conditions) at 120% of the rated one (freq. 1Hz)

TEST SPECIFICATIONS

ISO 18869

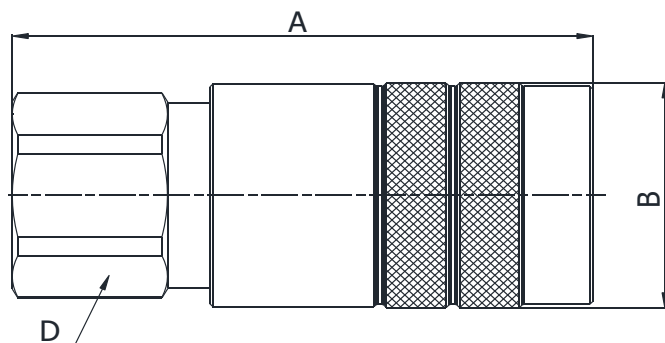

Q01211041A

BSP TERMINATION ENDS
TO DIN3852

SIZE			PART NUMBER	THREAD	DIMENSIONS mm					
DN	Inch	Dash	Female coupling		A	B	D			
12.5	1/2"	-08	Q01211041A-08-08	1/2"	93.6	ø38,3	32			

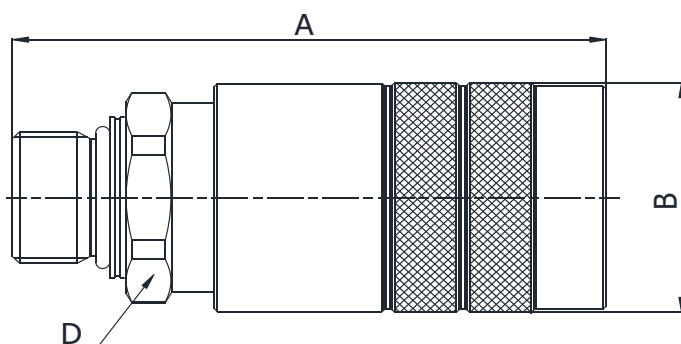

Q01211190A

METRIC TERMINATION ENDS
TO ISO 6149-2

SIZE			PART NUMBER	THREAD	DIMENSIONS mm					
DN	Inch	Dash	Female coupling		A	B	D			
12.5	1/2"	-08	Q01211190A-08-22	M22x1,5	93.1	ø38,3	32			



ISO B POPPET VALVES

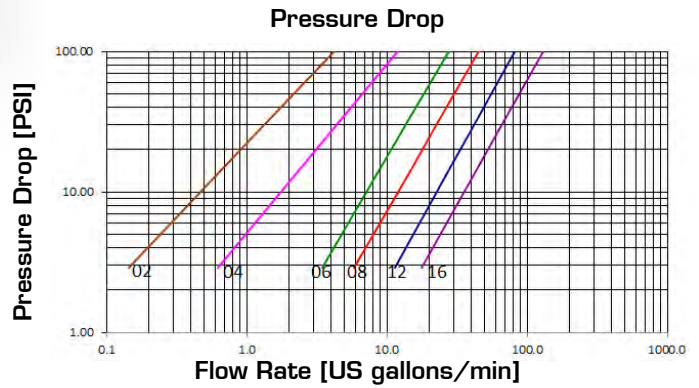
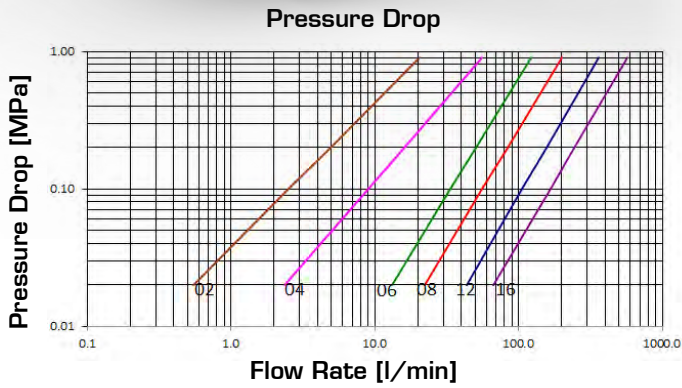

TECHNICAL DATA

SIZE			WORKING PRESSURE (Dynamic)		RATED FLOW at 0.2 MPa of pressure drop		CONNECTION EFFORT		OIL SPILLAGE Connection/Disconnection		MINIMUM BURST PRESSURE						CONNECTION/DISCONNECTION UNDER PRESSURE
DN	inch	Dash	MPa	PSI	l/min	US GPM	N	lb.	cc.	cubic inch	Male		Female		M & F		
											MPa	PSI	MPa	PSI	MPa	PSI	
5	1/8	02	50	7250	5	1.3	40	9.0	0.5	0.031	210	30450	270	39150	220	31900	Not allowed
6.3	1/4	04	40	5800	16	4.3	40	9.0	0.8	0.049	180	26100	190	27550	165	23925	Not allowed
10	3/8	06	35	5075	51	13.5	40	9.0	1.5	0.092	145	21025	160	23200	160	23200	Not allowed
12.5	1/2	08	35	5075	84	22.0	70	15.7	2.5	0.153	145	21025	145	21025	160	23200	Not allowed
20	3/4	12	25	3625	156	41.5	90	20.2	8.5	0.519	100	14500	100	14500	125	18125	Not allowed
25	1	16	25	3625	246	65.0	90	20.2	15.0	0.915	100	14500	100	14500	120	17400	Not allowed

The rated flow represents the normal operating condition. The maximum recommended flow rate is equal to 1.5 times the rated flow

PRODUCT DESCRIPTION

- Reference series for all industrial applications
- Simple connection and disconnection by pulling back the sleeve
- Positive, quick connection of the male into the female by latching the ball system
- Shut-off by poppet valve
- High resistant materials
- Interchangeable according to ISO 7241 series B

MATERIAL

Female couplings in steel, with some hardened areas, in correspondence to the most stressed points. Male couplings in high grade carbon steel hardened. Springs in C98 steel, seals in NBR (other materials on request) and back-up ring in PTFE

WORKING TEMPERATURE

-22°F up to +230°F (-30°C up to +110°C)
For other temperatures, the coupling may be assembled with the specific seals

SAFETY FACTOR

4:1 for dynamic pressures

IMPULSE PRESSURES

100,000 cycles at 133% of the rated one (freq. 1Hz)

TEST SPECIFICATIONS

ISO 18869

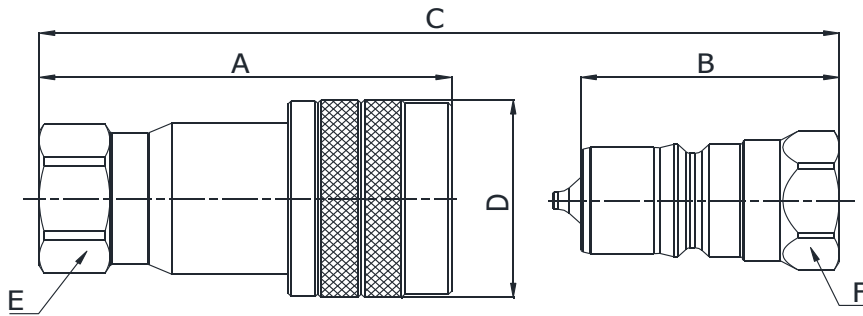

**Q02411041A
Q02111041A**

BSP TERMINATION ENDS
TO DIN 3852 X TYPE

SIZE			PART NUMBER		THREAD	DIMENSIONS mm					
DN	Inch	Dash	Female coupling	Male coupling		A	B	C	D	E	F
5	1/8"	-02	Q02411041A-02-02	Q02111041A-02-02	1/8"	48.5	30	A+B-18,7	ø22	15	14
6.3	1/4"	-04	Q02411041A-04-04	Q02111041A-04-04	1/4"	58.8	37.2	A+B-21,2	ø28	19	19
10	3/8"	-06	Q02411041A-06-06	Q02111041A-06-06	3/8"	66.2	41.5	A+B-24,4	ø35	24	22
12.5	1/2"	-08	Q02411041A-08-08	Q02111041A-08-08	1/2"	74	46.5	A+B-27,2	ø42	30	27
20	3/4"	-12	Q02411041A-12-12	Q02111041A-12-12	3/4"	91	56.5	A+B-34,2	ø52	36	36
25	1"	-16	Q02411041A-16-16	Q02111041A-16-16	1"	104	64.5	A+B-39,2	ø60	41	41

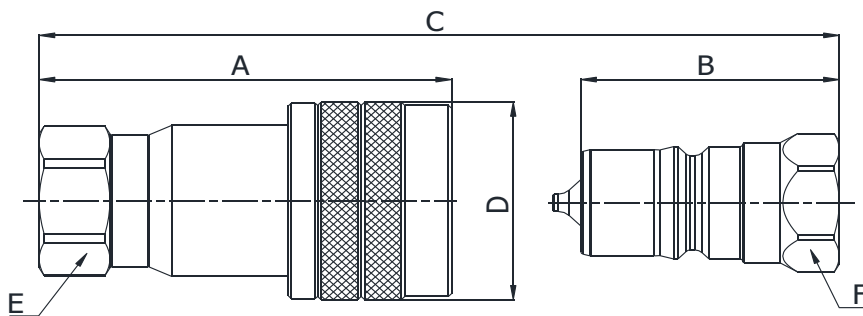

**Q02411341A
Q02111341A**

NPTF TERMINATION END
TO ANSI B 1.20.3

SIZE			PART NUMBER		THREAD	DIMENSIONS mm					
DN	Inch	Dash	Female coupling	Male coupling		A	B	C	D	E	F
5	1/8"	-02	Q02411341A-02-02	Q02111341A-02-02	1/8" NPTF	48.5	30	A+B-18,7	ø22	15	14
6.3	1/4"	-04	Q02411341A-04-04	Q02111341A-04-04	1/4" NPTF	58.8	37.2	A+B-21,2	ø28	19	19
10	3/8"	-06	Q02411341A-06-06	Q02111341A-06-06	3/8" NPTF	66.2	41.5	A+B-24,4	ø35	24	22
12.5	1/2"	-08	Q02411341A-08-08	Q02111341A-08-08	1/2" NPTF	74	46.5	A+B-27,2	ø42	30	27
20	3/4"	-12	Q02411341A-12-12	Q02111341A-12-12	3/4" NPTF	91	56.5	A+B-34,2	ø52	36	36
25	1"	-16	Q02411341A-16-16	Q02111341A-16-16	1" NPTF	104	64.5	A+B-39,2	ø60	41	41

359 Q.SAFE

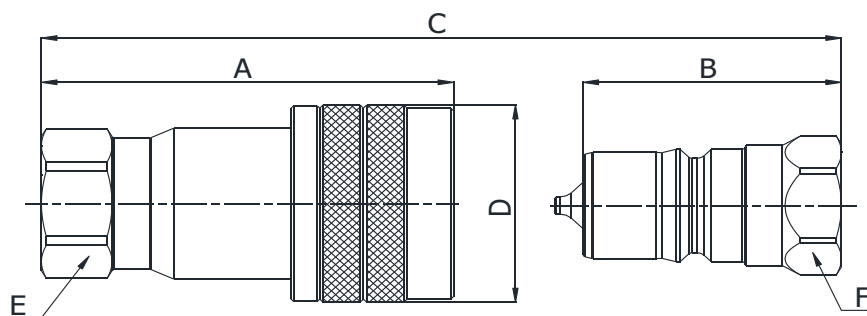

Q02411301A
Q02111301A

SAE TERMINATION ENDS
TO SAE J1926-1

SIZE			PART NUMBER		THREAD	DIMENSIONS mm					
DN	Inch	Dash	Female coupling	Male coupling		A	B	C	D	E	F
6.3	1/4"	-04	Q02411301A-04-06	Q02111301A-04-06	9/16"-18UNF	62.2	40.6	A+B-21,2	ø28	19	19
10	3/8"	-06	Q02411301A-06-08	Q02111301A-06-08	3/4"-16 UNF	68.2	46	A+B-24,4	ø35	24	24
12.5	1/2"	-08	Q02411301A-08-08	Q02111301A-08-08	3/4"-16 UNF	74	46.5	A+B-27,2	ø42	30	27
20	3/4"	-12	Q02411301A-12-12	Q02111301A-12-12	1"1/16-12 UN	94	59.5	A+B-34,2	ø52	36	34
25	1"	-16	Q02411301A-16-16	Q02111301A-16-16	1"5/16-12 UN	104	64.5	A+B-39,2	ø60	41	41



ISO B FOR DRILLING BOP UNITS

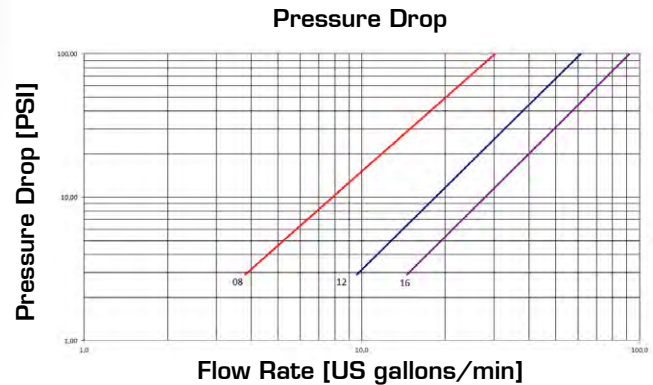
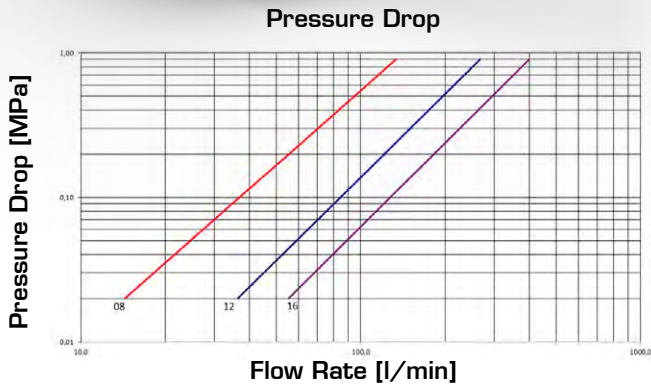

TECHNICAL DATA

SIZE			MPa		PSI		RATED FLOW at 0.2 MPa of pressure drop		CONNECTION EFFORT		OIL SPILLAGE Connection/Disconnection		MINIMUM BURST PRESSURE						CONNECTION/DISCONNECTION UNDER PRESSURE
DN	inch	Dash	MPa	PSI	MPa	PSI	l/min	US GPM	N	lb.	cc.	cubic inch	Male		Female		M & F		
			MPa	PSI	MPa	PSI							MPa	PSI	MPa	PSI	MPa	PSI	
12.5	1/2	08	42	6090	35	5075	55	14.6	70	156	2.5	0.153	140	20300	140	20300	180	26100	Not allowed
20	3/4	12	35	5075	25	3625	122	32.1	90	200	8.5	0.519	100	14500	100	14500	150	21750	Not allowed
25	1	16	35	5075	25	3625	183	48.3	90	200	15	0.916	100	14500	100	14500	140	20300	Not allowed

The rated flow represents the normal operating condition. The maximum recommended flow rate is equal to 1.5 times the rated flow

PRODUCT DESCRIPTION

- MQS-B BOP VERSION is designed for BOP (Blow-out preventer) service in Oil & Gas Industry
- Simple connection & disconnection by pulling back the sleeve
- Safety system on the female part to avoid accidental disconnection
- Positive quick connection of the male into the female by latching ball system
- Poppet valve sealing system that guarantee high sealing performance at low & high pressure
- ECOAT zinc plating with improved corrosion protection and environmentally friendly process
- Female & Male Coupling with red identification for an easy visual verification
- ISO 7241 series B interchangeable
- API 16D approval.

MATERIAL

Female & male couplings in high grade carbon steel with hardened areas in correspondence to the most stressed points. Seal in Viton with back-up in PTFE.

WORKING TEMPERATURE

-25°C to +200°C

SAFETY FACTOR

4:1 in CONNECTED & DISCONNECTED conditions

IMPULSE PRESSURES

100,000 cycles at 133% of the rated one (freq. 1Hz)

TEST SPECIFICATIONS

ISO 18869 , Flame resistance test to API 16D

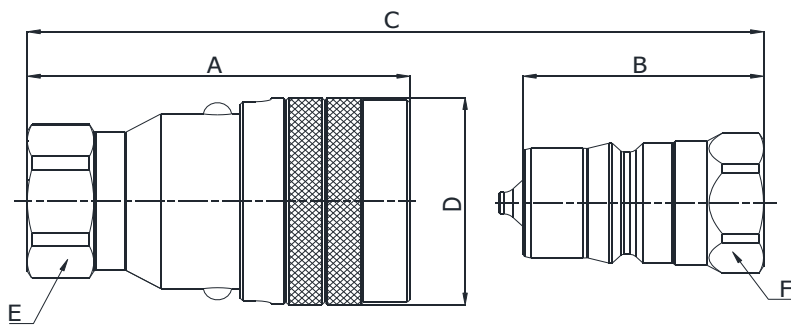

Q02613341F
Q02113341F

NPTF TERMINATION ENDS
TO ANSI B1.20.3

SIZE			PART NUMBER		THREAD	DIMENSIONS mm					
DN	Inch	Dash	Female coupling	Male coupling		A	B	C	D	E	F
12.5	1/2"	-08	Q02613341F-08-08	Q02113341F-08-08	1/2" NPTF	74	46.5	A+B-27,2	ø44	30	27
20	3/4"	-12	Q02613341F-12-12	Q02113341F-12-12	3/4" NPTF	91	56.5	A+B-34,2	ø54	36	34
25	1"	-16	Q02613341F-16-16	Q02113341F-16-16	1" NPTF	104	64.5	A+B-39,2	ø64	46	41

STANDARD POPPET VALVES

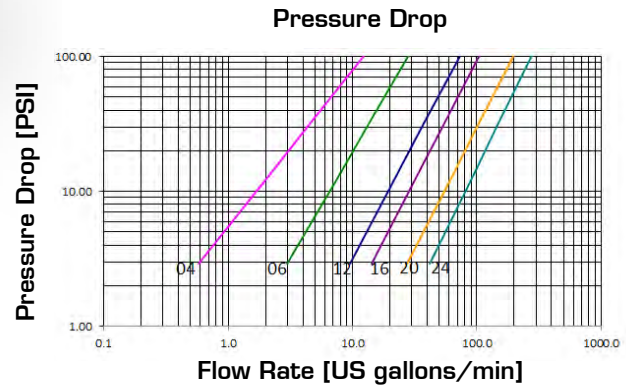
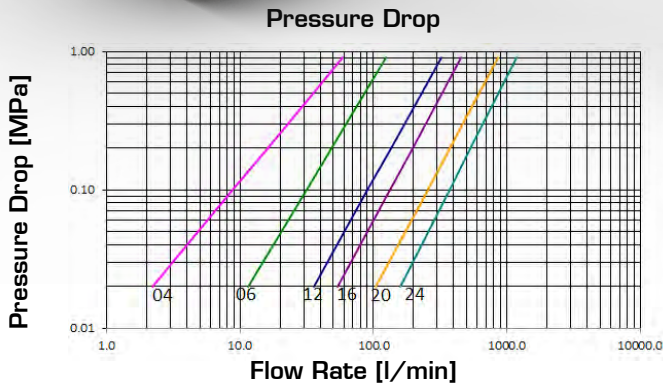

TECHNICAL DATA

SIZE			MPa		FLOW RATE		N		OIL SPILLAGE		MINIMUM BURST PRESSURE						CONNECTION / DISCONNECTION UNDER PRESSURE	
DN	inch	Dash	MPa	PSI	l/min	US GPM	N	lb.	cc.	cubic inch	Male		Female		M & F			
			MPa	PSI							MPa	PSI	MPa	PSI	MPa	PSI		
6.3	1/4	04	35	5075	16	4.2	40	89	0.8	0.049	190	27550	190	27550	140	20300	Not allowed	
10	3/8	06	35	5075	49	12.9	65	144	1.3	0.079	150	21750	160	23200	160	23200	Not allowed	
12.5	1/2	08	See ISO A Series															
20	3/4	12	25	3625	135	35.7	80	178	7	0.427	110	15950	100	14500	120	17400	Not allowed	
25	1	16	25	3625	196	51.8	90	200	11	0.672	100	14500	110	15950	120	17400	Not allowed	
31.5	1 1/4	20	22	3190	376	99.3	105	233	15	0.916	90	13050	90	13050	100	14500	Not allowed	
40	1 1/2	24	21	3045	536	141.6	115	256	24	1.465	85	12325	90	13050	100	14500	Not allowed	

The rated flow represents the normal operating condition. The maximum recommended flow rate is equal to 1.5 times the rated flow

PRODUCT DESCRIPTION

- Historical series for the agriculture market
- Simple connection and disconnection by pulling back the sleeve
- Positive, quick connection of the male into the female by latching the ball system
- Shut-off by poppet valve
- High resistant materials
- Interchangeable with similar products available on the market (1/2" size according to ISO 7241-1 series A)

MATERIAL

Female couplings in steel, with some hardened areas, in correspondence to the most stressed points. Male couplings in high grade carbon steel hardened. Springs in C98 steel, seals in NBR (other materials on request) and back-up ring in PTFE

WORKING TEMPERATURE

-22°F up to +230°F (-30°C up to +110°C)
For other temperatures, the coupling may be assembled with the specific seals

SAFETY FACTOR

4:1 for dynamic pressures

IMPULSE PRESSURES

100,000 cycles at 133% of the rated one (freq. 1Hz)

TEST SPECIFICATIONS

ISO 18869

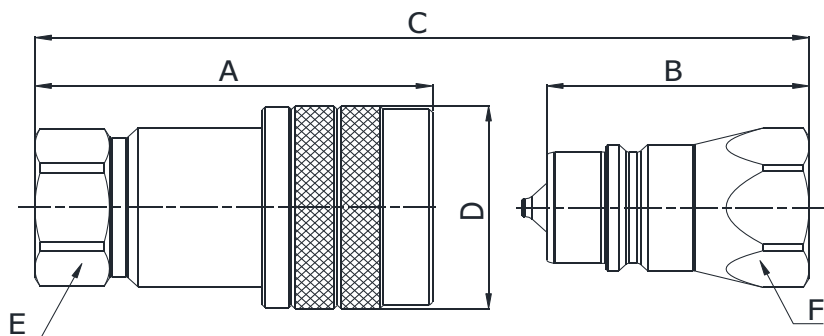

Q03211041A
Q02911041A

BSP TERMINATION ENDS
TO DIN 3852 X TYPE

SIZE			PART NUMBER		THREAD	DIMENSIONS mm					
DN	Inch	Dash	Female coupling	Male coupling		A	B	C	D	E	F
6.3	1/4"	-04	Q03211041A-04-04	Q02911041A-04-04	1/4"	53.5	36.5	A+B-16,6	ø27	19	19
10	3/8"	-06	Q03211041A-06-06	Q02911041A-06-06	3/8"	60.5	40	A+B-20,1	ø34	24	24
12.5	1/2"	-08	SEE ISO SERIES A								
20	3/4"	-12	Q03211041A-12-12	Q02911041A-12-12	3/4"	85.5	56.5	A+B-28,3	ø47	34	34
25	1"	-16	Q03211041A-16-16	Q02911041A-16-16	1"	98	64.5	A+B-32,9	ø52	41	41
31.5	1.1/4"	-20	Q03211041A-20-20	Q02911041A-20-20	1.1/4"	119.5	78	A+B-41,5	ø68	50	50
40	1.1/2"	-24	Q03211041A-24-24	Q02911041A-24-24	1.2/2"	132	88	A+B-44,2	ø80	60	60

Q.SAFE 364

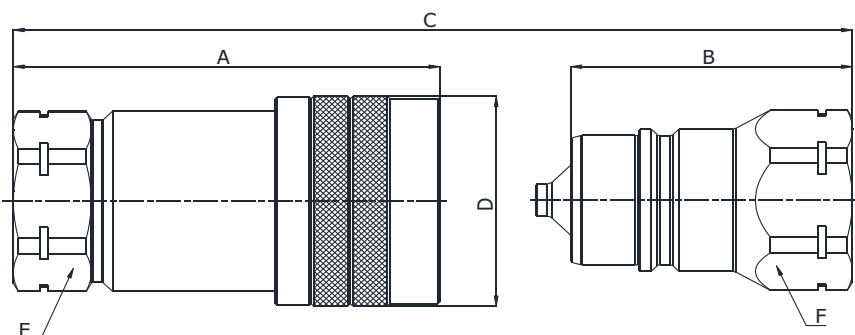

Q03211041B
Q02911041B

BSP TERMINATION ENDS
TO DIN 3852 X TYPE

SIZE			PART NUMBER		THREAD	DIMENSIONS mm					
DN	Inch	Dash	Female coupling	Male coupling		A	B	C	D	E	F
20	3/4"	-12	Q03211041B-12-12	Q02911041B-12-12	3/4"	88	56.5	A+B-31	ø47	34	34
25	1"	-16	Q03211041B-16-16	Q02911041B-16-16	1"	98	64.5	A+B-32,9	ø52	41	41

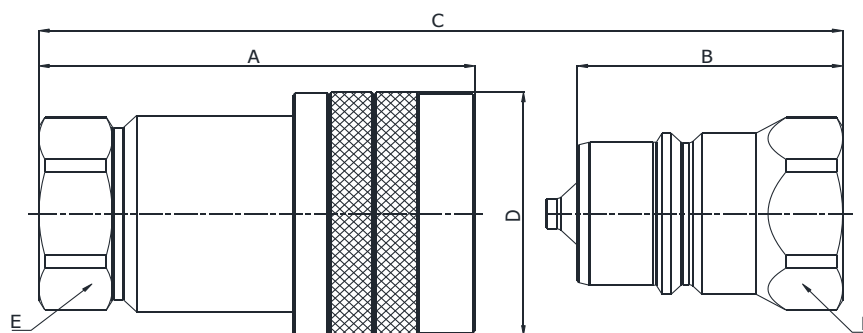

Q03211041C
Q02911041C

BSP TERMINATION ENDS
TO DIN 3852 X TYPE

SIZE			PART NUMBER		THREAD	DIMENSIONS mm					
DN	Inch	Dash	Female coupling	Male coupling		A	B	C	D	E	F
25	1"	-16	Q03211041C-16-16	Q02911041C-16-16	1"	106	64.5	A+B-40,9	ø64,3	46	46

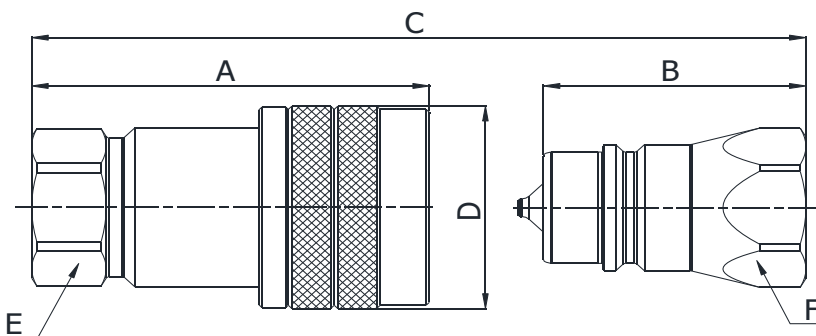

Q03211341A
Q02911341A

NPTF TERMINATION END
TO ANSI B 1.20.3

SIZE			PART NUMBER		THREAD	DIMENSIONS mm						
DN	Inch	Dash	Female coupling	Male coupling		A	B	C	D	E	F	
6.3	1/4"	-04	Q03211341A-04-04	Q02911341A-04-04	1/4" NPTF	53.5	36.5	A+B-16,6	ø27	19	19	
10	3/8"	-06	Q03211341A-06-06	Q02911341A-06-06	3/8" NPTF	60.5	40	A+B-20,1	ø34	24	24	
12.5	1/2"	-08	SEE ISO SERIES A									
20	3/4"	-12	Q03211341A-12-12	Q02911341A-12-12	3/4" NPTF	85.5	56.5	A+B-28,3	ø47	34	34	
25	1"	-16	Q03211341A-16-16	Q02911341A-16-16	1" NPTF	98	64.5	A+B-32,9	ø52	41	41	
31.5	1.1/4"	-20	Q03211341A-20-20	Q02911341A-20-20	1.1/4"	119.5	78	A+B-41,5	ø68	50	50	
40	1.1/2"	-24	Q03211341A-24-24	Q02911341A-24-24	1.2/2"	132	88	A+B-44,2	ø80	60	60	

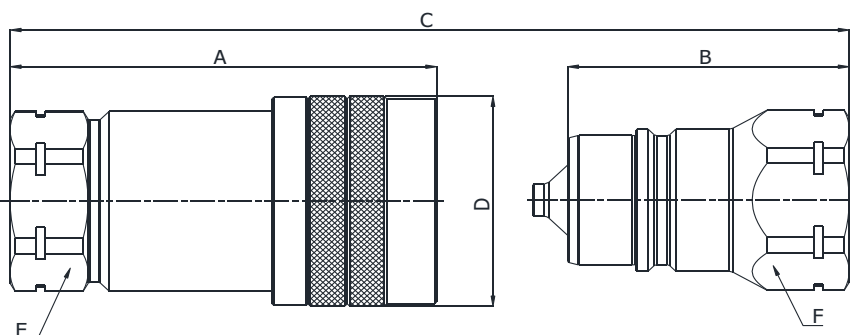

Q03211341B
Q02911341B

NPTF TERMINATION END
TO ANSI B 1.20.3

SIZE			PART NUMBER		THREAD	DIMENSIONS mm					
DN	Inch	Dash	Female coupling	Male coupling		A	B	C	D	E	F
20	3/4"	-12	Q03211341B-12-12	Q02911341B-12-12	3/4" NPTF	88	56.5	A+B-31	ø47	34	34
25	1"	-16	Q03211341B-16-16	Q02911341B-16-16	1" NPTF	98	64.5	A+B-32,9	ø52	41	41



STANDARD BALL VALVES

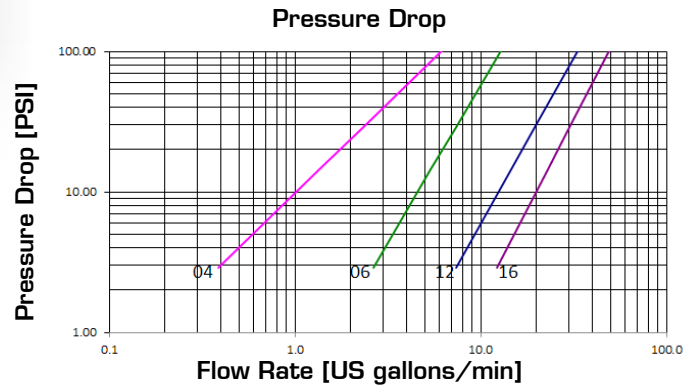
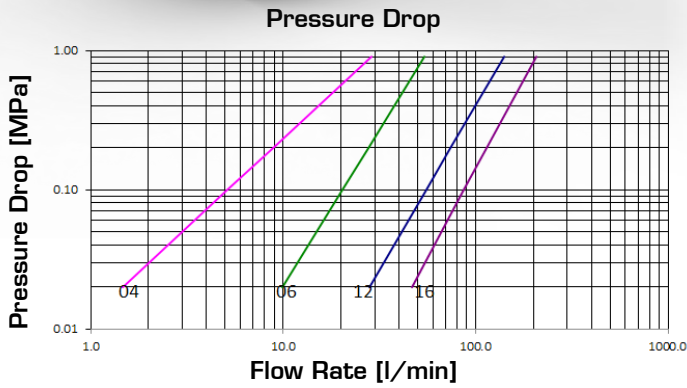

Q.SAFE 366

TECHNICAL DATA

SIZE		WORKING PRESSURE (Dynamic)		RATED FLOW at 0.2 MPa of pressure drop		CONNECTION EFFORT		OIL SPILLAGE Connection/Disconnection		MINIMUM BURST PRESSURE						CONNECTION/DISCONNECTION UNDER PRESSURE	
DN	inch	MPa	PSI	l/min	US GPM	N	lb.	cc.	cubic inch	Male		Female		M & F			
										MPa	PSI	MPa	PSI	MPa	PSI		
6.3	1/4	04	30	4350	9	2.4	40	89	0.35	0.021	140	20300	125	18125	150	21750	Not allowed
10	3/8	06	25	3625	28	7.4	65	144	0.85	0.052	115	16675	120	17400	160	23200	Not allowed
12.5	1/2	08	See ISO A Series sealed ball														
20	3/4	12	25	3625	74	19.6	75	167	3.5	0.214	100	14500	110	15950	125	18125	Not allowed
25	1	16	21	3045	114	30.1	100	222	5	0.305	85	12325	100	14500	110	15950	Not allowed

The rated flow represents the normal operating condition. The maximum recommended flow rate is equal to 1.5 times the rated flow

PRODUCT DESCRIPTION

- Historical series for the agriculture market
- Simple connection and disconnection by pulling back the sleeve
- Positive, quick connection of the male into the female by latching the ball system
- Shut-off by ball valve
- High resistant materials
- Interchangeable with poppet valve standard series and with similar products available on the market (1/2" size according to ISO 7241-1 series A)

MATERIAL

Female couplings in steel, with some hardened areas, in correspondence to the most stressed points. Male couplings in high grade carbon steel hardened. High-resistance latching balls, springs in C98 steel, seals in NBR and back-up ring in PTFE

WORKING TEMPERATURE

-22°F up to +230°F (-30°C up to +110°C)
For other temperatures, the coupling may be assembled with the specific seals

SAFETY FACTOR

4:1 for dynamic pressures

IMPULSE PRESSURES

100,000 cycles at 133% of the rated one (freq. 1Hz)

TEST SPECIFICATIONS

ISO 18869

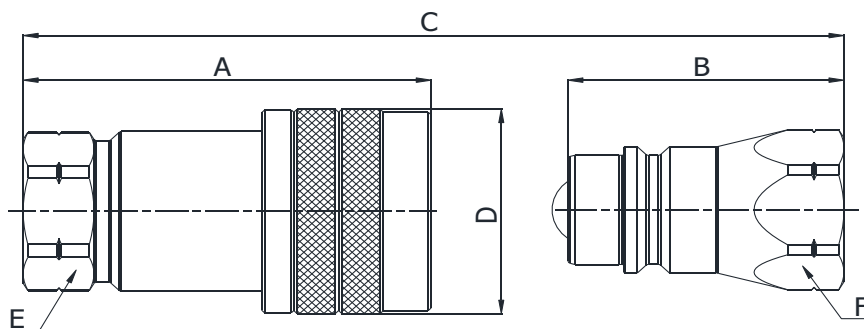

Q03311041A
Q03011041A

BSP TERMINATION ENDS
TO DIN 3852 X TYPE

SIZE			PART NUMBER		THREAD	DIMENSIONS mm						
DN	Inch	Dash	Female coupling	Male coupling		A	B	C	D	E	F	
6.3	1/4"	-04	Q03311041A-04-04	Q03010041A-04-04	1/4"	51.3	34.3	A+B-16,6	ø27	19	19	
10	3/8"	-06	Q03311041A-06-06	Q03010041A-06-06	3/8"	59.9	39.4	A+B-20,1	ø34	24	24	
12.5	1/2"	-08	SEE ISO SERIES A									
20	3/4"	-12	Q03311041A-12-12	Q03010041A-12-12	3/4"	85.5	56.5	A+B-28,3	ø47	34	34	
25	1"	-16	Q03311041A-16-16	Q03010041A-16-16	1"	98	64.5	A+B-32,9	ø52	41	41	

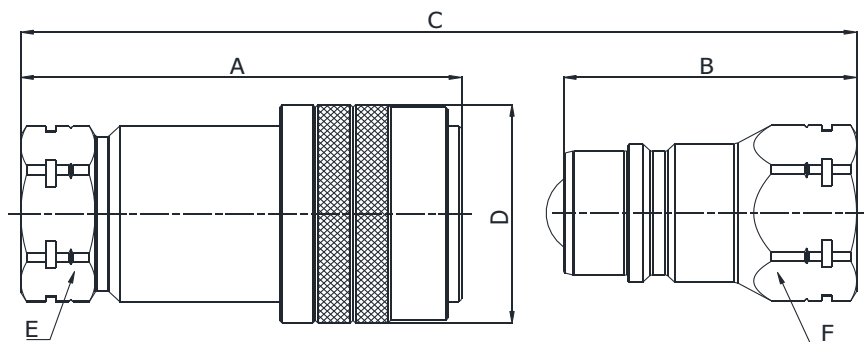

Q03311041B
Q03011041B

BSP TERMINATION ENDS
TO DIN 3852 X TYPE

SIZE			PART NUMBER		THREAD	DIMENSIONS mm					
DN	Inch	Dash	Female coupling	Male coupling		A	B	C	D	E	F
20	3/4"	-12	Q03311041B-12-12	Q03010041B-12-12	3/4"	88	58.5	A+B-31,5	ø47	34	34

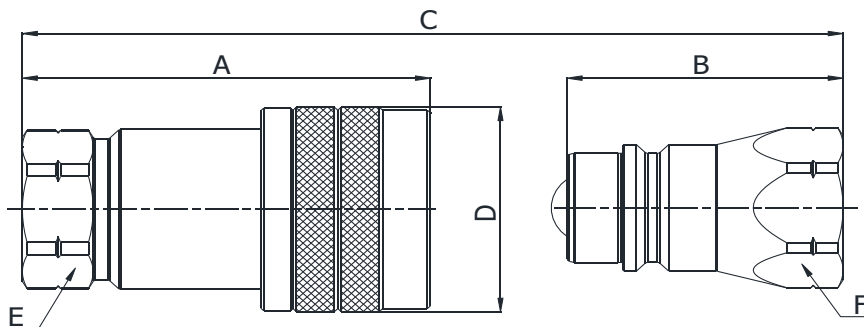

Q03311341A
Q03011341A

NPTF TERMINATION END
TO ANSI B 1.20.3

SIZE			PART NUMBER		THREAD	DIMENSIONS mm					
DN	Inch	Dash	Female coupling	Male coupling		A	B	C	D	E	F
6.3	1/4"	-04	Q03311341A-04-04	Q03010341A-04-04	1/4" NPTF	51.3	34.3	A+B-16,6	ø27	19	19
10	3/8"	-06	Q03311341A-06-06	Q03010341A-06-06	3/8" NPTF	59.9	39.4	A+B-20,1	ø34	24	24
12.5	1/2"	-08	SEE ISO SERIES A								
20	3/4"	-12	Q03311341A-12-12	Q03010341A-12-12	3/4" NPTF	85.5	56.5	A+B-28,3	ø47	34	34
25	1"	-16	Q03311341A-16-16	Q03010341A-16-16	1" NPTF	98	64.5	A+B-32,9	ø52	41	41

Q.SAFE
368

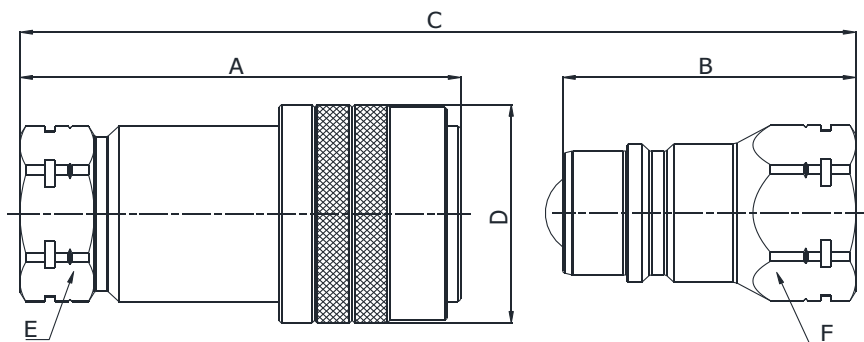

Q03311341B
Q03011341B

NPTF TERMINATION END
TO ANSI B 1.20.3

SIZE			PART NUMBER		THREAD	DIMENSIONS mm					
DN	Inch	Dash	Female coupling	Male coupling		A	B	C	D	E	F
6.3	1/4"	-04	Q03311341B-12-12	Q03010341B-12-12	3/4" NPTF	88	58.5	A+B-31,5	ø47	34	34



STANDARD FREE-FLOW

TECHNICAL DATA

SIZE			WORKING PRESSURE (Dynamic)		MINIMUM BURST PRESSURE		CONNECTION / DISCONNECTION UNDER PRESSURE
DN	inch	Dash	MPa	PSI	M & F		
					MPa	PSI	
6.3	1/4	04	35	5075	160	23200	Not allowed
10	3/8	06	35	5075	145	21025	Not allowed
12.5	1/2	08	35	5075	145	21025	Not allowed

PRODUCT DESCRIPTION

- MQS-NL is Compact Free-Flow quick release couplings
- Simple connection & disconnection by pulling back the sleeve
- Positive quick connection of the male into the female by latching ball system
- ECOAT zinc plating with improved corrosion protection and environmentally friendly process

MATERIAL

Female & male couplings in high grade carbon steel with hardened areas in correspondence to the most stressed points. Seal in NBR with back-up in PTFE.

WORKING TEMPERATURE

-30°C to +110°C

SAFETY FACTOR

4:1 in CONNECTED & DISCONNECTED conditions

IMPULSE PRESSURES

100,000 cycles at 133% of the rated one (freq. 1Hz)

TEST SPECIFICATIONS

ISO 18869

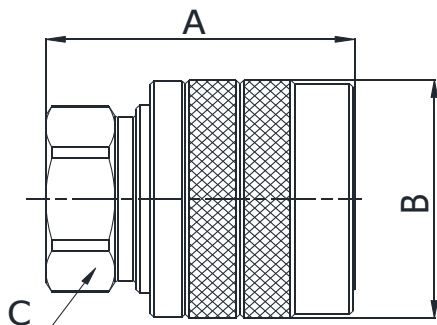

Q03811041A

BSP TERMINATION ENDS
TO DIN 3852 X TYPE

SIZE			PART NUMBER	THREAD	DIMENSIONS mm					
DN	Inch	Dash	Female coupling		A	B	C			
6.3	1/4"	-04	Q03811041A-04-04	1/4"	33.2	27.5	19			
10	3/8"	-06	Q03811041A-06-06	3/8"	39.5	34.3	24			
12.5	1/2"	-08	Q03811041A-08-08	1/2"	44	38.3	27			

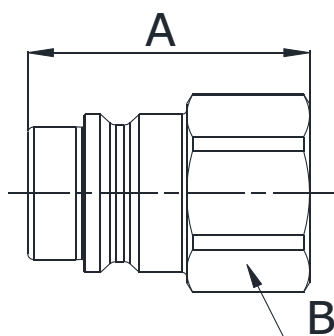

Q03711041A

BSP TERMINATION ENDS
TO DIN 3852 X TYPE

SIZE			PART NUMBER	THREAD	DIMENSIONS mm					
DN	Inch	Dash	Male coupling		A	B				
6.3	1/4"	-04	Q03710041A-04-04	1/4"	27.5	19				
10	3/8"	-06	Q03710041A-06-06	3/8"	29	24				
12.5	1/2"	-08	Q03710041A-08-08	1/2"	34	27				

STANDARD PUSH-PULL

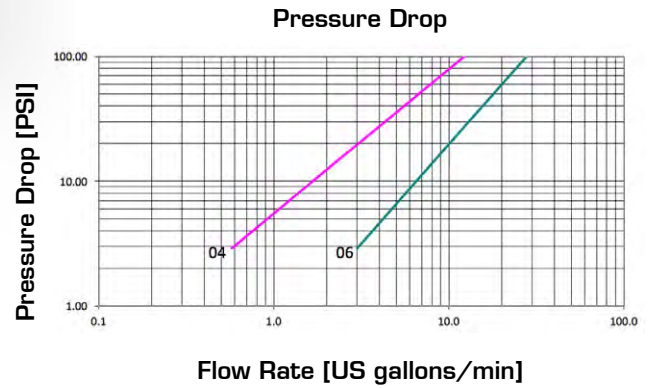
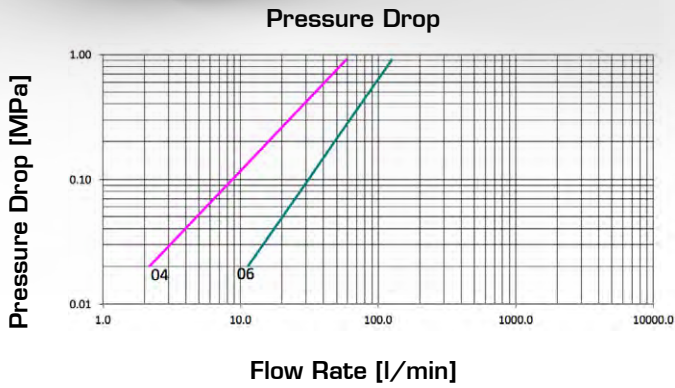

TECHNICAL DATA

SIZE		WORKING PRESSURE [Dynamic]		RATED FLOW at 0.2 MPa of pressure drop		CONNECTION EFFORT		OIL SPILLAGE Connection/ Disconnection		MINIMUM BURST PRESSURE				CONNECTION/ DISCONNECTION UNDER PRESSURE		
DN	inch	Dash	MPa	PSI	l/min	US GPM	N	lb.	cc.	cubic inch	Male		M & F			
												MPa	PSI	MPa	PSI	
6.3	1/4	04	35	5075	16	4.2	65	144	0.8	0.049	230	33350	140	20300	Not allowed	
10	3/8	06	35	5075	49	12.9	100	222	1.3	0.079	170	24650	150	21750	Not allowed	
12.5	1/2	08	See ISO A Series													

The rated flow represents the normal operating condition. The maximum recommended flow rate is equal to 1.5 times the rated flow

PRODUCT DESCRIPTION

- Female couplings designed for Agriculture applications, interchangeable with male part MQS-N
- Push-Pull connection/disconnection
- Break-away function according to ISO 5675 (in case of bulkhead mounting on the external sleeve)
- Positive connection by latching ball system
- Shut-off by poppet valve

MATERIAL

Female & male couplings in high grade carbon steel with hardened areas in correspondence to the most stressed points. Seal in NBR with back-up in PTFE.

WORKING TEMPERATURE

-30°C to +110°C

SAFETY FACTOR

4:1 in CONNECTED & DISCONNECTED conditions

IMPULSE PRESSURES

100,000 cycles at 133% of the rated one (freq. 1Hz)

TEST SPECIFICATIONS

ISO 18869

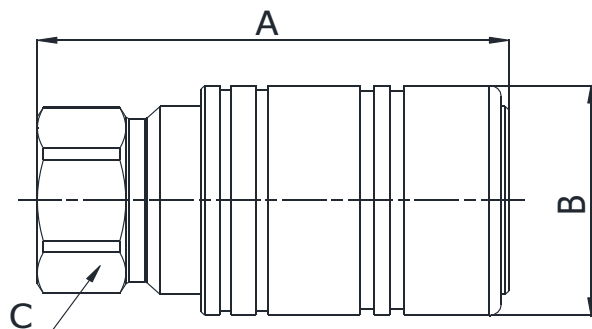

Q03611041A

BSP TERMINATION ENDS
TO DIN 3852 X TYPE

SIZE			PART NUMBER	THREAD	DIMENSIONS mm					
DN	Inch	Dash	Female coupling		A	B	C			
6.3	1/4"	-04	Q03611041A-04-04	1/4"	53.5	ø27	19			
10	3/8"	-06	Q03611041A-06-06	3/8"	60.5	ø33	24			

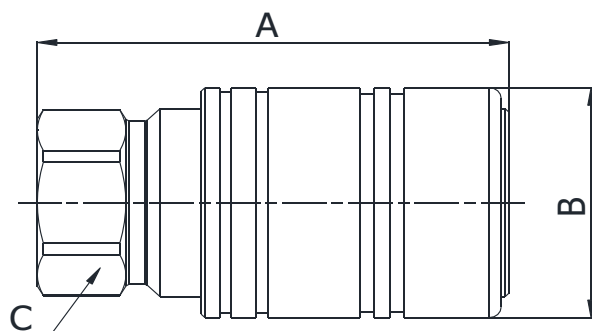

Q03611341A

NPT TERMINATION ENDS
TO ANSI B 1.20.3

SIZE			PART NUMBER	THREAD	DIMENSIONS mm					
DN	Inch	Dash	Female coupling		A	B	C			
6.3	1/4"	-04	Q03611341A-04-04	1/4"-NPT	53.5	ø27	19			
10	3/8"	-06	Q03611341A-06-06	3/8"-NPT	60.5	ø33	24			

PUSH-PULL POPPET VALVE



Pressure Drop

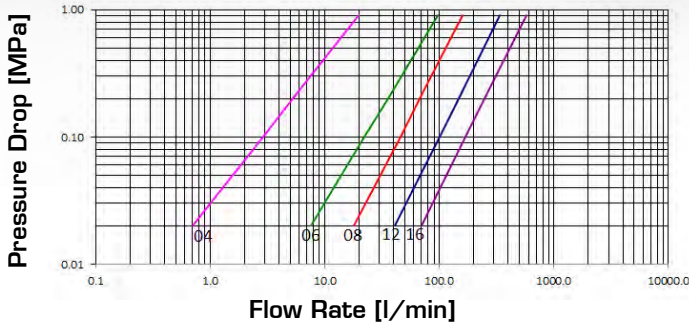

Pressure Drop

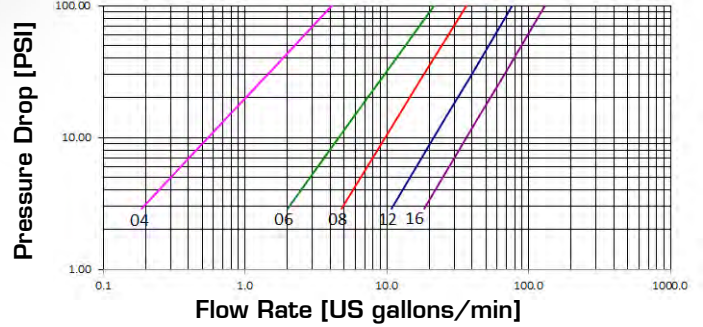

TECHNICAL DATA

SIZE			MPa		FLOW RATE		N		OIL SPILLAGE Connection/ Disconnection		MINIMUM BURST PRESSURE				CONNECTION/ DISCONNECTION UNDER PRESSURE
DN	inch	Dash	MPa	PSI	l/min	US GPM	N	lb.	cc.	cubic inch	Female		M & F		
											MPa	PSI	MPa	PSI	
6.3	1/4	04	35	5075	5	1.3	80	178	0.7	0.043	180	26100	145	21025	Not allowed
10	3/8	06	31.5	4568	35	9.2	105	233	1.4	0.085	150	21750	130	18850	Not allowed
12.5	1/2	08	30	4350	68	18.0	110	244	2	0.122	140	20300	140	20300	Not allowed
20	3/4	12	25	3625	147	38.8	165	367	7	0.427	120	17400	110	15950	Not allowed
25	1	16	25	3625	250	66.1	215	478	11	0.672	115	16675	120	17400	Not allowed

The rated flow represents the normal operating condition. The maximum recommended flow rate is equal to 1.5 times the rated flow

PRODUCT DESCRIPTION

- Female coupling designed for agriculture applications, connectable with ISO 7241-1 series A male couplings
- PUSH-PULL connection and disconnection system, in case of bulkhead mounting on the external sleeve
- Break-away function according to ISO 5675 (in case of bulkhead mounting on the external sleeve)
- Positive connection by latching balls system
- Shut-off by poppet valve
- High resistant materials
- Dimensions and performances according to ISO 7241 series A

MATERIAL

Female couplings in steel with some hardened areas, in correspondence to the most stressed points. Carbonitrided valve and sleeve, springs in C98 steel, latching balls in high resistance 100 C6 steel, seals in NBR (other materials on request) and back-up ring in PTFE. PU seal on 1/2" female available on request.

WORKING TEMPERATURE

-22°F up to +230°F (-30°C up to +110°C)
For other temperatures, the coupling is assembled with specific seals

SAFETY FACTOR

4:1 for dynamic pressures

IMPULSE PRESSURES

100,000 cycles at 133% of the rated one (freq. 1Hz)

TEST SPECIFICATIONS

ISO 18869

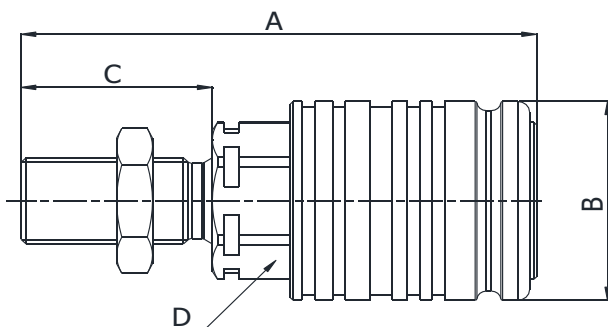

Q01311040A

BSP TERMINATION ENDS
TO ISO 8434-6
BULKHEAD

SIZE			PART NUMBER	THREAD	DIMENSIONS mm					
DN	Inch	Dash	Female coupling		A	B	C	D		
12.5	1/2"	-08	Q01311040A-08-06	3/8"	86.2	ø38	32	27		

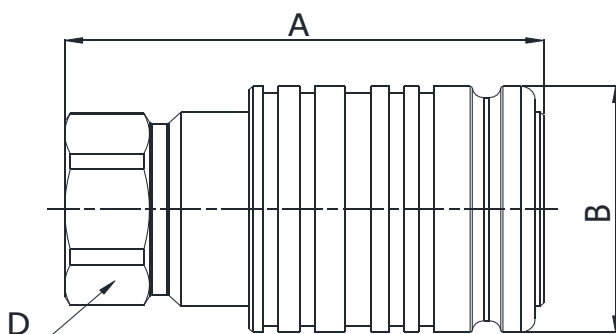

Q01311041A

BSP TERMINATION ENDS
TO DIN 3852
X TYPE

SIZE			PART NUMBER	THREAD	DIMENSIONS mm					
DN	Inch	Dash	Female coupling		A	B	D			
6	1/4"	-04	Q01311041A-04-04	1/4"	58.1	ø26	17			
10	3/8"	-06	Q01311041A-06-04	1/4"	63	ø32	22			
10	3/8"	-06	Q01311041A-06-06	3/8"	64.5	ø32	22			
12.5	1/2"	-08	Q01311041A-08-06	3/8"	66.2	ø38	27			
12.5	1/2"	-08	Q01311041A-08-08	1/2"	67	ø38	27			
12.5	1/2"	-08	Q01311041A-08-12	3/4"	73.2	ø38	34			
20	3/4"	-12	Q01311041A-12-08	1/2"	85.7	ø48	34			
20	3/4"	-12	Q01311041A-12-12	3/4"	87.7	ø48	34			
25	1"	-16	Q01311041A-16-12	3/4"	97.9	ø54	41			
25	1"	-16	Q01311041A-16-16	1"	97.9	ø54	41			

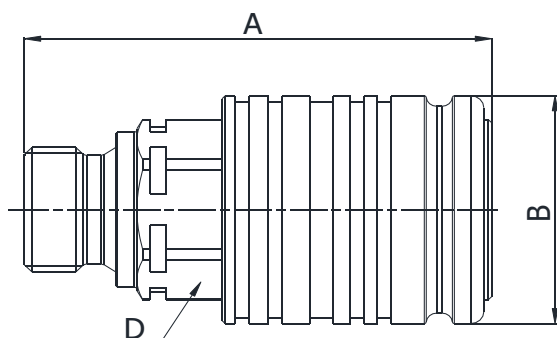

Q01311050A

BSP TERMINATION ENDS
TO ISO 8434-6

SIZE			PART NUMBER	THREAD	DIMENSIONS mm					
DN	Inch	Dash	Female coupling		A	B	D			
12.5	1/2"	-08	Q01311050A-08-06	3/8"	68.9	ø38	27			
12.5	1/2"	-08	Q01311050A-08-08	1/2"	71.4	ø38	27			

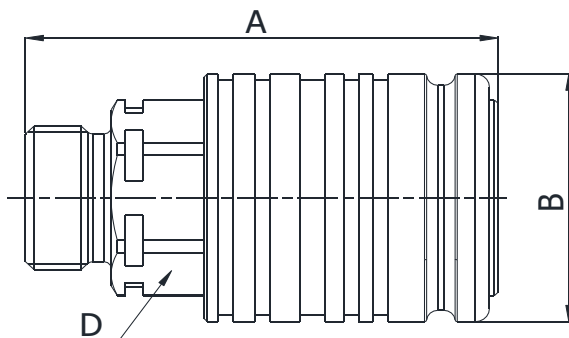

Q01311110A

METRIC TERMINATION ENDS
TO ISO 8434-1
L SERIES

SIZE			PART NUMBER Female coupling	THREAD	DIMENSIONS mm					
DN	Inch	Dash			A	B	D			
10	3/8"	-06	Q01311110A-06-12	M12x1,5	61	ø32	22			
10	3/8"	-06	Q01311110A-06-14	M14x1,5	61	ø32	22			
10	3/8"	-06	Q01311110A-06-16	M16x1,5	61	ø32	22			
10	3/8"	-06	Q01311110A-06-18	M18x1,5	61	ø32	22			
12.5	1/2"	-08	Q01311110A-08-12	M12x1,5	66.2	ø38	27			
12.5	1/2"	-08	Q01311110A-08-14	M14x1,5	65.2	ø38	27			
12.5	1/2"	-08	Q01311110A-08-16	M16x1,5	66.2	ø38	27			
12.5	1/2"	-08	Q01311110A-08-18	M18x1,5	65.2	ø38	27			
12.5	1/2"	-08	Q01311110A-08-22	M22x1,5	66.2	ø38	27			
12.5	1/2"	-08	Q01311110A-08-26	M26x1,5	66.2	ø38	30			
20	3/4"	-12	Q01311110A-12-22	M22x1,5	85.7	ø48	34			
20	3/4"	-12	Q01311110A-12-26	M26x1,5	85.7	ø48	34			
20	3/4"	-12	Q01311110A-12-30	M30x2	87.7	ø48	34			
25	1"	-16	Q01311110A-16-26	M26x1,5	94.5	ø54	41			
25	1"	-16	Q01311110A-16-30	M30x2	96.5	ø54	41			
25	1"	-16	Q01311110A-16-36	M36x2	96.5	ø54	41			

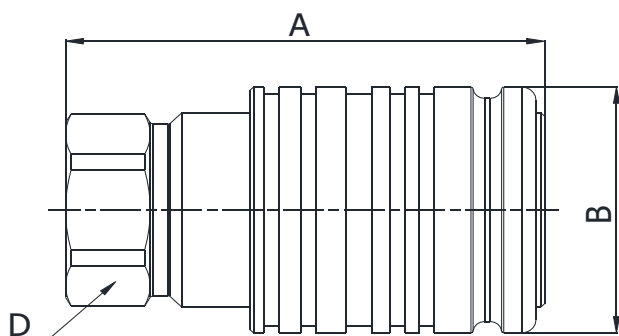

Q01311141A

METRIC TERMINATION ENDS
TO DIN 3852 X TYPE

SIZE			PART NUMBER Female coupling	THREAD	DIMENSIONS mm					
DN	Inch	Dash			A	B	D			
10	3/8"	-06	Q01311141A-06-16	M16x1,5	64.5	ø32	22			
12.5	1/2"	-08	Q01311141A-08-18	M18x1,5	66.2	ø38	27			
12.5	1/2"	-08	Q01311141A-08-20	M20x1,5	67	ø38	27			
12.5	1/2"	-08	Q01311141A-08-22	M22x1,5	67	ø38	27			
20	3/4"	-12	Q01311141A-12-22	M22x1,5	84.7	ø48	34			

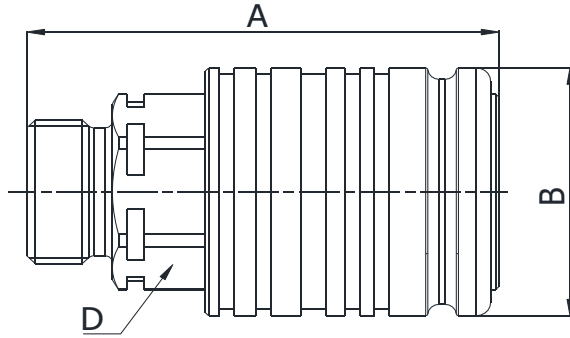

Q0131120A

METRIC TERMINATION ENDS
TO ISO 8434-1
S SERIES

SIZE			PART NUMBER	THREAD	DIMENSIONS mm				
DN	Inch	Dash			Female coupling	A	B	D	
10	3/8"	-06	Q0131120A-06-16	M16x1,5	62	ø32	22		
10	3/8"	-06	Q0131120A-06-18	M18x1,5	62	ø32	22		
12.5	1/2"	-08	Q0131120A-08-18	M18x1,5	66.2	ø38	27		
12.5	1/2"	-08	Q0131120A-08-20	M20x1,5	66.2	ø38	27		
12.5	1/2"	-08	Q0131120A-08-24	M24x1,5	68.2	ø38	27		
25	1"	-16	Q0131120A-16-30	M30x2	98.5	ø54	41		
25	1"	-16	Q0131120A-16-36	M36x2	100.5	ø54	41		
25	1"	-16	Q0131120A-16-42	M40x2	102.5	ø54	46		

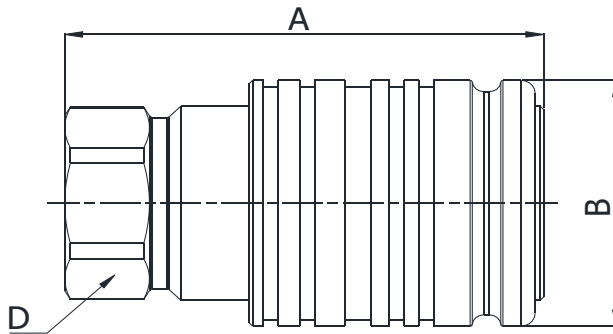

Q0131191A

METRIC TERMINATION ENDS
TO DIN 3852 X TYPE

SIZE			PART NUMBER	THREAD	DIMENSIONS mm				
DN	Inch	Dash			Female coupling	A	B	D	
12.5	1/2"	-08	Q0131191A-08-16*	M16x1,5	66.7	ø38	27		
12.5	1/2"	-08	Q0131191A-08-18*	M18x1,5	68.2	ø38	27		
12.5	1/2"	-08	Q0131191A-08-22	M22x1,5	67	ø38	27		

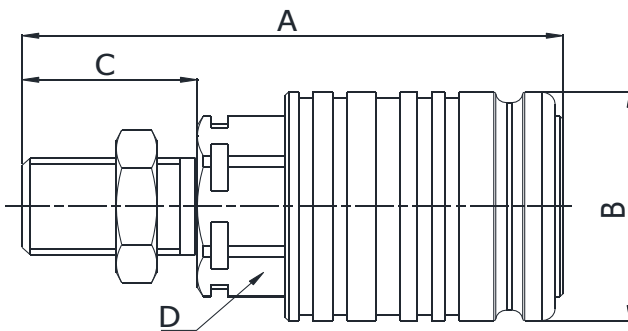

Q01311770A

METRIC TERMINATION END
TO ISO 8434-1
BULKHEAD L SERIES

SIZE			PART NUMBER	THREAD	DIMENSIONS mm				
DN	Inch	Dash			Female coupling	A	B	C	D
12.5	1/2"	-08	Q01311770A-08-18	M18x1,5	90.2	ø38	36	27	

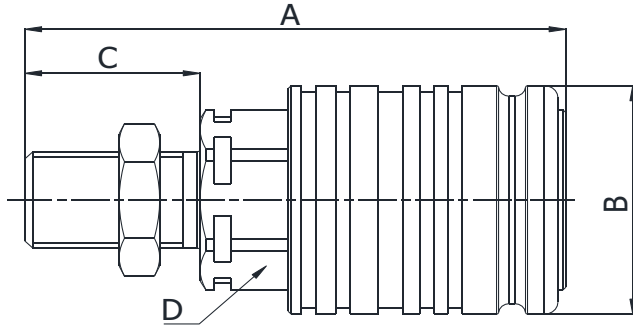

Q01311770B

METRIC TERMINATION END
TO ISO 8434-1
BULKHEAD L SERIES

SIZE			PART NUMBER	THREAD	DIMENSIONS mm					
DN	Inch	Dash			Female coupling	A	B	C	D	
10	3/8"	-06	Q01311770B-06-12	M12x1,5	76	ø32	25	22		
10	3/8"	-06	Q01311770B-06-14	M14x1,5	75	ø32	25	22		
10	3/8"	-06	Q01311770B-06-16	M16x1,5	75	ø32	26	22		
10	3/8"	-06	Q01311770B-06-18	M18x1,5	75	ø32	26	22		
12.5	1/2"	-08	Q01311770B-08-14	M14x1,5	80.2	ø38	25	27		
12.5	1/2"	-08	Q01311770B-08-16	M16x1,5	80.2	ø38	26	27		
12.5	1/2"	-08	Q01311770B-08-18	M18x1,5	80.2	ø38	26	27		
12.5	1/2"	-08	Q01311770B-08-22	M22x1,5	81.2	ø38	27	27		
12.5	1/2"	-08	Q01311770B-08-26	M26x1,5	82.2	ø38	28	30		
20	3/4"	-12	Q01311770B-12-22	M22x1.5	100.7	ø48	27	34		
20	3/4"	-12	Q01311770B-12-26	M26x1.5	101.7	ø48	28	34		
20	3/4"	-12	Q01311770B-12-30	M30x2	105.7	ø48	32	34		
25	1"	-16	Q01311770B-16-30	M30x2	114.5	ø54	32	41		

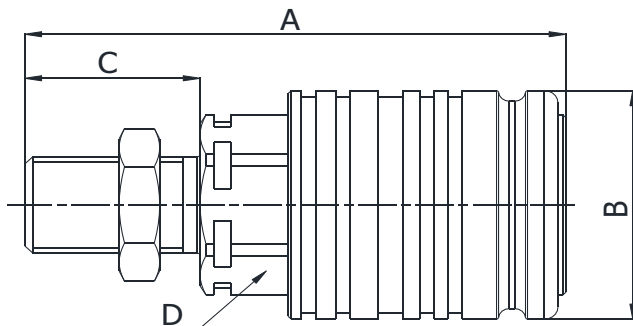

Q01311870B

METRIC TERMINATION END
TO ISO 8434-1
BULKHEAD S SERIES

SIZE			PART NUMBER	THREAD	DIMENSIONS mm					
DN	Inch	Dash			Female coupling	A	B	C	D	
10	3/8"	-06	Q01311870B-06-16	M16x1,5	76	ø32	27	22		
10	3/8"	-06	Q01311870B-06-18	M18x1,5	76	ø32	27	22		
12.5	1/2"	-08	Q01311870B-08-18	M18x1,5	81.2	ø38	27	27		
12.5	1/2"	-08	Q01311870B-08-20	M20x1,5	81.2	ø38	27	27		
12.5	1/2"	-08	Q01311870B-08-24	M24x1,5	83.2	ø38	29	27		
20	3/4"	-12	Q01311870B-12-30	M30x2	107.7	ø48	34	34		
25	1"	-16	Q01311870B-16-36	M36x2	118.5	ø54	36	41		

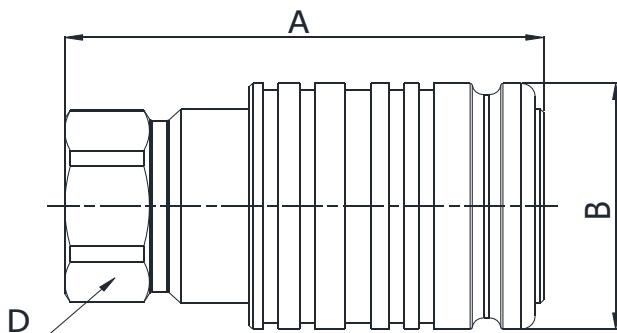

Q01311341A

NPT TERMINATION END
TO ANSI B 1.20.3 STANDARD

SIZE			PART NUMBER	THREAD	DIMENSIONS mm				
DN	Inch	Dash			Female coupling	A	B	D	
6	1/4"	-04	Q01311341A-04-04	1/4" NPTF	58	ø26	17		
10	3/8"	-06	Q01311341A-06-06	3/8" NPTF	64.5	ø32	22		
12.5	1/2"	-08	Q01311341A-08-08	1/2" NPTF	67	ø38	27		
20	3/4"	-12	Q01311341A-16-12	3/4" NPTF	97.9	ø54	41		
25	1"	-16	Q01311341A-16-16	1" NPTF	97.9	ø54	41		

Q.SAFE 378

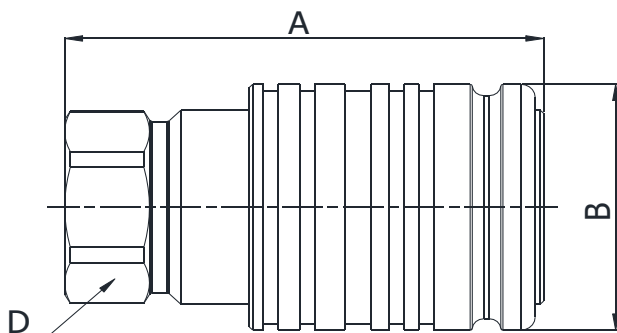

Q01311301A

SAE TERMINATION ENDS
TO SAE J1926-1

SIZE			PART NUMBER	THREAD	DIMENSIONS mm				
DN	Inch	Dash			Female coupling	A	B	D	
10	3/8"	-06	Q01311301A-06-06*	9/16"-18 UNF	64.5	ø32	22		
12.5	1/2"	-08	Q01311301A-08-08	3/4"-16 UNF	67	ø38	27		
12.5	1/2"	-08	Q01311301A-08-10	7/8"-14 UNF	69	ø38	27		

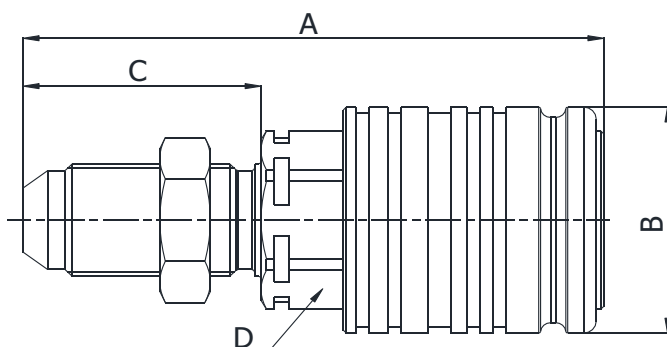

Q01311230A

SAE TERMINATION END
TO ISO 8434-2
BULKHEAD

SIZE			PART NUMBER	THREAD	DIMENSIONS mm				
DN	Inch	Dash			Female coupling	A	B	C	D
12.5	1/2"	-08	Q01311230A-08-08	3/4"-16 UNF	91.8	ø38	37.6	27	
12.5	1/2"	-08	Q01311230A-08-10	7/8"-14 UNF	95.3	ø38	41.1	27	

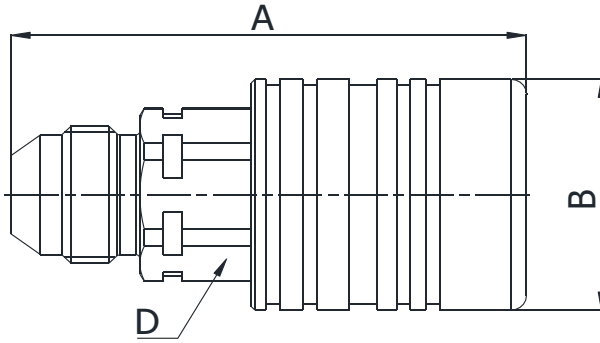

Q01311250A

SAE TERMINATION END
TO ISO 8434-2

SIZE			PART NUMBER	THREAD	DIMENSIONS mm					
DN	Inch	Dash	Female coupling		A	B	D			
10	3/8"	-06	Q01311250A-06-08	3/4"-16 UNF	66.7	ø32	22			

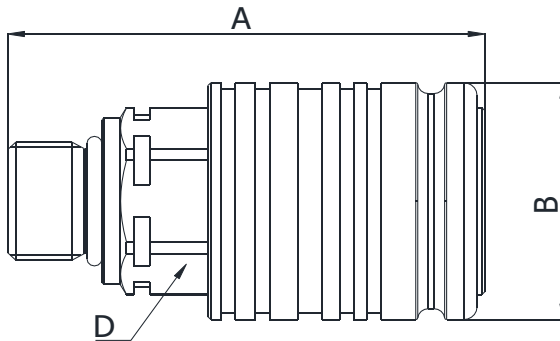

Q01311320A

ORB TERMINATION ENDS
TO SAE J1926-2
S SERIES

SIZE			PART NUMBER	THREAD	DIMENSIONS mm					
DN	Inch	Dash	Female coupling		A	B	D			
12.5	1/2"	-08	Q01311320A-08-08	3/4"-16 UNF	68.2	ø38	27			

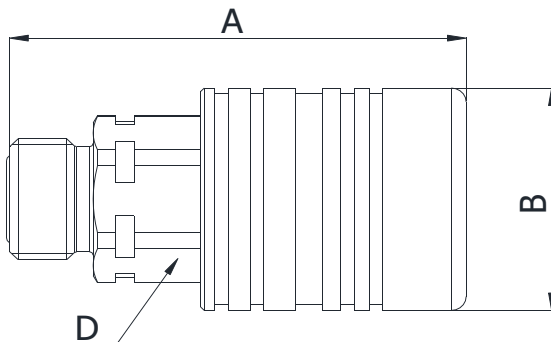

Q01311240A

ORFS TERMINATION ENDS
TO ISO 8434-3

SIZE			PART NUMBER	THREAD	DIMENSIONS mm					
DN	Inch	Dash	Female coupling		A	B	D			
10	3/8"	-06	Q01311240A-06-04	9/16"-18 UN	60.8	ø32	22			
10	3/8"	-06	Q01311240A-06-06	11/16"-16 UN	61.2	ø32	22			
12.5	1/2"	-08	Q01311240A-08-08	13/16"-16 UN	66.2	ø38	27			
25	1"	-16	Q01311240A-16-16	1.7/16"-12 UN	100	ø54	41			

PUSH-PULL CONNECTABLE UNDER PRESSURE



Pressure Drop

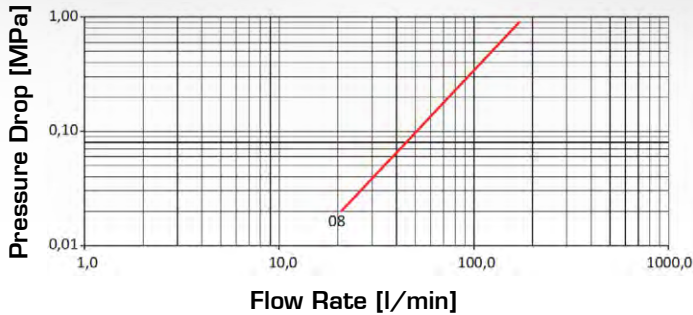

Pressure Drop

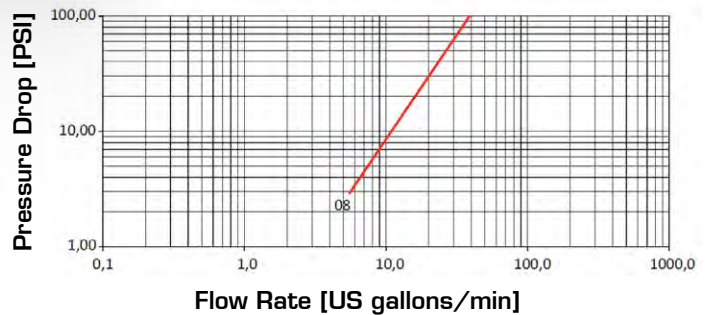

Q.SAFE 380

TECHNICAL DATA

SIZE		MPa		FLOW RATE		N		OIL SPILLAGE Connection/Disconnection		MINIMUM BURST PRESSURE				CONNECTION/DISCONNECTION UNDER PRESSURE		
DN	inch	Dash	MPa	PSI	l/min	US GPM	N	lb.	cc.	cubic inch	Female		M & F			
											MPa	PSI	MPa	PSI		
12.5	½	08	30	4350	68	18.0	110	244	2	0.122	120	17400	140	20300	Connection only	
										With 0 MPa pressure						

The rated flow represents the normal operating condition. The maximum recommended flow rate is equal to 1.5 times the rated flow

PRODUCT DESCRIPTION

- Female coupling designed for agriculture applications, connectable with ISO 7241-1 series A male couplings
- Connectable under pressure thanks to a frontal micro-valve
- Push-Pull connection and disconnection system, in case of bulkhead mounting on the external sleeve
- Break-away function according to ISO 5675 (in case of bulkhead mounting on the external sleeve)
- Positive connection by latching balls system
- Shut-off by poppet valve
- High resistant materials
- Dimensions and performances according to ISO 7241 series A

MATERIAL

Female couplings in steel with some hardened areas, in correspondence to the most stressed points. Carbonitrided valve, micro-valve and sleeve, springs in C98 steel, latching balls in 100 C6 steel, seals in NBR and polyurethane (other materials on request) and back-up ring in PTFE. PU seal on ½" female available on request.

WORKING TEMPERATURE

-22°F up to +230°F (-30°C up to +110°C)
For other temperatures, the quick coupling is assembled with specific seals

SAFETY FACTOR

4:1 for dynamic pressures

IMPULSE PRESSURES

100,000 cycles of impulse pressure at 133% of the rated one (freq. 1Hz)

TEST SPECIFICATIONS

ISO 18869

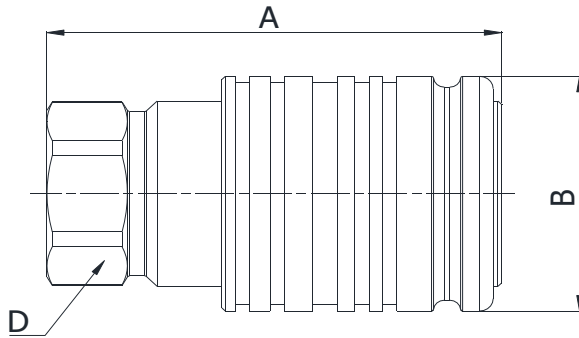

Q01511041A

BSP TERMINATION ENDS
TO DIN 3852 X TYPE

SIZE			PART NUMBER	THREAD	DIMENSIONS mm					
DN	Inch	Dash	Female coupling		A	B	D			
12.5	1/2"	-08	Q01511041A-08-08	1/2"	67	ø38	27			

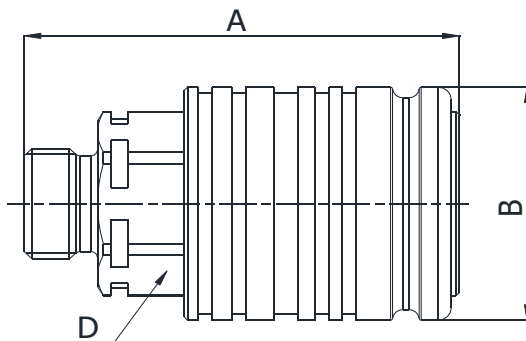

Q01511110A

METRIC TERMINATION END
TO ISO 8434-1
L SERIES

SIZE			PART NUMBER	THREAD	DIMENSIONS mm					
DN	Inch	Dash	Female coupling		A	B	D			
12.5	1/2"	-08	Q01511110A-08-18	M18x1,5	65.2	ø38	27			

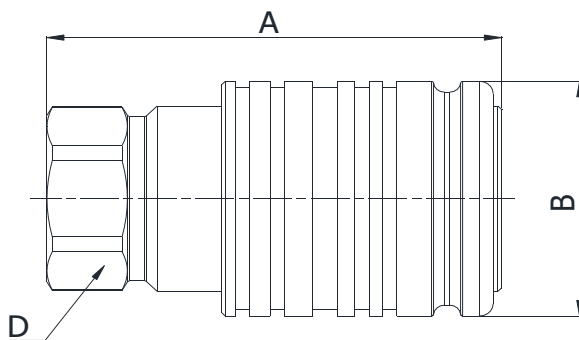

Q01511341A

NPT TERMINATION END
TO ANSI B 1.20.3 STANDARD

SIZE			PART NUMBER	THREAD	DIMENSIONS mm					
DN	Inch	Dash	Female coupling		A	B	D			
12.5	1/2"	-08	Q01511341A-08-08	1/2" NPTF	67	ø38	27			

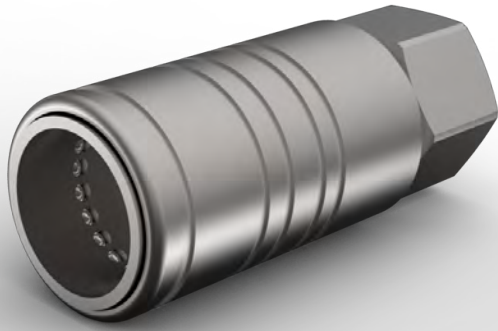

PUSH-PULL FEMALE CONNECTABLE WITH MALE UNDER PRESSURE

Pressure Drop

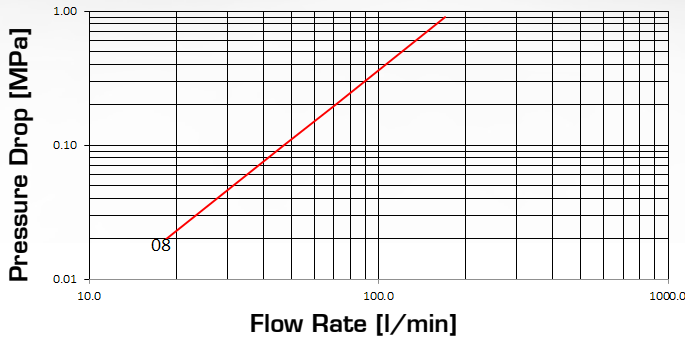

Pressure Drop

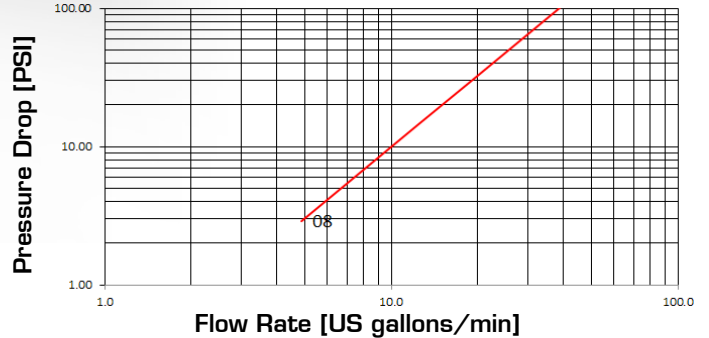

TECHNICAL DATA

SIZE			WORKING PRESSURE (Dynamic)		RATED FLOW at 0.2 MPa of pressure drop		CONNECTION EFFORT		OIL SPILLAGE Connection/ Disconnection		MINIMUM BURST PRESSURE				CONNECTION/ DISCONNECTION UNDER PRESSURE
DN	inch	Dash	MPa	PSI	l/min	US GPM	N	lb.	cc.	cubic inch	Female		M & F		
											MPa	PSI	MPa	PSI	
12.5	1/2	08	30	4350	71	18.8	170	378	2	0.122	125	18125	125	18125	Connection only, with male under pressure

The rated flow represents the normal operating condition. The maximum recommended flow rate is equal to 1.5 times the rated flow

PRODUCT DESCRIPTION

- Connectable with male ISO A under pressure
- Working pressure 30MPa
- Connection/disconnection PUSH-PULL
- No shut-off, Manuli mechanical valve block system
- Installation on hoses with coupling blocked on panel by the sleeve
- Breakaway function according to ISO 5675
- Interchangeable according to ISO 7241 series A
- Wide range of termination end

MATERIAL

Couplings in steel with some stressed area hardened, carbonitrided valve, springs in C98 steel, seals in NBR, back-up ring PTFE. PU seal on 1/2" female available on request.

WORKING TEMPERATURE

-22°F up to +230°F (-30°C up to +110°C)
For other temperatures, the quick coupling is assembled with specific seals

SAFETY FACTOR

4:1 for dynamic pressures

IMPULSE PRESSURES

500,000 cycles (connected and disconnected conditions) at 120% of the rated one (freq. 1Hz)

TEST SPECIFICATIONS

ISO 18869

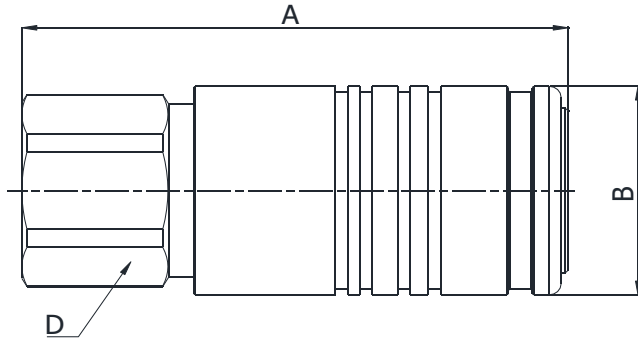

Q01611041A

BSP TERMINATION ENDS
TO DIN 3852 X TYPE

SIZE			PART NUMBER	THREAD	DIMENSIONS mm					
DN	Inch	Dash	Female coupling		A	B	D			
12.5	1/2"	-08	Q01611041A-08-08	1/2"	91.2	ø38	32			

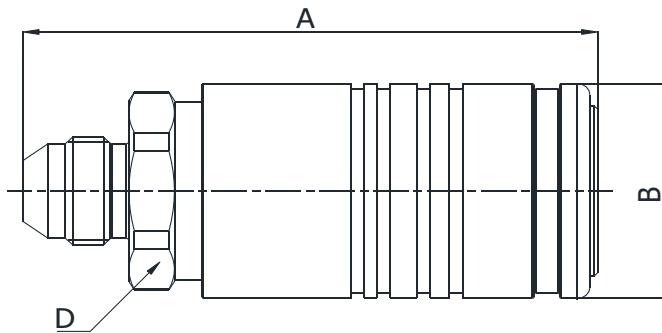

Q01611250A

SAE TERMINATION ENDS
TO ISO 8434-2

SIZE			PART NUMBER	THREAD	DIMENSIONS mm					
DN	Inch	Dash	Female coupling		A	B	D			
12.5	1/2"	-08	Q01611250A-08-08	3/4"- 16 UNF	90.7	ø38	32			



PUSH-PULL FEMALE BOTH PARTS CONNECTABLE UNDER PRESSURE

Pressure Drop

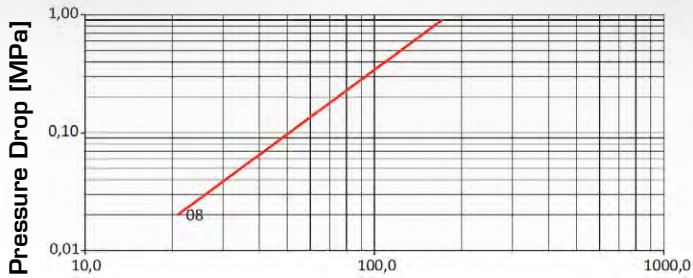

Flow Rate [l/min]

Pressure Drop

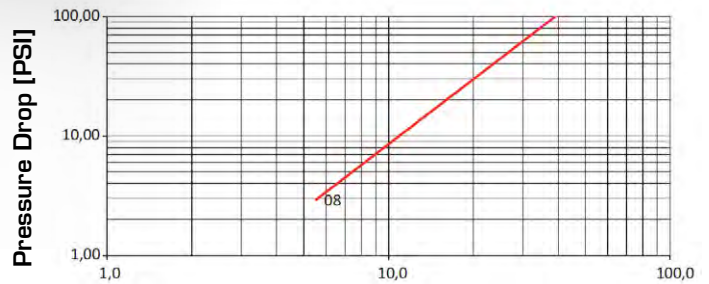

Flow Rate [US gallons/min]

TECHNICAL DATA

SIZE			WORKING PRESSURE (Dynamic)		RATED FLOW at 0.2 MPa of pressure drop		CONNECTION EFFORT		OIL SPILLAGE Connection/ Disconnection		MINIMUM BURST PRESSURE				CONNECTION/ DISCONNECTION UNDER PRESSURE
DN	inch	Dash	MPa	PSI	l/min	US GPM	N	lb.	cc.	cubic inch	Female		M & F		
											MPa	PSI	MPa	PSI	
12.5	½	08	30	4350	71	18.8	170	378	2	0.122	125	18125	125	18125	Connection only, with male and female under pressure
									With 0 MPa of pressure						

The rated flow represents the normal operating condition. The maximum recommended flow rate is equal to 1.5 times the rated flow

PRODUCT DESCRIPTION

- Connectable with male ISO A and female under pressure
- Working pressure 30MPa
- Connection/disconnection PUSH-PULL
- No shut-off, Manuli mechanical valve block system
- Installation on hoses with coupling blocked on panel by the sleeve
- Breakaway function according to ISO 5675
- Interchangeable according to ISO 7241 series A
- Wide range of termination ends

MATERIAL

Couplings in steel with some stressed area hardened, carbonitrided valve, springs in C98 steel, seals in polyurethane and NBR, back-up ring PTFE. PU seal on ½" female available on request.

WORKING TEMPERATURE

-22°F up to +230°F (-30°C up to +110°C)
For other temperatures, the quick coupling is assembled with specific seals

SAFETY FACTOR

4:1 for dynamic pressures

IMPULSE PRESSURES

500,000 cycles (connected and disconnected conditions) at 120% of the rated one (freq. 1Hz)

TEST SPECIFICATIONS

ISO 18869

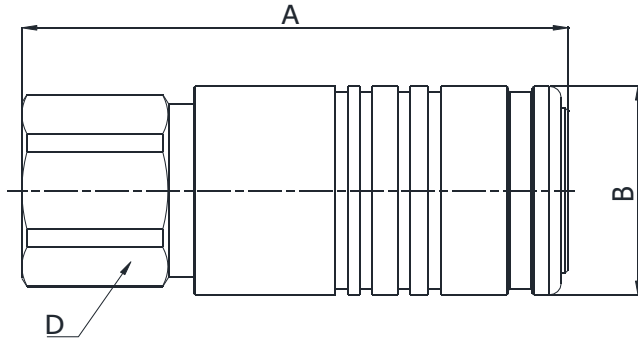

Q01711041A

BSP TERMINATION ENDS
TO DIN 3852 X TYPE

SIZE			PART NUMBER	THREAD	DIMENSIONS mm					
DN	Inch	Dash	Female coupling		A	B	D			
12.5	1/2"	-08	Q01711041A-08-08	1/2"	91.2	ø38	32			

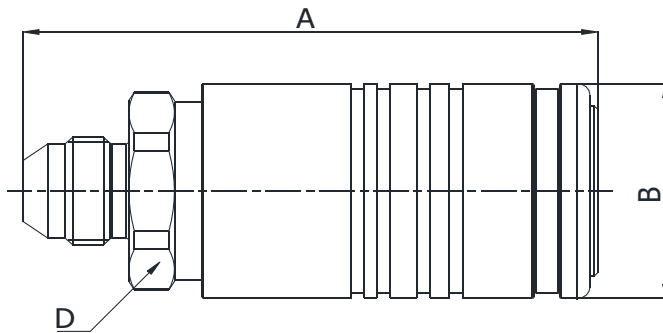

Q01711250A

SAE TERMINATION ENDS
TO ISO 8434-2

SIZE			PART NUMBER	THREAD	DIMENSIONS mm					
DN	Inch	Dash	Female coupling		A	B	D			
12.5	1/2"	-08	Q01711250A-08-08	3/4"- 16 UNF	90.7	ø38	32			

385 Q.SAFE

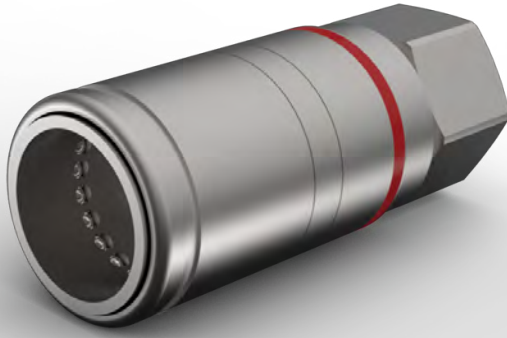

PUSH-PULL FEMALE CONNECTABLE WITH MALE UNDER PRESSURE

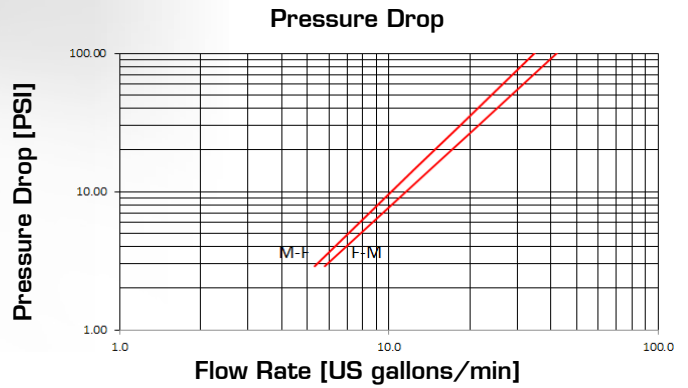
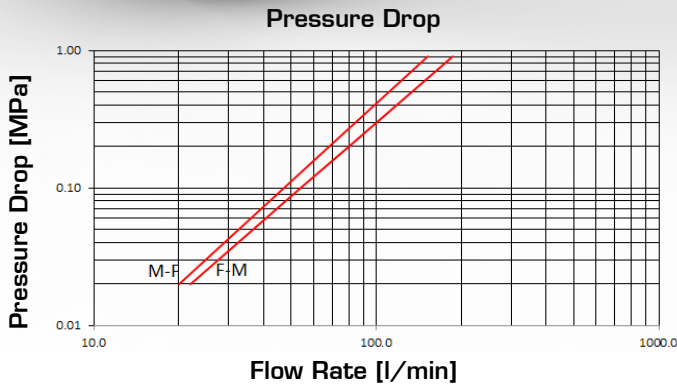

TECHNICAL DATA

SIZE		WORKING PRESSURE [Dynamic]		RATED FLOW at 0.2 MPa of pressure drop			CONNECTION EFFORT		OIL SPILLAGE Connection/ Disconnection		MINIMUM BURST PRESSURE				CONNECTION/ DISCONNECTION UNDER PRESSURE	
DN	inch	Dash	MPa	PSI	Flow direction	l/min	US GPM	N	lb.	cc.	cubic inch	Male		M & F		Connection only, with male under pressure
												MPa	PSI	MPa	PSI	
12.5	½	08	30	4350	F → M	80	21.1	230	511	2	0.122	125	18125	125	18125	Connection only, with male under pressure
					M → F	68	18.0									

The rated flow represents the normal operating condition. The maximum recommended flow rate is equal to 1.5 times the rated flow

PRODUCT DESCRIPTION

- Connectable with male ISO A under pressure
- Working pressure 30MPa
- Connection/disconnection PUSH-PULL
- No shut-off, Manuli mechanical valve block system
- Installation on pipe and ports
- Breakaway function according to ISO 5675
- Interchangeable according to ISO 7241 series A
- Wide range of termination ends
- According to all requirements of ISO 5675

MATERIAL

Couplings in steel with some stressed area hardened, carbonitrided valve, springs in C98 steel, seals in NBR, back-up ring PTFE. PU seal on ½" female available on request.

WORKING TEMPERATURE

-22°F up to +230°F (-30°C up to +110°C)
For other temperatures, the quick coupling is assembled with specific seals

SAFETY FACTOR

4:1 for dynamic pressures

IMPULSE PRESSURES

500,000 cycles (connected and disconnected conditions) at 120% of the rated one (freq. 1Hz)

TEST SPECIFICATIONS

ISO 18869

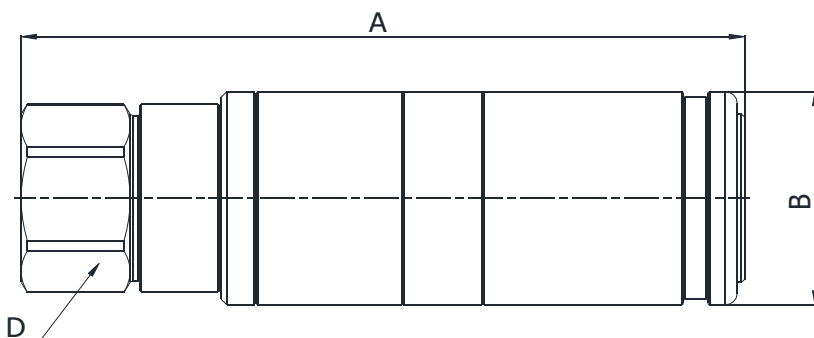

Q01811041A

BSP TERMINATION ENDS
TO DIN 3852 X TYPE

SIZE			PART NUMBER	THREAD	DIMENSIONS mm					
DN	Inch	Dash	Female coupling		A	B	D			
12.5	1/2"	-08	Q01811041A-08-08	1/2"	118.4	ø38	30			

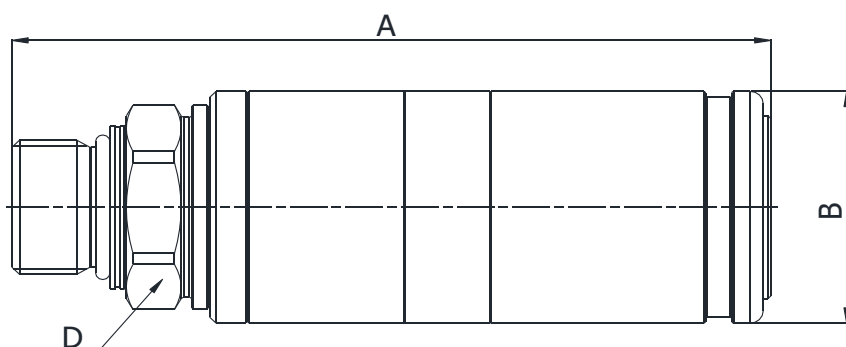

Q01811190A

METRIC TERMINATION ENDS
TO ISO 6149-2

SIZE			PART NUMBER	THREAD	DIMENSIONS mm					
DN	Inch	Dash	Female coupling		A	B	D			
12.5	1/2"	-08	Q01811190A-08-22	M22x1,5	115.9	ø38	30			

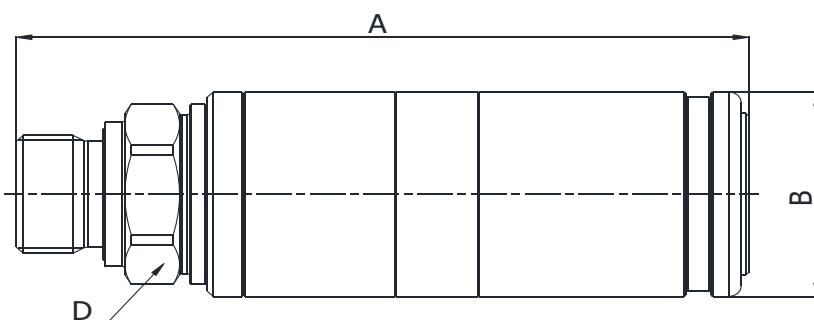

Q01811140A

METRIC TERMINATION ENDS
TO ISO 9974-2

SIZE			PART NUMBER	THREAD	DIMENSIONS mm					
DN	Inch	Dash	Female coupling		A	B	D			
12.5	1/2"	-08	Q01811140A-08-22	M22x1,5	115.9	ø38	30			

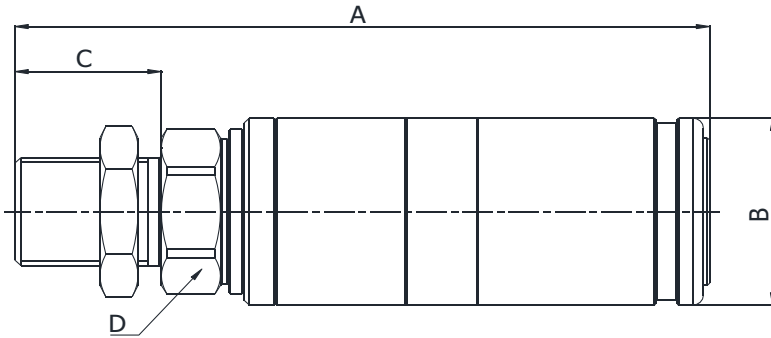

Q01811770B

METRIC TERMINATION ENDS
ISO 8434-1 L SERIES BULKHEAD

SIZE			PART NUMBER	THREAD	DIMENSIONS mm					
DN	Inch	Dash	Female coupling		A	B	C	D		
12.5	1/2"	-08	Q01811770B-08-22	M22x1,5	127.9	ø38	27	30		

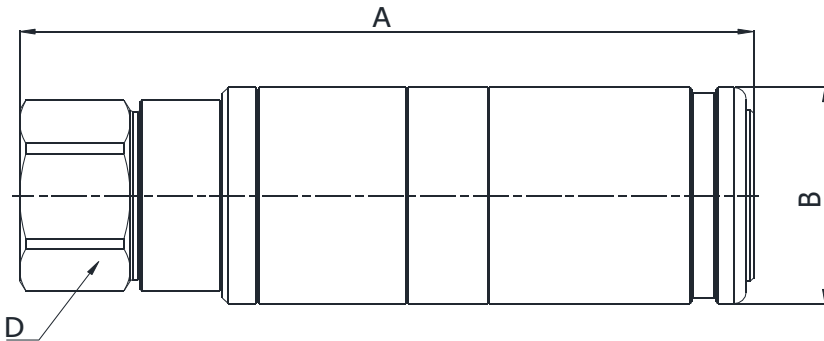

Q01811341A

NPT TERMINATION ENDS
TO ANSI B 1.20.3

SIZE			PART NUMBER	THREAD	DIMENSIONS mm					
DN	Inch	Dash	Female coupling		A	B	D			
12.5	1/2"	-08	Q01811341A-08-08	1/2" NPTF	118.4	ø38	30			

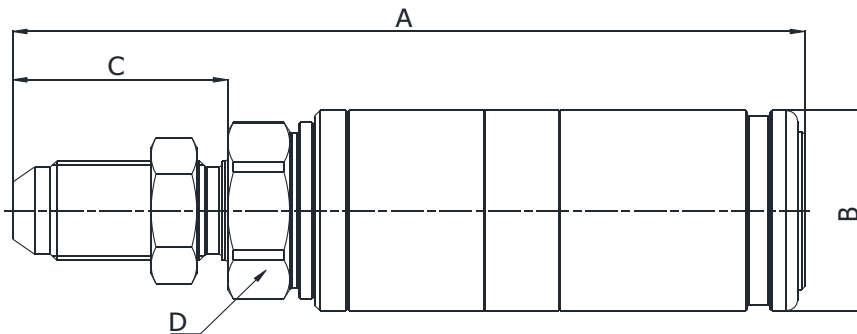

Q01811230A

SAE TERMINATION ENDS
ISO 8434-2 BULKHEAD

SIZE			PART NUMBER	THREAD	DIMENSIONS mm					
DN	Inch	Dash	Female coupling		A	B	C	D		
12.5	1/2"	-08	Q01811230A-08-08	3/4"-16 UNF	138.5	ø38	37.6	30		
12.5	1/2"	-08	Q01811230A-08-10	7/8"-14UNF	142	ø38	40.1	30		

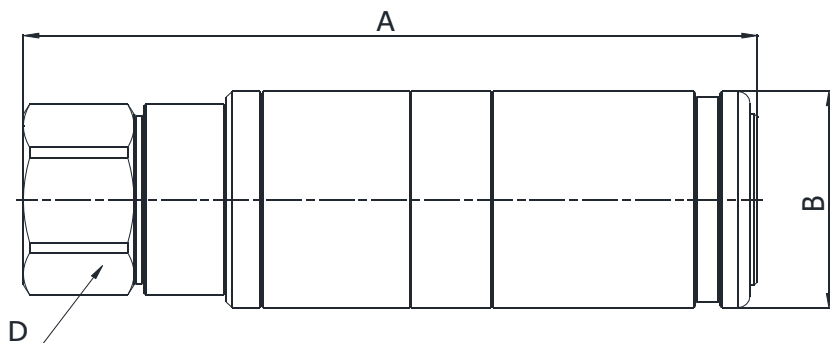

Q01811301A

SAE TERMINATION ENDS
TO SAE J1926-1

SIZE			PART NUMBER	THREAD	DIMENSIONS mm					
DN	Inch	Dash	Female coupling		A	B	D			
12.5	1/2"	-08	Q01811301A-08-08	3/4"-16 UNF	117.4	ø38	30			

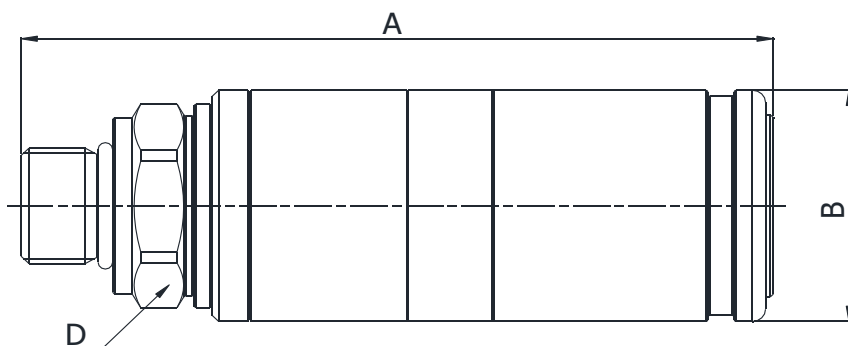

Q01811320A

ORB TERMINATION ENDS
TO SAE J1926-2 S SERIES

SIZE			PART NUMBER	THREAD	DIMENSIONS mm					
DN	Inch	Dash	Female coupling		A	B	D			
12.5	1/2"	-08	Q01811320A-08-08	3/4"-16 UNF	115	ø38	30			
12.5	1/2"	-08	Q01811320A-08-10	7/8"-14UNF	117	ø38	30			

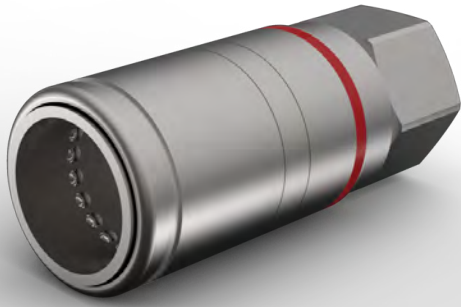

PUSH-PULL FEMALE CONNECTABLE WITH BOTH PARTS UNDER PRESSURE

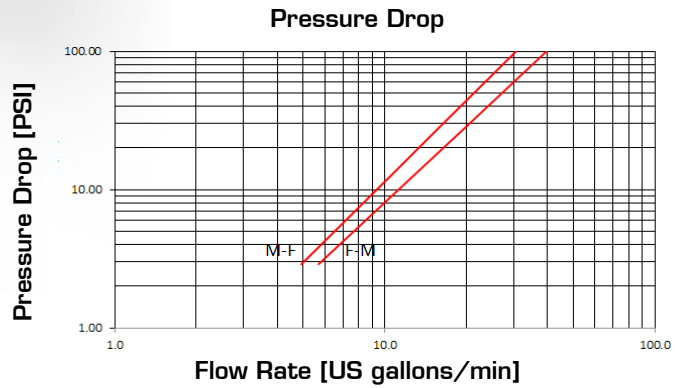
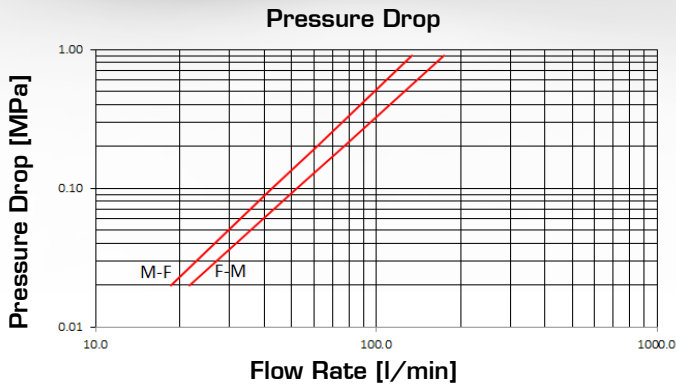

TECHNICAL DATA

SIZE		MPa	FLOW RATE	N	OIL SPILLAGE Connection/Disconnection	MINIMUM BURST PRESSURE	CONNECTION/DISCONNECTION UNDER PRESSURE									
DN	inch	Dash	MPa	PSI	Flow direction	l/min	US GPM	N	lb.	cc.	cubic inch	Male MPa	Male PSI	M & F MPa	M & F PSI	Connection only, with male & female under pressure
12.5	½	08	30	4350	F → M	80	21.1	230	511	2.5	0.153	125	18125	125	18125	
					M → F	68	18.0			With OMPa of pressure						

The rated flow represents the normal operating condition. The maximum recommended flow rate is equal to 1.5 times the rated flow

PRODUCT DESCRIPTION

- Connectable with male ISO A and female under pressure
- Working pressure 30MPa
- Connection/disconnection PUSH-PULL
- No shut-off, Manuli mechanical valve block system
- Installation on pipe and ports
- Breakaway function according to ISO 5675
- Interchangeable according to ISO 7241 series A
- Wide range of termination ends
- According to all requirements of ISO 5675

MATERIAL

Couplings in steel with some stressed area hardened, carbonitrided valve, springs in C98 steel, seals in polyurethane and NBR, back-up ring PTFE. PU seal on ½" female available on request.

WORKING TEMPERATURE

-22°F up to +230°F (-30°C up to +110°C)
For other temperatures, the quick coupling is assembled with specific seals

SAFETY FACTOR

4:1 for dynamic pressures

IMPULSE PRESSURES

500,000 cycles (connected and disconnected conditions) at 120% of the rated one (freq. 1Hz)

TEST SPECIFICATIONS

ISO 18869

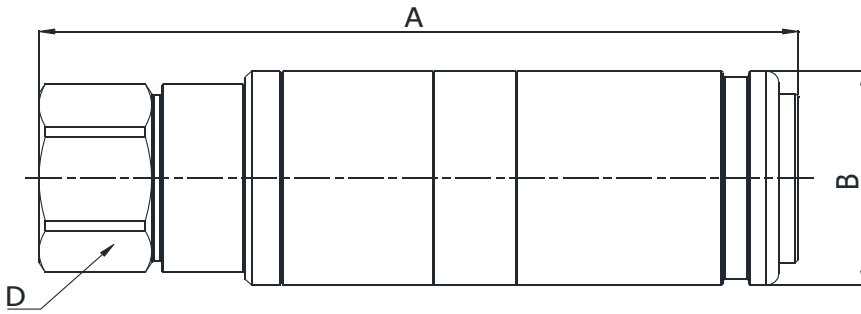

Q01911041A

BSP TERMINATION ENDS
TO DIN 3852 X TYPE

SIZE			PART NUMBER	THREAD	DIMENSIONS mm					
DN	Inch	Dash	Female coupling		A	B	D			
12.5	1/2"	-08	Q01911041A-08-08	1/2"	120.3	ø38	30			

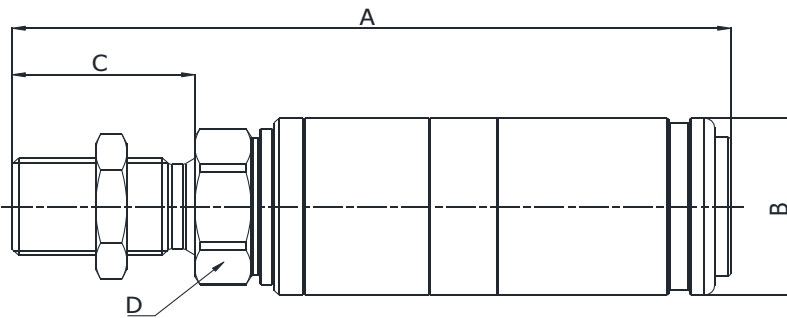

Q01911040A

BSP TERMINATION ENDS
TO ISO 8434-6
BULKHEAD

SIZE			PART NUMBER	THREAD	DIMENSIONS mm					
DN	Inch	Dash	Female coupling		A	B	C	D		
12.5	1/2"	-08	Q01911040A-08-08	1/2"	137.8	ø38	35	30		

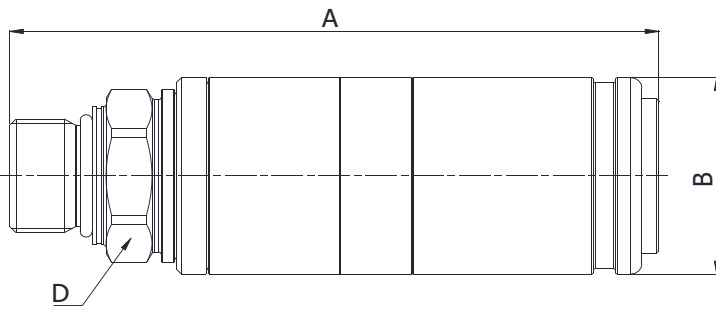

Q01911190A

METRIC TERMINATION ENDS
TO ISO 6149-2

SIZE			PART NUMBER	THREAD	DIMENSIONS mm					
DN	Inch	Dash	Female coupling		A	B	D			
12.5	1/2"	-08	Q01911190A-08-22	M22x1,5	117.8	ø38	30			

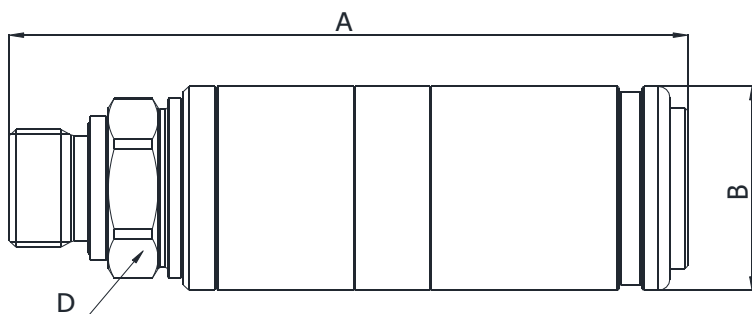

Q0191140A

METRIC TERMINATION ENDS
TO ISO 9974-2

SIZE			PART NUMBER	THREAD	DIMENSIONS mm					
DN	Inch	Dash	Female coupling		A	B	D			
12.5	1/2"	-08	Q0191140A-08-22	M22x1,5	117.8	ø38	30			

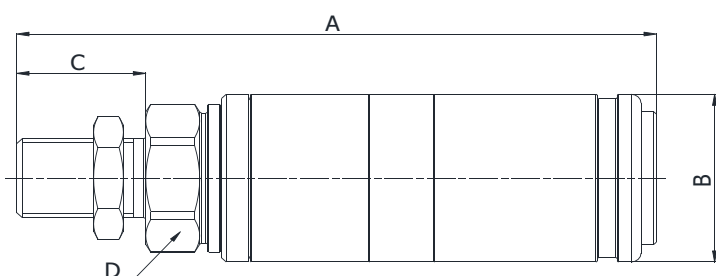

Q01911770B

METRIC TERMINATION ENDS
ISO 8434-1 L SERIES BULKHEAD

SIZE			PART NUMBER	THREAD	DIMENSIONS mm					
DN	Inch	Dash	Female coupling		A	B	C	D		
12.5	1/2"	-08	Q01911770B-08-18	M18x1,5	128.8	ø38	26	30		
12.5	1/2"	-08	Q01911770B-08-22	M22x1,5	129.8	ø38	27	30		

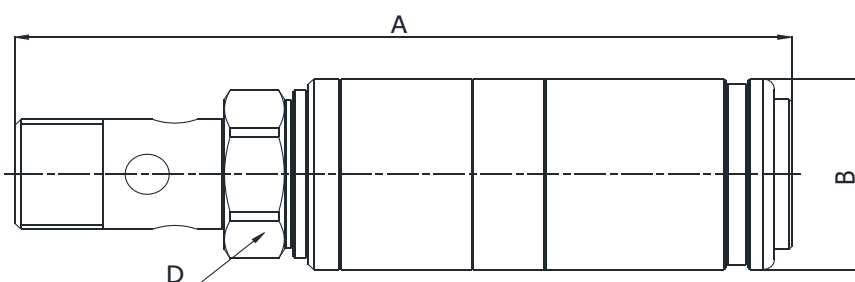

Q01911080A

METRIC TERMINATION ENDS
DIN 7643

SIZE			PART NUMBER	THREAD	DIMENSIONS mm					
DN	Inch	Dash	Female coupling		A	B	D			
12.5	1/2"	-08	Q01911080A-08-22	M22x1,5	140.8	ø38	30			

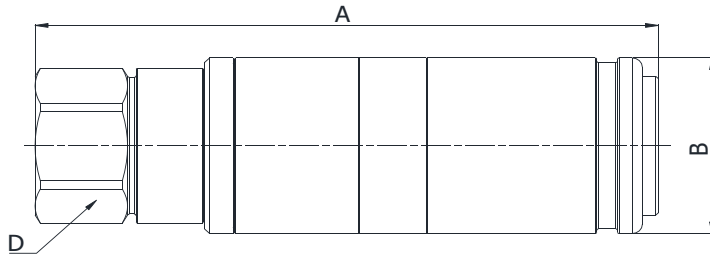

Q01911341A

NPT TERMINATION ENDS
TO ANSI B 1.20.3

SIZE			PART NUMBER	THREAD	DIMENSIONS mm					
DN	Inch	Dash	Female coupling		A	B	D			
12.5	1/2"	-08	Q01911341A-08-08	1/2" NPTF	120.3	ø38	30			

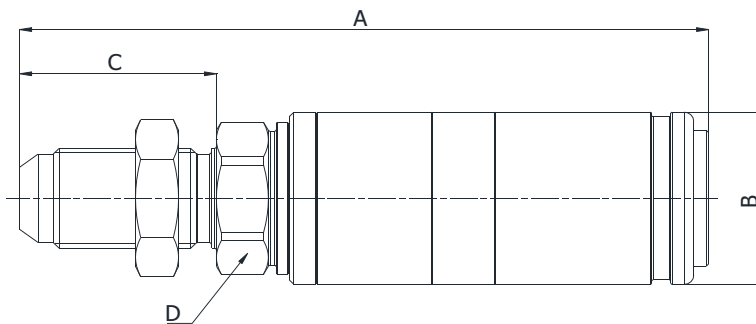

Q01911230A

SAE TERMINATION ENDS
ISO 8434-2 BULKHEAD

SIZE			PART NUMBER	THREAD	DIMENSIONS mm					
DN	Inch	Dash	Female coupling		A	B	D			
12.5	1/2"	-08	Q01911230A-08-10	7/8"-14UNF	143.9	ø38	40.1	30		

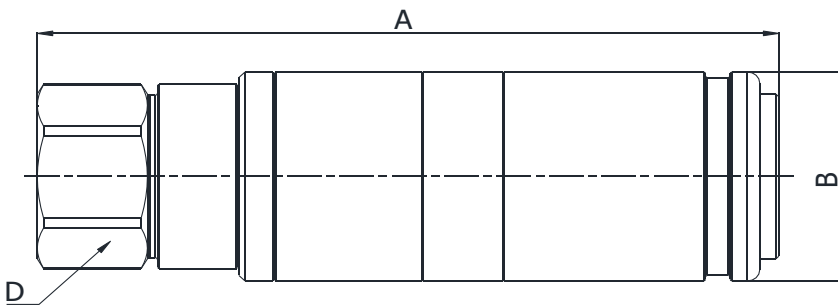

Q01911301A

SAE TERMINATION ENDS
TO SAE J1926-1

SIZE			PART NUMBER	THREAD	DIMENSIONS mm					
DN	Inch	Dash	Female coupling		A	B	D			
12.5	1/2"	-08	Q01911301A-08-08	3/4"-16 UNF	119.3	ø38	30			

393 Q.SAFE

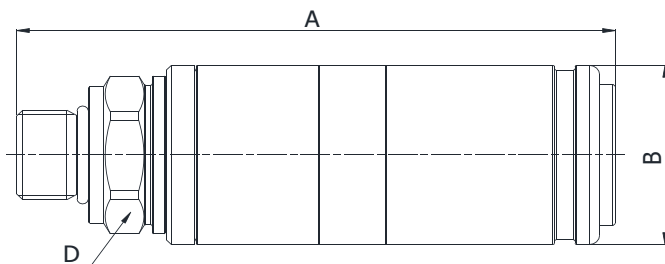

Q01911320A

ORB TERMINATION ENDS
TO SAE J1926-2 S SERIES

SIZE			PART NUMBER	THREAD	DIMENSIONS mm					
DN	Inch	Dash	Female coupling		A	B	D			
12.5	1/2"	-08	Q01911320A-08-08	3/4"-16 UNF	116.9	ø38	30			
12.5	1/2"	-08	Q01911320A-08-10	7/8"-14UNF	118.9	ø38	30			

BRAKING CIRCUIT VALVES



Pressure Drop

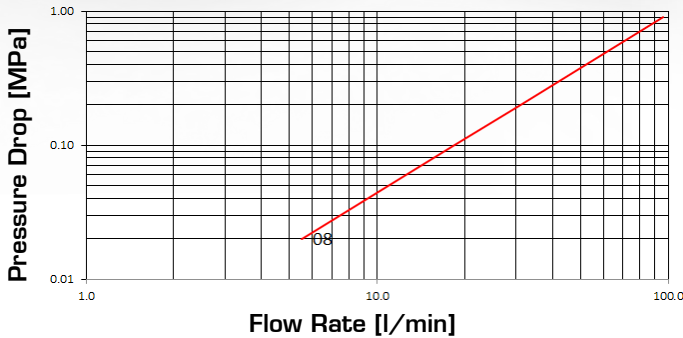

Pressure Drop

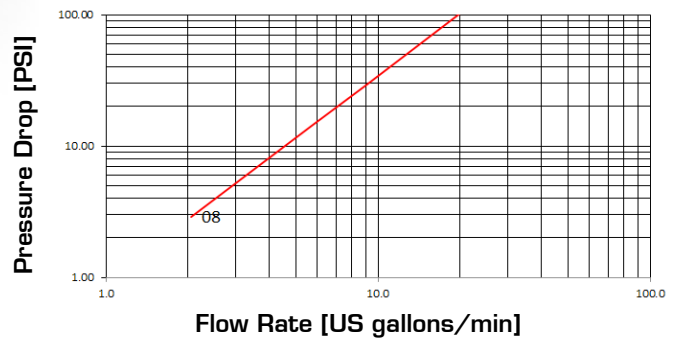

TECHNICAL DATA

SIZE			WORKING PRESSURE [Dynamic]		RATED FLOW at 0.2 MPa of pressure drop		CONNECTION EFFORT		OIL SPILLAGE Connection/Disconnection		MINIMUM BURST PRESSURE						CONNECTION/DISCONNECTION UNDER PRESSURE	
DN	inch	Dash	MPa	PSI	l/min	US GPM	N	lb.	cc.	cubic inch	Male		Female		M & F		Not allowed	
											MPa	PSI	MPa	PSI	MPa	PSI		
12.5	1/2	08	15	2175	31	8.2	110	224	0.02	0.001	130	18850	60	8700	130	18850		

The rated flow represents the normal operating condition. The maximum recommended flow rate is equal to 1.5 times the rated flow

PRODUCT DESCRIPTION

- Trailer brake coupling specially designed to connect the hydraulic breaking system of tractors to trailers
- Connection and disconnection by pulling back the sleeve
- Positive connection by latching balls system
- Shut-off by flat valve
- The male has to be placed on the tractor and the female on the implement
- Interchangeable according to ISO 5676

MATERIAL

Female and male coupling in steel, with some stressed tempered areas. Carbonitrided valve and sleeve, springs in C98 steel, seals in NBR and back-up ring PTFE

WORKING TEMPERATURE

-22°F up to +230°F (-30°C up to +110°C)

SAFETY FACTOR

4:1 for dynamic pressures

TEST SPECIFICATIONS

ISO 18869



Safety cap for male coupling and female coupling with parking included

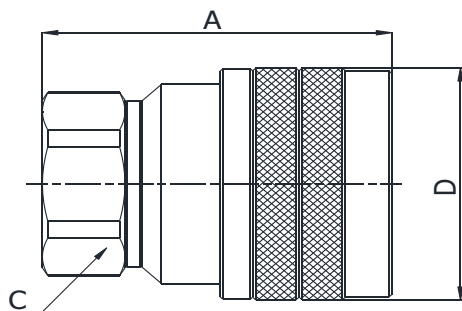

Q04811041A

BSP TERMINATION ENDS
TO DIN 3852 X TYPE

SIZE			PART NUMBER	THREAD	DIMENSIONS mm					
DN	Inch	Dash	Female coupling		A	B	C			
12.5	1/2"	-08	Q04811041A-08-06	3/8"	55,5	ø44	32			
12.5	1/2"	-08	Q04811041A-08-08	1/2"	56,5	ø44	32			

Q.SAFE 396

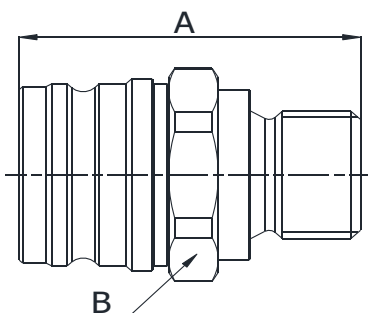

Q04711050A

BSP TERMINATION ENDS
TO ISO 8434-6

SIZE			PART NUMBER	THREAD	DIMENSIONS mm					
DN	Inch	Dash	Male coupling		A	B				
12.5	1/2"	-8	Q04711050A-08-08	1/2"	48	32				

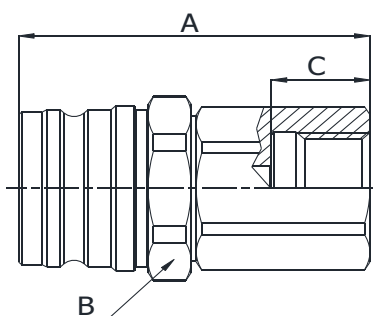

Q04711041A

BSP TERMINATION ENDS
TO DIN 3852 X TYPE

SIZE			PART NUMBER	THREAD	DIMENSIONS mm					
DN	Inch	Dash	Male coupling		A	B	C			
12.5	1/2"	-08	Q04711041A-08-08	1/2" GAS	57	32	16			

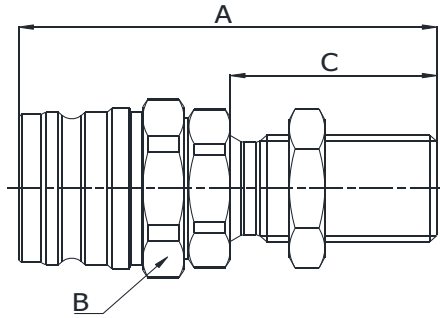

Q04711040A

BSP TERMINATION ENDS
TO ISO 8434-6
BULKHEAD

SIZE			PART NUMBER	THREAD	DIMENSIONS mm					
DN	Inch	Dash	Male coupling		A	B	C			
12.5	1/2"	-08	Q04711040A-08-08	1/2"	70.8	32	35			

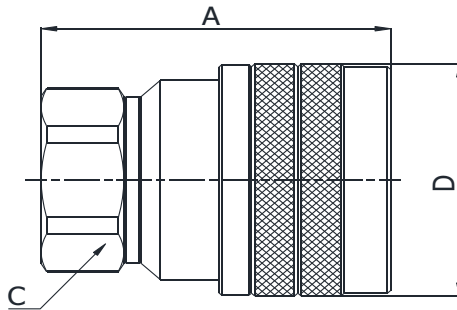

Q04811141A

METRIC TERMINATION ENDS
TO DIN 3852 X TYPE

SIZE			PART NUMBER	THREAD	DIMENSIONS mm					
DN	Inch	Dash	Female coupling		A	B	C			
12.5	1/2"	-08	Q04811141A-08-18	M18x1,5	55,5	ø44	32			

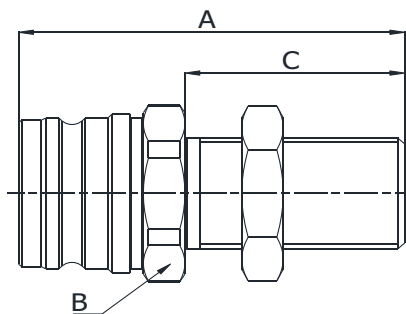

Q04711370A

METRIC TERMINATION ENDS
TO DIN 3863
BULKHEAD

SIZE			PART NUMBER	THREAD	DIMENSIONS mm					
DN	Inch	Dash	Male coupling		A	B	C			
12.5	1/2"	-08	Q04711370A-08-22	M22x1,5	65	32	37			

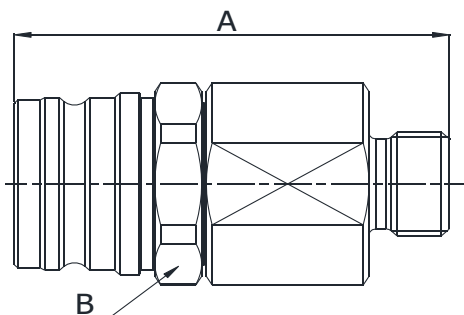

Q0471110A

METRIC TERMINATION ENDS
TO ISO 8434-1
L SERIES

SIZE			PART NUMBER	THREAD	DIMENSIONS mm					
DN	Inch	Dash	Male coupling		A	B				
12.5	1/2"	-08	Q04711110A-08-18	M18x1,5	65	32				
12.5	1/2"	-08	Q04711110A-08-22	M22x1,5	64.7	32				

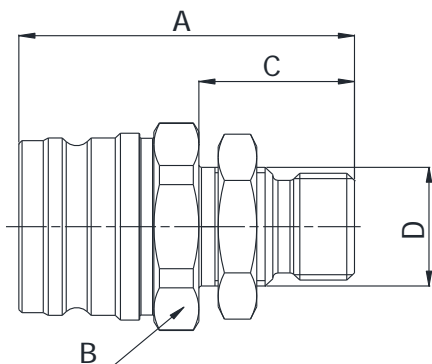

Q04711770A

METRIC TERMINATION END
TO ISO 8434-1
BULKHEAD

SIZE			PART NUMBER	THREAD	DIMENSIONS mm					
DN	Inch	Dash	Male coupling		A	B	C	D		
12.5	1/2"	-08	Q04711770A-08-16	M16x1.5	52.5	32	24.5	M20x1.5		
12.5	1/2"	-08	Q04711770A-08-18	M18x1.5	52	32	24	M20x1.5		

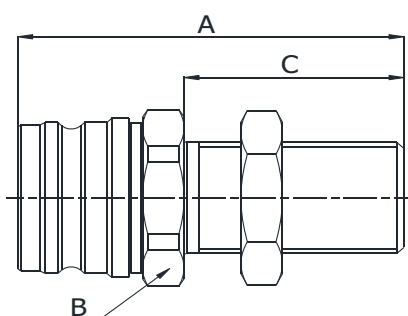

Q04711770A

METRIC TERMINATION END
TO ISO 8434-1
BULKHEAD L SERIES

SIZE			PART NUMBER	THREAD	DIMENSIONS mm					
DN	Inch	Dash	Male coupling		A	B	C			
12.5	1/2"	-08	Q04711770A-08-22	M22x1,5	63	32	35			

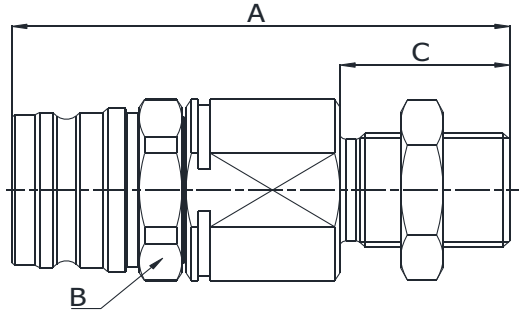

Q04711770B

METRIC TERMINATION END
TO ISO 8434-1
BULKHEAD L SERIES

SIZE			PART NUMBER	THREAD	DIMENSIONS mm					
DN	Inch	Dash	Male coupling		A	B	C			
12.5	1/2"	-08	Q04711770B-08-22	M22x1,5	82	32	28			

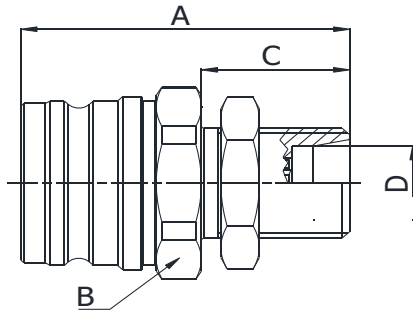

Q04711820A

METRIC TERMINATION END
BULKHEAD

SIZE			PART NUMBER	THREAD	DIMENSIONS mm					
DN	Inch	Dash	Male coupling		A	B	C	D		
12.5	1/2"	-08	Q04711820A-08-20	M20x1,5	51	32	23	ø13,5		

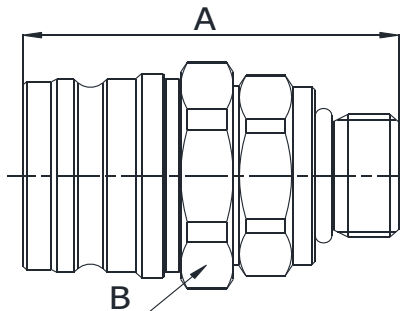

Q04711300A

SAE TERMINATION END
TO SAE J1926-3

SIZE			PART NUMBER	THREAD	DIMENSIONS mm					
DN	Inch	Dash	Male coupling		A	B				
12.5	1/2"	-08	Q04711300A-08-08	3/4"-16 UNF	50	32				

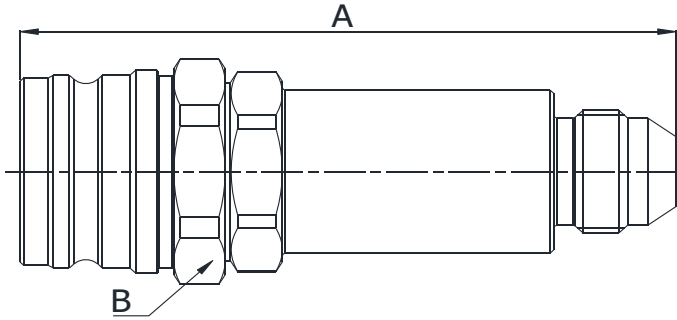

Q04711250A

SAE TERMINATION ENDS
TO ISO 8434-2

SIZE			PART NUMBER	THREAD	DIMENSIONS mm					
DN	Inch	Dash	Male coupling		A	B				
12.5	1/2"	-08	Q04711250A-08-08	3/4"-16 UNF	89.5	32				

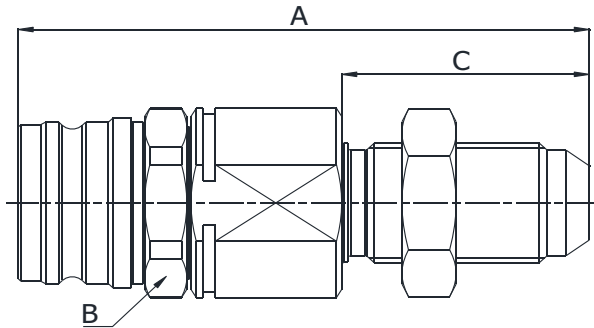

Q04711230A

SAE TERMINATION ENDS
TO ISO 8434-2
BULKHEAD

SIZE			PART NUMBER	THREAD	DIMENSIONS mm					
DN	Inch	Dash	Male coupling		A	B	C			
12.5	1/2"	-08	Q04711230A-08-10	7/8"-14 UNF	94.8	32	40.1			

Q.SAFE
400

AGRICULTURAL VALVES



Pressure Drop

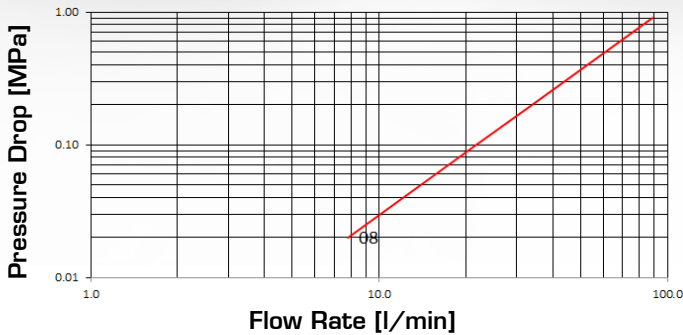

Pressure Drop

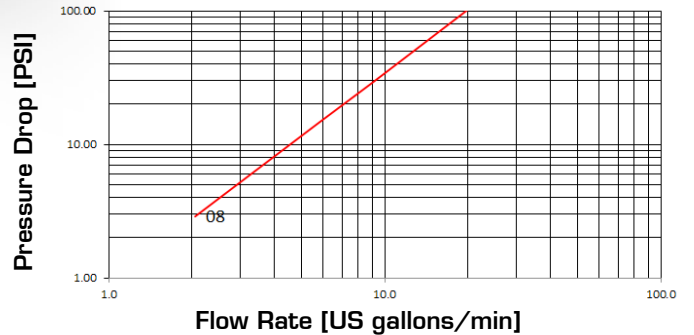

TECHNICAL DATA

SIZE			MPa		FLOW RATE		OIL SPILLAGE Connection/ Disconnection		MINIMUM BURST PRESSURE						CONNECTION/ DISCONNECTION UNDER PRESSURE
DN	inch	Dash	MPa	PSI	l/min	US GPM	cc.	cubic inch	Male		Female		M & F		ALLOWED
									MPa	PSI	MPa	PSI	MPa	PSI	
12.5	½	08	20	2900	34	9.0	0.02	0.001	130	18850	80	11600	140	20300	ALLOWED

The rated flow represents the normal operating condition. The maximum recommended flow rate is equal to 1.5 times the rated flow

PRODUCT DESCRIPTION

- Trailer brake coupling specially designed to connect the hydraulic breaking system of tractors to trailers
- Connection and disconnection by screwing the sleeve
- Connection secured on the thread between the sleeve and the male coupling
- Flat-valve
- Connection and disconnection under pressure allowed
- The male has to be placed on the tractor and the female on the implement
- Interchangeable with similar products available on the market

MATERIAL

Female and male coupling in steel, with hardened stressed areas. Carbonitrided valve, springs in C98 steel, seals in NBR and back-up ring PTFE

WORKING TEMPERATURE

-22°F up to +230°F (-30°C up to +110°C)

SAFETY FACTOR

4:1 for dynamic pressures

TEST SPECIFICATIONS

ISO 18869



Safety cap for male coupling and female coupling with parking included

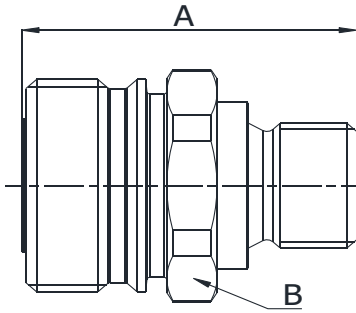

Q04911050A

BSP TERMINATION ENDS
TO ISO 8434-6

SIZE			PART NUMBER	THREAD	DIMENSIONS mm					
DN	Inch	Dash	Male coupling		A	B				
12.5	1/2"	-08	Q04911050A-08-08	1/2" GAS	48	36				

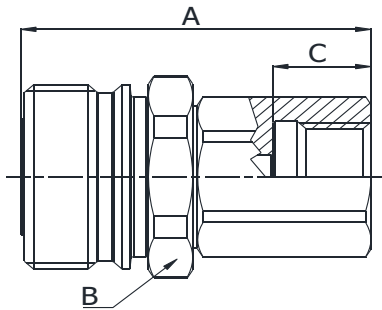

Q04911041A

BSP TERMINATION ENDS
TO DIN 3852 X TYPE

SIZE			PART NUMBER	THREAD	DIMENSIONS mm					
DN	Inch	Dash	Male coupling		A	B	C			
12.5	1/2"	-08	Q04911041A-08-08	1/2" BSP	57	36	16			

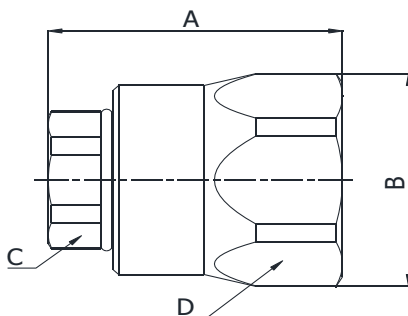

Q05011141A

METRIC TERMINATION ENDS
TO DIN 3852 X TYPE

SIZE			PART NUMBER	THREAD	DIMENSIONS mm					
DN	Inch	Dash	Female coupling		A	B	C	D		
12.5	1/2"	-08	Q05011141A-08-18	M18x1,5	53.5	ø45	27	41		

Q.SAFE
402

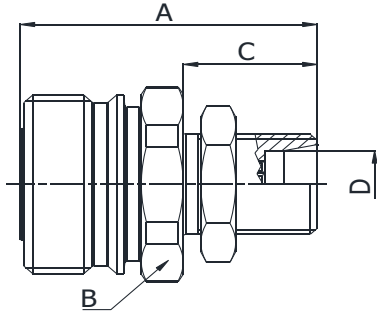

Q04911820A

METRIC TERMINATION ENDS
BULKHEAD

SIZE			PART NUMBER	THREAD	DIMENSIONS mm				
DN	Inch	Dash	Male coupling		A	B	C	D	
12.5	1/2"	-08	Q04911820A-08-20	M20x1,5	51	36	23	ø13,5	

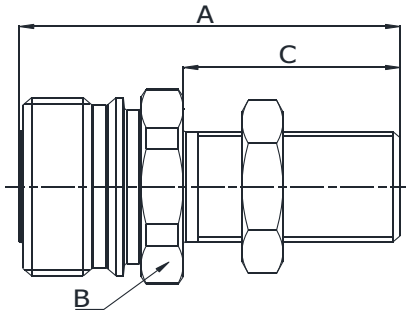

Q04911370A

METRIC TERMINATION ENDS
TO DIN 3863
BULKHEAD

SIZE			PART NUMBER	THREAD	DIMENSIONS mm				
DN	Inch	Dash	Male coupling		A	B	C		
12.5	1/2"	-08	Q04911370A-08-22	M22x1,5	65	36	37		

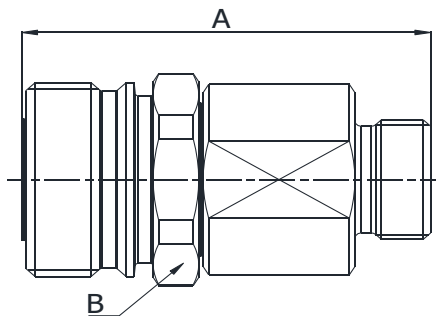

Q04911110A

METRIC TERMINATION ENDS
TO ISO 8434-1
L SERIES

SIZE			PART NUMBER	THREAD	DIMENSIONS mm				
DN	Inch	Dash	Male coupling		A	B			
12.5	1/2"	-08	Q04911110A-08-18	M18x1,5	65	36			
12.5	1/2"	-08	Q04911110A-08-22	M22x1,5	64.7	36			

403 Q.SAFE

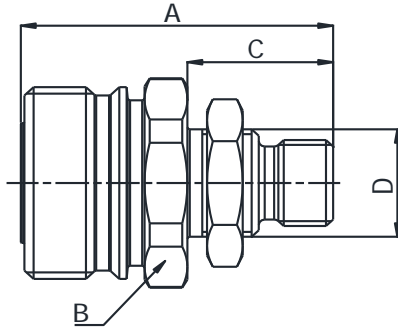

Q04911770A

METRIC TERMINATION END
TO ISO 8434-1
BULKHEAD

SIZE			PART NUMBER	THREAD	DIMENSIONS mm				
DN	Inch	Dash			Male coupling	A	B	C	D
12.5	1/2"	-08	Q04911770A-08-16	M16x1,5	52.5	36	24.5	M20x1.5	
12.5	1/2"	-08	Q04911770A-08-18	M18x1,5	52	36	24	M20x1.5	

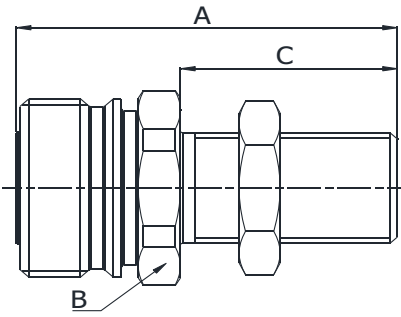

Q04911770A

METRIC TERMINATION END
TO ISO 8434-1
BULKHEAD L SERIES

SIZE			PART NUMBER	THREAD	DIMENSIONS mm				
DN	Inch	Dash			Male coupling	A	B	C	
12.5	1/2"	-08	Q04911770A-08-22	M22x1,5	63	36	35		

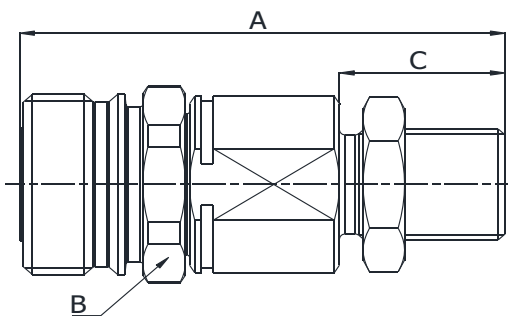

Q04911770B

METRIC TERMINATION END
TO ISO 8434-1
BULKHEAD L SERIES

SIZE			PART NUMBER	THREAD	DIMENSIONS mm				
DN	Inch	Dash			Male coupling	A	B	C	
12.5	1/2"	-08	Q04911770B-08-22	M22x1,5	82	36	28		

Q.SAFE 404

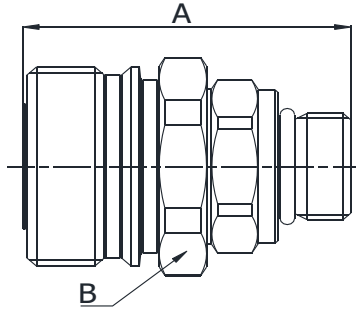

Q04911300A

SAE TERMINATION END
TO SAE J1926-3

SIZE			PART NUMBER	THREAD	DIMENSIONS mm					
DN	Inch	Dash	Male coupling		A	B				
12.5	1/2"	-08	Q04911300A-08-08	3/4"-16 UNF	50	36				

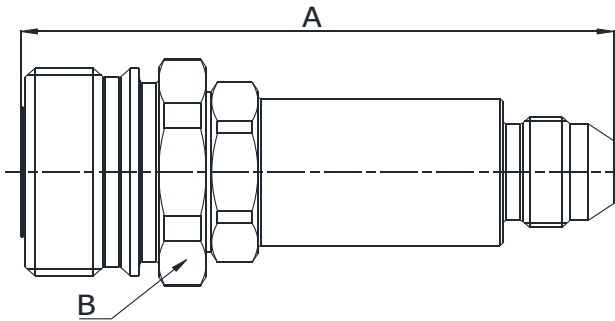

Q04911250A

BSP TERMINATION ENDS
TO ISO 8434-6

SIZE			PART NUMBER	THREAD	DIMENSIONS mm					
DN	Inch	Dash	Male coupling		A	B				
12.5	1/2"	-8	Q04711050A-08-08	1/2"	48	32				

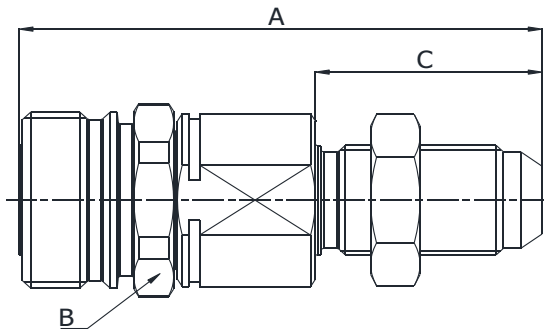

Q04911230A

SAE TERMINATION ENDS
TO ISO 8434-2
BULKHEAD

SIZE			PART NUMBER	THREAD	DIMENSIONS mm					
DN	Inch	Dash	Male coupling		A	B	C			
12.5	1/2"	-08	Q04911230A-08-10	7/8"-14 UNF	94.8	36	40.1			

405 Q.SAFE



DIAGNOSTIC

TECHNICAL DATA

 SIZE			 WORKING PRESSURE (Dynamic)		 MINIMUM BURST PRESSURE	
DN	inch	Dash	MPa	PSI	Male	
					MPa	PSI
5	1/8	02	42	6090	250	36250

PRODUCT DESCRIPTION

- Quick coupling purposely designed to easily access hydraulic systems for performance testing
- Installing male coupling in several parts of the hydraulic system, a reliable diagnosis can be carried out in a short time
- Connection by pushing the male coupling in the female of vice-versa
- Disconnection by pulling back the sleeve
- Retaining by ball latching system
- Shut-off system by flat valve
- Wide range of termination ends available on request and protective cap
- Interchangeability according to ISO 15171-1 and SAE J1502

MATERIAL

Male coupling in steel, with some hardened areas in correspondence to the most stressed points. Carbonitrided valve, spring in C98 steel and seals in NBR (other materials on request)

WORKING TEMPERATURE

-22°F up to +230°F (-30°C up to +110°C)
For different temperature range, the coupling can be assembled with specific seals

SAFETY FACTOR

4:1 for dynamic pressures

IMPULSE PRESSURES

1,000,000 cycles at 133% of the rated one (freq. 1Hz)

TEST SPECIFICATIONS

ISO 18869

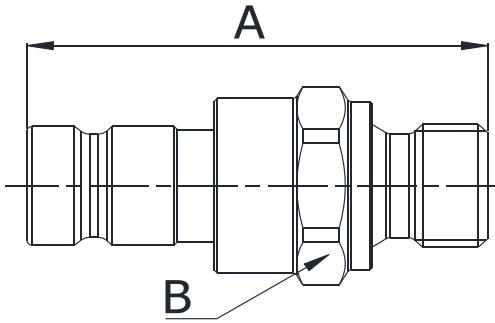

Q04511050A

BSP TERMINATION ENDS
TO ISO 8434-6

SIZE			PART NUMBER	THREAD	DIMENSIONS mm					
DN	Inch	Dash	Male coupling		A	B				
5	1/8"	-02	Q04511050A-02-04	3/8"	43.8	19				

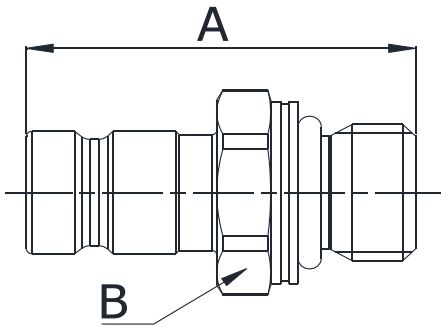

Q04511190A

METRIC TERMINATION ENDS
TO ISO 6149-2

SIZE			PART NUMBER	THREAD	DIMENSIONS mm					
DN	Inch	Dash	Male coupling		A	B				
5	1/8"	-02	Q04511190A-02-14	M14x1,5	36.4	19				

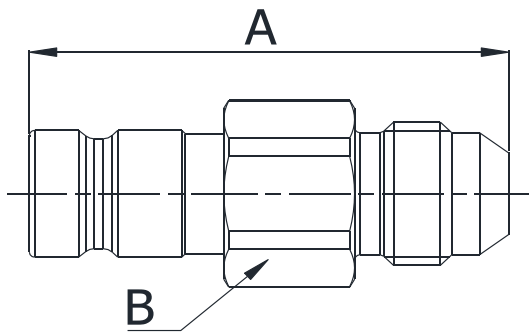

Q04511250A

SAE TERMINATION ENDS
TO ISO 8434-2

SIZE			PART NUMBER	THREAD	DIMENSIONS mm					
DN	Inch	Dash	Male coupling		A	B				
5	1/8"	-02	Q04511250A-02-06	3/8"	43.9	17				

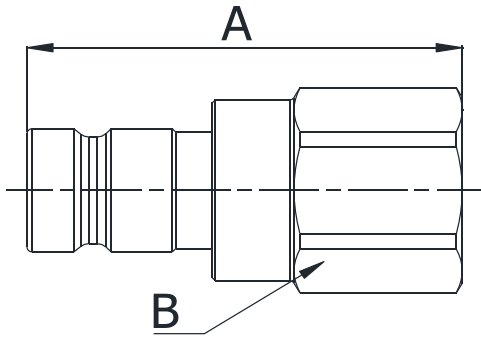

Q04511251A

SAE TERMINATION ENDS
TO ISO 8434-2

SIZE			PART NUMBER	THREAD	DIMENSIONS mm					
DN	Inch	Dash	Male coupling		A	B				
5	1/8"	-02	Q04511251A-02-06	3/8"	41.8	19				

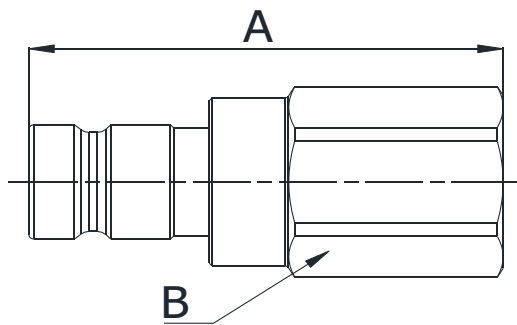

Q04511301A

SAE TERMINATION ENDS
TO SAE J1926-1

SIZE			PART NUMBER	THREAD	DIMENSIONS mm					
DN	Inch	Dash	Male coupling		A	B				
5	1/8"	-02	Q04511301A-02-06	9/16"-18 UNF	46.8	19				

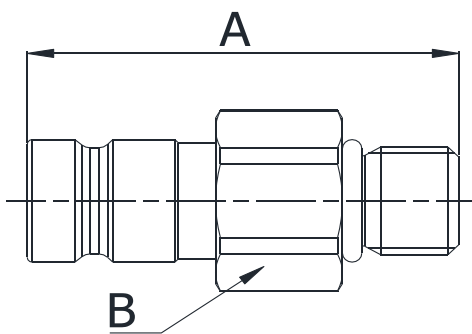

Q04511320A

SAE TERMINATION ENDS
TO SAE J1926-2

SIZE			PART NUMBER	THREAD	DIMENSIONS mm					
DN	Inch	Dash	Male coupling		A	B				
5	1/8"	-02	Q04511320A-02-04	7/16"-20 UNF	40.8	17				
5	1/8"	-02	Q04511320A-02-06	9/16"-18 UNF	37.4	17				

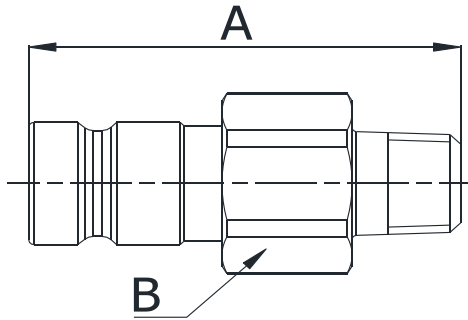

Q04511280A

NPTF TERMINATION ENDS
TO ANSI B 1.20.3

SIZE			PART NUMBER	THREAD	DIMENSIONS mm				
DN	Inch	Dash			Male coupling	A	B		
5	1/8"	-02	Q04511280A-02-02	1/8" NPTF	39.8	17			
5	1/8"	-02	Q04511280A-02-04	1/4" NPTF	44.3	17			
5	1/8"	-02	Q04511280A-02-06	3/8" NPTF	39.9	19			

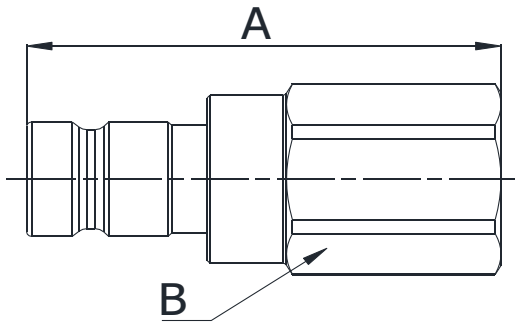

Q04511341A

NPTF TERMINATION ENDS
TO ANSI B 1.20.3

SIZE			PART NUMBER	THREAD	DIMENSIONS mm				
DN	Inch	Dash			Male coupling	A	B		
5	1/8"	-02	Q04511341A-02-02	1/8" NPTF	37.8	17			
5	1/8"	-02	Q04511341A-02-04	1/4" NPTF	45.8	17			

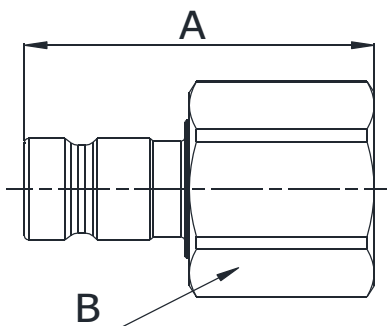

Q04511241A

ORFS TERMINATION ENDS
TO SAE J1453

SIZE			PART NUMBER	THREAD	DIMENSIONS mm				
DN	Inch	Dash			Male coupling	A	B		
5	1/8"	-02	Q04511241A-02-08	13/16"-16 UN	38.8	24			

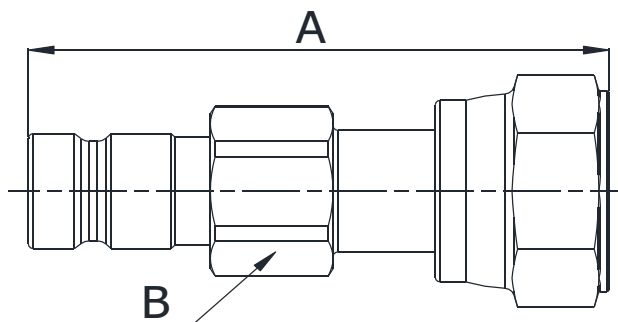

Q04511241A

ORFS TERMINATION ENDS
TO SAE J1453

SIZE			PART NUMBER	THREAD	DIMENSIONS mm					
DN	Inch	Dash	Male coupling		A	B				
5	1/8"	-02	Q04511241A-02-04	9/16"-16 UNF	53	17				
5	1/8"	-02	Q04511241A-02-06	11/16"-16 UN	56.8	17				

Q.SAFE
410

FLAT FACE



Pressure Drop

Pressure Drop

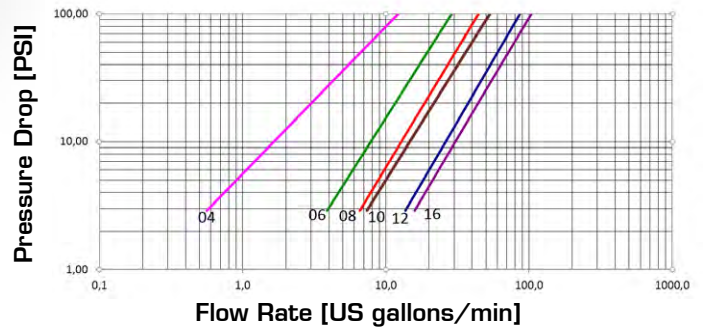
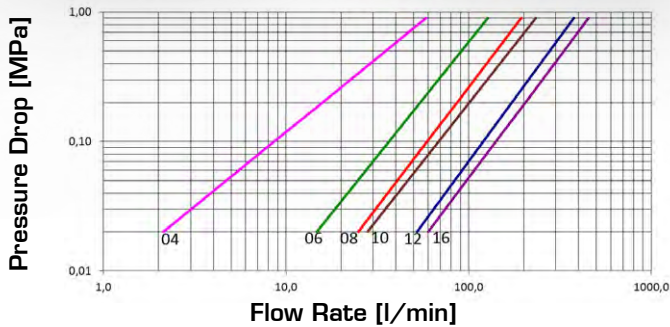

TECHNICAL DATA

SIZE			MPa				FLOW RATE		N		Oil Spillage Connection/Disconnection		MINIMUM BURST PRESSURE						CONNECTION WITH FEMALE UNDER PRESSURE (MALE AT 0 MPa)
DN	inch	Dash	MPa	PSI	MPa	PSI	l/min	US GPM	N	lb.	cc.	cubic inch	Male		Female		M & F		
			MPa	PSI	MPa	PSI							MPa	PSI	MPa	PSI	MPa	PSI	
6.3	1/4"	04	35	5075	32	4640	16	4.2	120	27.0	0.005	0.0003	180	26100	130	18850	160	23200	Allowed up to 6 MPa
10	3/8"	06	35	5075	25	3625	54	14.3	130	29.2	0.007	0.0004	135	19575	125	18125	140	20300	Allowed up to 6 MPa
12.5	1/2"	08	35	5075	25	3625	86	22.7	150	33.7	0.008	0.0005	120	17400	110	15950	145	21025	Allowed up to 4 MPa
16	5/8"	10	35	5075	25	3625	101	26.7	160	36.0	0.008	0.0005	150	21750	100	14500	160	23200	Allowed up to 3 MPa
19	3/4"	12	35	5075	25	3625	172	45.4	210	47.2	0.009	0.0005	100	14500	105	15225	140	20300	Allowed up to 2 MPa
25	1"	16	35	5075	21	3045	204	53.9	210	47.2	0.02	0.0012	105	15225	85	12325	145	21025	Allowed up to 2 MPa

Connection with Male under pressure not allowed; Disconnection under pressure not allowed
 The rated flow represents the normal operating condition. The maximum recommended flow rate is equal to 1.5 times the rated flow

PRODUCT DESCRIPTION

- Flat mating surfaces easily wiped clean to prevent contamination and spillage during connection/disconnection
- Connection is made by pushing the male coupling and disconnection by pulling back the sleeve of the female
- Safety system on female part to prevent accidental disconnection
- Positive, quick connection of the male into the female by the latching ball system
- Shut-off by flat valve
- Interchangeability according to ISO 16028 and HTMA standards (only for 3/8")
- 1,000,000 cycles at 120% of rated (freq. 1Hz - connected conditions)

MATERIAL

Female and male coupling in steel, with some stressed tempered or carbonitrided areas. Springs in AISI and C98 steel, seals in polyurethane and NBR. Other materials (VITON, EPDM or any others) on request

WORKING TEMPERATURE

-22°F up to +230°F (-30°C up to +110°C)
 For other temperatures the coupling is assembled with the specified seals

SAFETY FACTOR

4:1 for dynamic pressures

IMPULSE PRESSURES

100,000 cycles at 133% of the rated one (freq. 1Hz) in disconnected conditions. 1,000,000 cycles at 120% of rated one (freq. 1Hz) in connected conditions.

TEST SPECIFICATIONS

ISO 18869

Q04111040A Q03911040A

BSP TERMINATION ENDS
TO ISO 8434-6
BULKHEAD

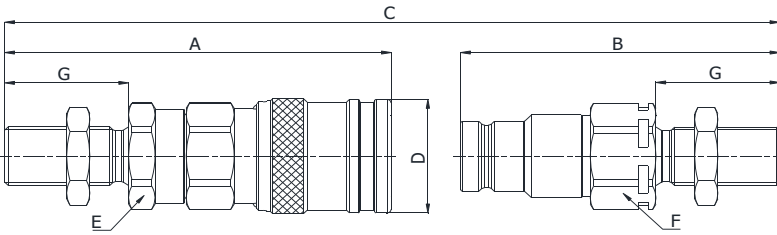

SIZE			PART NUMBER		THREAD	DIMENSIONS mm						
DN	Inch	Dash	Female coupling	Male coupling		A	B	C	D	E	F	G
10	3/8"	-06	Q04111040A-06-06	Q03911040A-06-06	3/8"	99.9	82.5	A+B-16,4	ø32	27	27	32

Q04111041A Q03911041A

BSP TERMINATION ENDS
TO DIN 3852 X TYPE

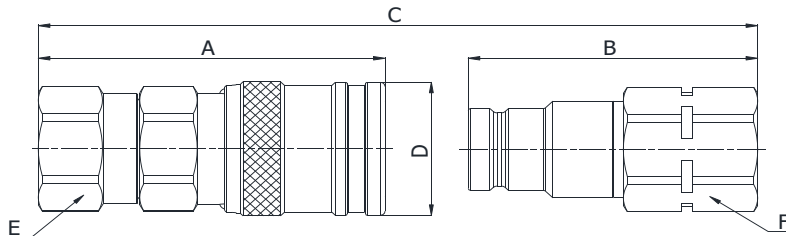

SIZE			PART NUMBER		THREAD	DIMENSIONS mm							
DN	Inch	Dash	Female coupling	Male coupling		A	B	C	D	E	F		
6.3	1/4"	-04	Q04111041A-04-04	Q03911041A-04-04	1/4"	63.6	52.1	A+B-11,1	ø28	24	22		
6.3	1/4"	-04	Q04111041A-04-06	Q03911041A-04-06	3/8"	63.6	53.6	A+B-11,1	ø28	24	22		
10	3/8"	-06	Q04111041A-06-06	Q03911041A-06-06	3/8"	74.9	62.5	A+B-15,9	ø32	27	27		
10	3/8"	-06	Q04111041A-06-08	Q03911041A-06-08	1/2"	77.9	65.5	A+B-15,9	ø32	27	27		
12.5	1/2"	-08	Q04111041A-08-06	Q03911041A-08-06	3/8"	81.7	72.5	A+B-17,1	ø38	34	34		
12.5	1/2"	-08	Q04111041A-08-08	Q03911041A-08-08	1/2"	84.7	72.5	A+B-17,1	ø38	34	34		
12.5	1/2"	-08	Q04111041A-08-12	Q03911041A-08-12	3/4"	86.7	74.5	A+B-17,1	ø38	34	34		
16	5/8"	-10	Q04111041A-10-12	Q03911041A-10-12	3/4"	89.9	75.1	A+B-17,6	ø42	34	34		
20	3/4"	-12	Q04111041A-12-08	Q03911041A-12-08	1/2"	105.9	88.5	A+B-21,7	ø48	41	41		
20	3/4"	-12	Q04111041A-12-12	Q03911041A-12-12	3/4"	105.9	88.5	A+B-21,7	ø48	41	41		
20	3/4"	-12	Q04111041A-12-16	Q03911041A-12-16	1"	108.9	91.5	A+B-21,7	ø48	41	41		
25	1"	-16	Q04111041A-16-16	Q03911041A-16-16	1"	114.5	89.8	A+B-22,9	ø55	50	50		
25	1"	-16	Q04111041A-16-20	Q03911041A-16-20	1.1/4"	117	94.8	A+B-22,9	ø55	50	50		

Q04111050A Q03911050A

BSP TERMINATION ENDS
TO ISO 8434-6

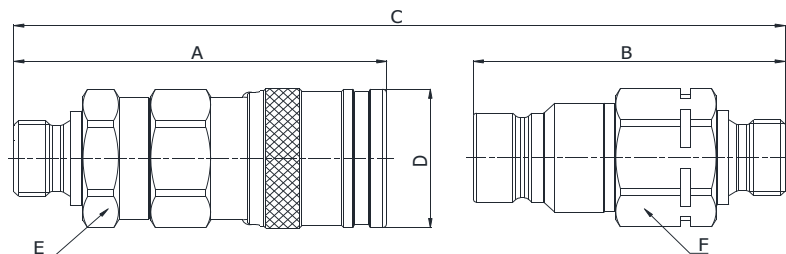

SIZE			PART NUMBER		THREAD	DIMENSIONS mm							
DN	Inch	Dash	Female coupling	Male coupling		A	B	C	D	E	F		
10	3/8"	-06	Q04111050A-06-06	Q03911050A-06-06	3/8"	82.6	65.2	A+B-15,9	ø32	27	27		
10	3/8"	-06	Q04111050A-06-08	Q03911050A-06-08	1/2"	85.1	67.7	A+B-15,9	ø32	27	27		
12.5	1/2"	-08	Q04111050A-08-08	Q03911050A-08-08	1/2"	92.9	77.7	A+B-17,1	ø38	34	34		
12.5	1/2"	-08	Q04111050A-08-12	Q03911050A-08-12	3/4"	94.9	79.7	A+B-17,1	ø38	34	34		
16	5/8"	-10	Q04111050A-10-12	Q03911050A-10-12	3/4"	95.6	80.3	A+B-17,6	ø42	34	34		

Q04111141A Q03911141A

METRIC TERMINATION ENDS
TO ISO 3852-1 X TYPE

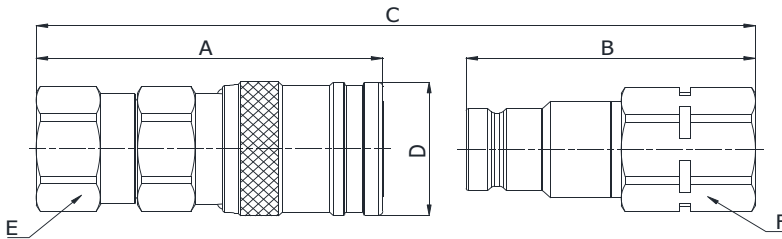

SIZE			PART NUMBER		THREAD	DIMENSIONS mm							
DN	Inch	Dash	Female coupling	Male coupling		A	B	C	D	E	F		
6.3	1/4"	-04	Q04111141A-04-16	Q03911141A-04-16	M16x1,5	63.6	53.6	A+B-11,1	ø28	24	22		
10	3/8"	-06	Q04111141A-06-18	Q03911141A-06-18	M18x1,5	77.9	62.5	A+B-15,9	ø32	27	27		
10	3/8"	-06	Q04111141A-06-22	Q03911141A-06-22	M22x1,5	77.9	64.5	A+B-15,9	ø32	27	27		

Q04111120A Q03911120A

METRIC TERMINATION END
TO ISO 8434-1
S SERIES

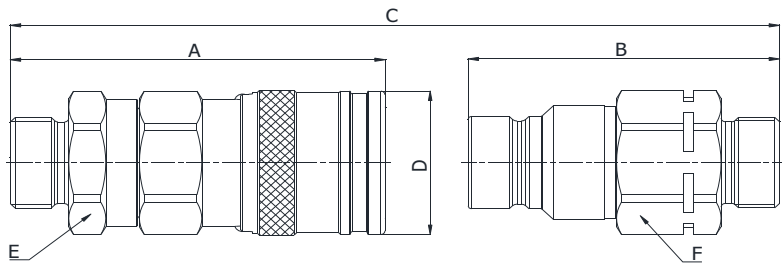

SIZE			PART NUMBER		THREAD	DIMENSIONS mm							
DN	Inch	Dash	Female coupling	Male coupling		A	B	C	D	E	F		
6.3	1/4"	-04	Q04111120A-04-16	Q03911120A-04-16	M16x1,5	69.6	51.1	A+B-11,1	ø28	24	22		
6.3	1/4"	-04	Q04111120A-04-18	Q03911120A-04-18	M18x1,5	69.6	51.1	A+B-11,1	ø28	24	22		
10	3/8"	-06	Q04111120A-06-18	Q03911120A-06-18	M18x1,5	79.9	62.5	A+B-15,9	ø32	27	27		
10	3/8"	-06	Q04111120A-06-20	Q03911120A-06-20	M20x1,5	79.9	62.5	A+B-15,9	ø32	27	27		
12.5	1/2"	-08	Q04111120A-08-20	Q03911120A-08-20	M20x1,5	87.7	72.5	A+B-17,1	ø38	34	34		
12.5	1/2"	-08	Q04111120A-08-24	Q03911120A-08-24	M24x1,5	87.7	74.5	A+B-17,1	ø38	34	34		
20	3/4"	-12	Q04111120A-12-30	Q03911120A-12-30	M30x2	105.9	90.5	A+B-21,7	ø48	41	41		

Q04111191A Q03911191A

METRIC TERMINATION ENDS
TO ISO 6149-1

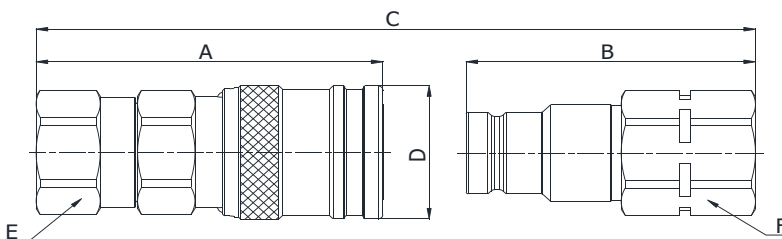

SIZE			PART NUMBER		THREAD	DIMENSIONS mm							
DN	Inch	Dash	Female coupling	Male coupling		A	B	C	D	E	F		
10	3/8"	-06	Q04111191A-06-16	Q03911191A-06-16	M16x1,5	75.4	63	A+B-15,9	ø32	27	27		
10	3/8"	-06	Q04111191A-06-18	Q03911191A-06-18	M18x1,5	76.9	64.5	A+B-15,9	ø32	27	27		

413 Q.SAFE

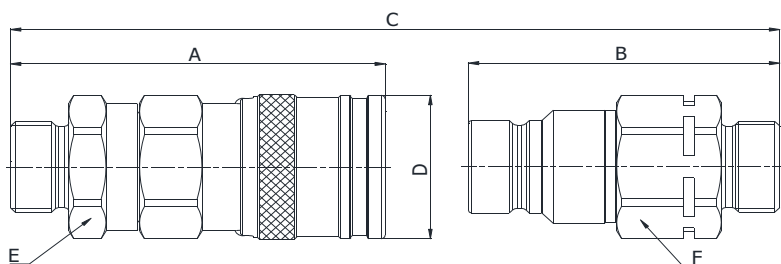

Q0411110A Q0391110A

METRIC TERMINATION END
TO ISO 8434-1
L SERIES

SIZE			PART NUMBER		THREAD	DIMENSIONS mm							
DN	Inch	Dash	Female coupling	Male coupling		A	B	C	D	E	F		
6.3	1/4"	-04	Q0411110A-04-12	Q0391110A-04-12	M16x1,5	68.6	50.1	A+B-11,1	ø28	24	22		
6.3	1/4"	-04	Q0411110A-04-14	Q0391110A-04-14	M14x1,5	68.6	50.1	A+B-11,1	ø28	24	22		
6.3	1/4"	-04	Q0411110A-04-16	Q0391110A-04-16	M16x1,5	68.6	50.1	A+B-11,1	ø28	24	22		
10	3/8"	-06	Q0411110A-06-14	Q0391110A-06-14	M14x1,5	77.9	61.5	A+B-15,9	ø32	27	27		
10	3/8"	-06	Q0411110A-06-16	Q0391110A-06-16	M16x1,5	78.9	62.5	A+B-15,9	ø32	27	27		
10	3/8"	-06	Q0411110A-06-18	Q0391110A-06-18	M18x1,5	78.9	61.5	A+B-15,9	ø32	27	27		
10	3/8"	-06	Q0411110A-06-22	Q0391110A-06-22	M22x1,5	79.9	62.5	A+B-15,9	ø32	27	27		
12.5	1/2"	-08	Q0411110A-08-18	Q0391110A-08-18	M18x1,5	86.7	72.5	A+B-17,1	ø38	34	34		
12.5	1/2"	-08	Q0411110A-08-22	Q0391110A-08-22	M22x1,5	87.7	72.5	A+B-17,1	ø38	34	34		
12.5	1/2"	-08	Q0411110A-08-26	Q0391110A-08-26	M26x1,5	87.7	72.5	A+B-17,1	ø38	34	34		
20	3/4"	-12	Q0411110A-12-26	Q0391110A-12-26	M26x1,5	101.9	86.5	A+B-21,7	ø48	41	41		
20	3/4"	-12	Q0411110A-12-30	Q0391110A-12-30	M30x2	103.9	88.5	A+B-21,7	ø48	41	41		
25	1"	-16	Q0411110A-16-30	Q0391110A-16-30	M30x2	110.5	79.8	A+B-22,9	ø55	50	50		

Q.SAFE
414

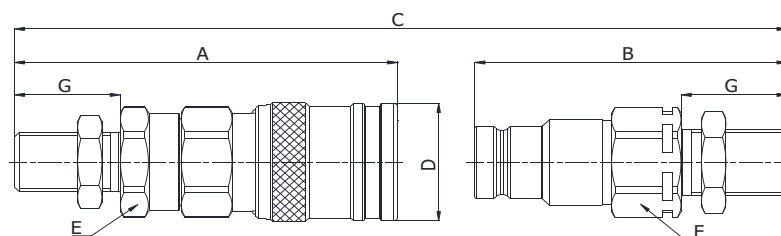

Q04111770B Q03911770B

METRIC TERMINATION END
TO ISO 8434-1
BULKHEAD L SERIES

SIZE			PART NUMBER		THREAD	DIMENSIONS mm						
DN	Inch	Dash	Female coupling	Male coupling		A	B	C	D	E	F	G
6.3	1/4"	-04	Q04111770B-04-12	Q03911770B-04-12	M12x1,5	82.6	65.1	A+B-11,1	ø28	24	22	25
6.3	1/4"	-04	Q04111770B-04-14	Q03911770B-04-14	M14x1,5	82.6	64.1	A+B-11,1	ø28	24	22	25
6.3	1/4"	-04	Q04111770B-04-16	Q03911770B-04-16	M16x1,5	83.6	64.1	A+B-11,1	ø28	24	22	26
10	3/8"	-06	Q04111770B-06-16	Q03911770B-06-16	M16x1,5	93.9	76.5	A+B-15,9	ø32	27	27	26
10	3/8"	-06	Q04111770B-06-18	Q03911770B-06-18	M18x1,5	93.9	76.5	A+B-15,9	ø32	27	27	26
10	3/8"	-06	Q04111770B-06-22	Q03911770B-06-22	M22x1,5	94.9	77.5	A+B-15,9	ø32	27	27	27
12.5	1/2"	-08	Q04111770B-08-18	Q03911770B-08-18	M18x1,5	101.7	86.5	A+B-17,1	ø38	34	34	26
12.5	1/2"	-08	Q04111770B-08-22	Q03911770B-08-22	M22x1,5	102.7	87.5	A+B-17,1	ø38	34	34	27
12.5	1/2"	-08	Q04111770B-08-26	Q03911770B-08-26	M26x1,5	103.7	88.5	A+B-17,1	ø38	34	34	28
20	3/4"	-12	Q04111770B-12-26	Q03911770B-12-26	M26x1,5	114.9	102.5	A+B-21,7	ø48	41	41	29
20	3/4"	-12	Q04111770B-12-30	Q03911770B-12-30	M30x2	118.9	106.5	A+B-21,7	ø48	41	41	32

**Q04111870B
Q03911870B**

METRIC TERMINATION END
TO ISO 8434-1
BULKHEAD S SERIES

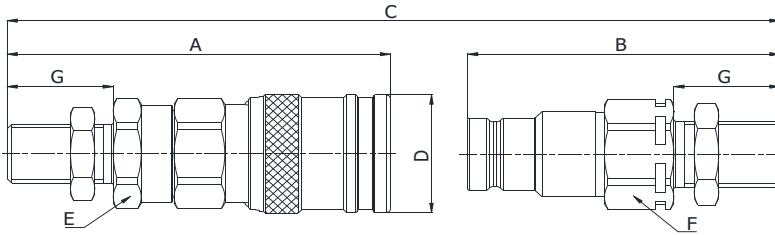

SIZE			PART NUMBER		THREAD	DIMENSIONS mm						
DN	Inch	Dash	Female coupling	Male coupling		A	B	C	D	E	F	G
6.3	1/4"	-04	Q04111870B-04-16	Q03911870B-04-16	M16x1,5	83.6	65.1	A+B-11,1	ø28	24	22	27
6.3	1/4"	-04	Q04111870B-04-18	Q03911870B-04-18	M18x1,5	83.6	65.1	A+B-11,1	ø28	24	22	27
10	3/8"	-06	Q04111870B-06-18	Q03911870B-06-18	M18x1,5	94.9	77.5	A+B-15,9	ø32	27	27	27
10	3/8"	-06	Q04111870B-06-20	Q03911870B-06-20	M20x1,5	94.9	77.5	A+B-15,9	ø32	27	27	27
12.5	1/2"	-08	Q04111870B-08-24	Q03911870B-08-24	M24x1,5	104.7	89.5	A+B-17,1	ø38	34	34	29
20	3/4"	-12	Q04111870B-12-30	Q03911870B-12-30	M30x2	119.9	108.5	A+B-21,7	ø48	41	41	34
25	1"	-16	Q04111870B-16-36	Q03911870B-16-36	M36x2	128.5	101.8	A+B-22,9	ø55	50	50	36

**Q04111341A
Q03911341A**

NPTF TERMINATION END
TO ANSI B 1.20.3

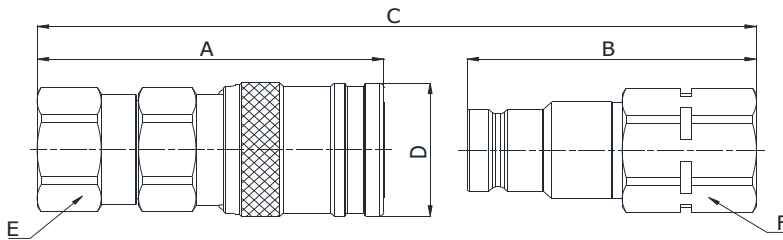

SIZE			PART NUMBER		THREAD	DIMENSIONS mm							
DN	Inch	Dash	Female coupling	Male coupling		A	B	C	D	E	F		
6.3	1/4"	-04	Q04111341A-04-04	Q03911341A-04-04	1/4" NPTF	63.6	52.1	A+B-11,1	ø28	24	22		
10	3/8"	-06	Q04111341A-06-06	Q03911341A-06-06	3/8" NPTF	74.9	62.5	A+B-15,9	ø32	27	27		
10	3/8"	-06	Q04111341A-06-08	Q03911341A-06-08	1/2" NPTF	77.9	65.5	A+B-15,9	ø32	27	27		
12.5	1/2"	-08	Q04111341A-08-08	Q03911341A-08-08	1/2" NPTF	84.7	72.5	A+B-17,1	ø38	34	34		
12.5	1/2"	-08	Q04111341A-08-12	Q03911341A-08-12	3/4" NPTF	86.7	74.5	A+B-17,1	ø38	34	34		
16	5/8"	-10	Q04111341A-10-08	Q03911341A-10-08	1/2" NPTF	87.9	73.1	A+B-17,6	ø42	34	34		
16	5/8"	-10	Q04111341A-10-12	Q03911341A-10-12	3/4" NPTF	89.9	75.1	A+B-17,6	ø42	34	34		
20	3/4"	-12	Q04111341A-12-12	Q03911341A-12-12	3/4" NPTF	105.9	88.5	A+B-21,7	ø48	41	41		
20	3/4"	-12	Q04111341A-12-16	Q03911341A-12-16	1" NPTF	108.9	91.5	A+B-21,7	ø48	41	41		
25	1"	-16	Q04111341A-16-16	Q03911341A-16-16	1" NPTF	114.5	89.8	A+B-22,9	ø55	50	50		
25	1"	-16	Q04111341A-16-20	Q03911341A-16-20	1.1/4" NPTF	116.6	94.8	A+B-23,3	ø55	50	50		

415 Q.SAFE

Q04111230A Q03911230A

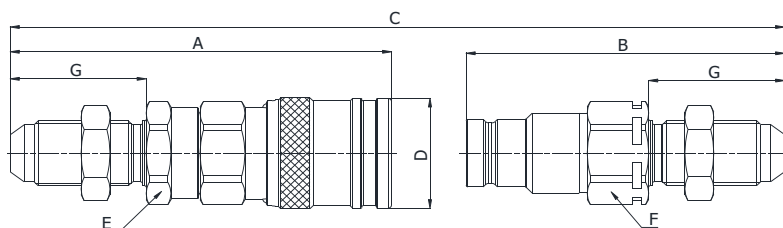

SAE TERMINATION END
TO ISO 8434-2
BULKHEAD

SIZE			PART NUMBER		THREAD	DIMENSIONS mm						
DN	Inch	Dash	Female coupling	Male coupling		A	B	C	D	E	F	G
10	3/8"	-06	Q04111230A-06-08	Q03911230A-06-08	3/4"-16 UNF	105.5	88.1	A+B-15,9	ø32	27	27	36.6
10	3/8"	-06	Q04111230A-06-10	Q03911230A-06-10	7/8"-14 UNF	109	91.6	A+B-15,9	ø32	27	27	40.1
12.5	1/2"	-08	Q04111230A-08-10	Q03911230A-08-10	7/8"-14 UNF	116.8	101.6	A+B-17,1	ø38	34	34	40.1
12.5	1/2"	-08	Q04111230A-08-12	Q03911230A-08-12	1.1/16"-12 UN	121.1	105.9	A+B-17,1	ø38	34	34	44.4

Q.SAFE 416

Q04111301A Q03911301A

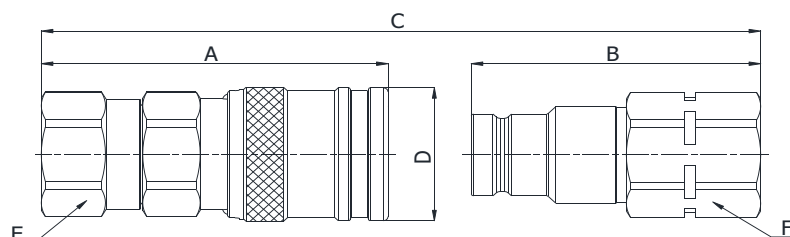

SAE TERMINATION END
TO SAE J1926-1

SIZE			PART NUMBER		THREAD	DIMENSIONS mm							
DN	Inch	Dash	Female coupling	Male coupling		A	B	C	D	E	F		
6.3	1/4"	-04	Q04111301A-04-06	Q03911301A-04-06	9/16"-18 UNF	63.6	53.6	A+B-11,1	ø28	24	22		
10	3/8"	-06	Q04111301A-06-06	Q03911301A-06-06	9/16"-18 UNF	75.4	63	A+B-15,9	ø32	27	27		
10	3/8"	-06	Q04111301A-06-08	Q03911301A-06-08	3/4"-16 UNF	77.4	65	A+B-15,9	ø32	27	27		
10	3/8"	-06	Q04111301A-06-10	Q03911301A-06-10	7/8"-14 UNF	79.9	67.5	A+B-15,9	ø32	27	27		
12.5	1/2"	-08	Q04111301A-08-08	Q03911301A-08-08	3/4"-16 UNF	84.2	72	A+B-17,1	ø38	34	34		
12.5	1/2"	-08	Q04111301A-08-10	Q03911301A-08-10	7/8"-14 UNF	86.7	74.5	A+B-17,1	ø38	34	34		
12.5	1/2"	-08	Q04111301A-08-12	Q03911301A-08-12	1.1/16"-12 UN	89.7	77.5	A+B-17,1	ø38	34	34		
16	5/8"	-10	Q04111301A-10-08	Q03911301A-10-08	3/4"-16 UNF	87.4	72.6	A+B-17,6	ø42	34	34		
16	5/8"	-10	Q04111301A-10-10	Q03911301A-10-10	7/8"-14 UNF	89.9	75.1	A+B-17,6	ø42	34	34		
16	5/8"	-10	Q04111301A-10-12	Q03911301A-10-12	1.1/16"-12 UN	92.9	78.1	A+B-17,6	ø42	34	34		
20	3/4"	-12	Q04111301A-12-12	Q03911301A-12-12	1.1/16"-12 UN	108.9	91.5	A+B-21,7	ø48	41	41		
20	3/4"	-12	Q04111301A-12-16	Q03911301A-12-16	1.5/16"-12 UN	108.9	91.5	A+B-21,7	ø48	41	41		
25	1"	-16	Q04111301A-16-16	Q03911301A-16-16	1.5/16"-12 UN	114.5	89.8	A+B-22,9	ø55	50	50		

**Q04111301B
Q03911301B**

SAE TERMINATION END
TO SAE J1926-1

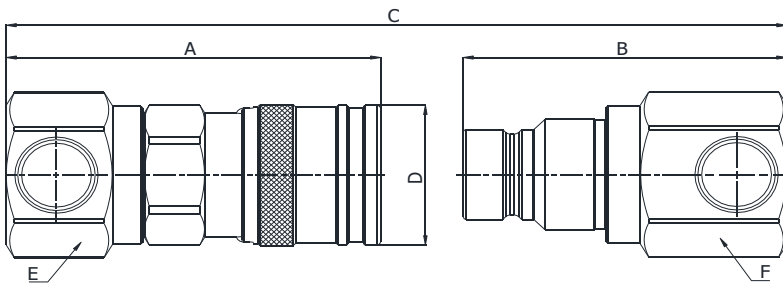

SIZE			PART NUMBER		THREAD	DIMENSIONS mm							
DN	Inch	Dash	Female coupling	Male coupling		A	B	C	D	E	F		
10	3/8"	-06	Q04111301B-06-06	Q03911301B-06-06	9/16"-18 UNF	84.9	72.5	A+B-15,9	ø32	34	34		
12.5	1/2"	-08	Q04111301B-08-08	Q03911301B-08-08	3/4"-16 UNF	93.2	80.5	A+B-17,1	ø38	41	41		

**Q04111270A
Q03911270A**

ORFS TERMINATION ENDS
TO ISO 8434-3
BULKHEAD

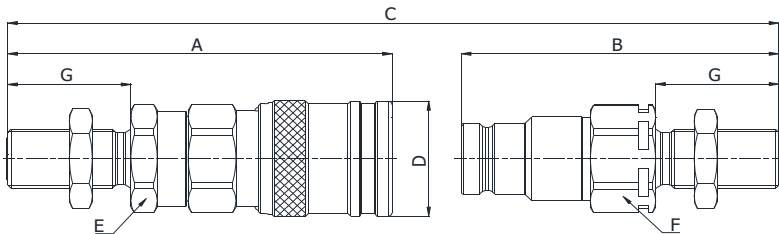

SIZE			PART NUMBER		THREAD	DIMENSIONS mm							
DN	Inch	Dash	Female coupling	Male coupling		A	B	C	D	E	F	G	H
10	3/8"	-06	Q04111270A-06-08	Q03911270A-06-08	13/16"-16 UN	104.4	87	A+B-16,4	ø32	27	27	36.5	36.5

FLAT FACE HIGH PRESSURE



Pressure Drop

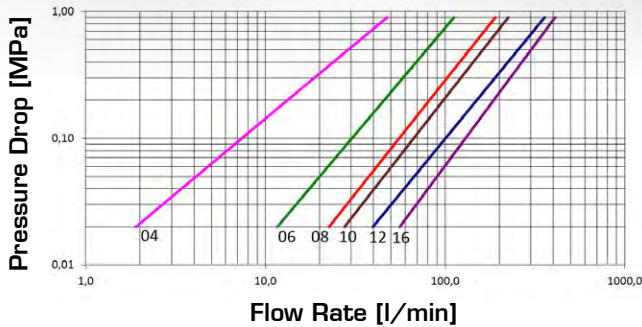

Pressure Drop

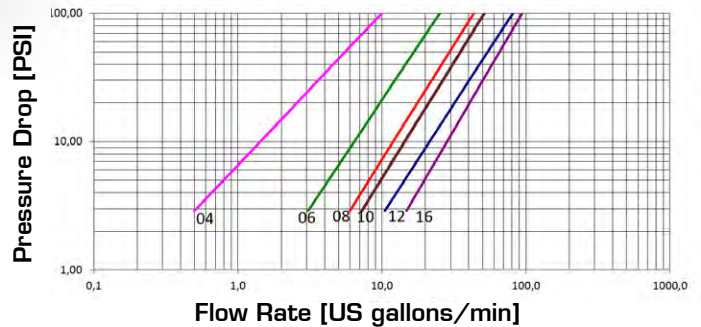

TECHNICAL DATA

SIZE		MPa		FLOW RATE		N		OIL SPILLAGE		MINIMUM BURST PRESSURE						CONNECTION WITH FEMALE UNDER PRESSURE [MALE AT 0 MPa]			
DN	inch	Dash	MPa	PSI	MPa	PSI	l/min	US GPM	N	lb.	cc.	cubic inch	Male		Female		M & F		
													MPa	PSI	MPa	PSI	MPa	PSI	
6.3	1/4	04	35	5075	35	5075	13	3.4	120	27.0	0.005	0.0003	180	26100	150	21750	190	27550	Allowed up to 6 MPa
10	3/8	06	35	5075	35	5075	46	12.2	130	29.2	0.007	0.0004	170	24650	140	20300	170	24650	Allowed up to 6 MPa
12.5	1/2	08	35	5075	35	5075	82	21.7	150	33.7	0.008	0.0005	160	23200	150	21750	170	24650	Allowed up to 4 MPa
16	5/8	10	35	5075	35	5075	98	25.9	160	36.0	0.008	0.0005	170	24650	150	21750	170	24650	Allowed up to 3 MPa
19	3/4	12	35	5075	35	5075	150	39.6	210	47.2	0.009	0.0005	150	21750	150	21750	160	23200	Allowed up to 2 MPa
25	1	16	35	5075	35	5075	186	49.1	210	47.2	0.02	0.0012	160	23200	170	24650	160	23200	Allowed up to 2 MPa

Connection with Male under pressure not allowed; Disconnection under pressure not allowed
 The rated flow represents the normal operating condition. The maximum recommended flow rate is equal to 1.5 times the rated flow

PRODUCT DESCRIPTION

- MQS-FH is the flat-face line for heavy-duty application setting with 35MPa of working pressure in connected and disconnected conditions
- Push connection and pulling back the sleeve for disconnection
- Safety system on female part to prevent accidental disconnection
- Interchangeable with ISO 16028
- 1 Million impulse cycles qualified
- E-Coat 1000 plating

MATERIAL

Female & male couplings in high grade carbon steel with hardened areas in correspondence to the most stressed points. Male vs. female Sealing system in new Polyurethane compound; other seals in NBR with back-up in PTFE.

WORKING TEMPERATURE

-22°F up to +230°F (-30°C up to +110°C)

SAFETY FACTOR

4:1 for dynamic pressures

IMPULSE PRESSURES

1,000,000 cycles at 120% of rated one (freq. 1Hz)

TEST SPECIFICATIONS

ISO 18869

Q04411041A Q04311041A

BSP TERMINATION ENDS
TO DIN 3852 X TYPE

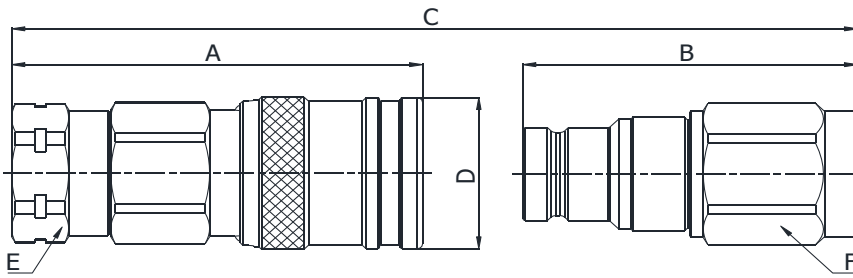

SIZE			PART NUMBER		THREAD	DIMENSIONS mm					
DN	Inch	Dash	Female coupling	Male coupling		A	B	C	D	E	F
6.3	1/4"	-04	Q04411041A-04-04	Q04311041A-04-04	1/4"	65.2	52.4	A+B-11,1	ø28	24	22
10	3/8"	-06	Q04411041A-06-06	Q04311041A-06-06	3/8"	78.3	63.8	A+B-15,9	ø32	27	27
10	3/8"	-06	Q04411041A-06-08	Q04311041A-06-08	1/2"	81.3	67.8	A+B-15,9	ø32	27	27
12.5	1/2"	-08	Q04411041A-08-08	Q04311041A-08-08	1/2"	88.5	71.3	A+B-17,1	ø38	34	34
12.5	1/2"	-08	Q04411041A-08-12	Q04311041A-08-12	3/4"	90.5	75.8	A+B-17,1	ø38	34	34
16	5/8"	-10	Q04411041A-10-12	Q04311041A-10-12	3/4"	94.6	76.4	A+B-17,1	ø42	36	34
20	3/4"	-12	Q04411041A-12-12	Q04311041A-12-12	3/4"	108	89.8	A+B-21,7	ø48	41	41
20	3/4"	-12	Q04411041A-12-16	Q04311041A-12-16	1"	111	92.8	A+B-21,7	ø48	41	41
25	1"	-16	Q04411041A-16-16	Q04311041A-16-16	1"	119.4	92.1	A+B-22,9	ø55	50	50
25	1"	-16	Q04411041A-16-20	Q04311041A-16-20	1.1/4"	122.4	97.1	A+B-22,9	ø55	50	50

Q04411341A Q04311341A

NPTF TERMINATION END
TO ANSI B 1.20.3

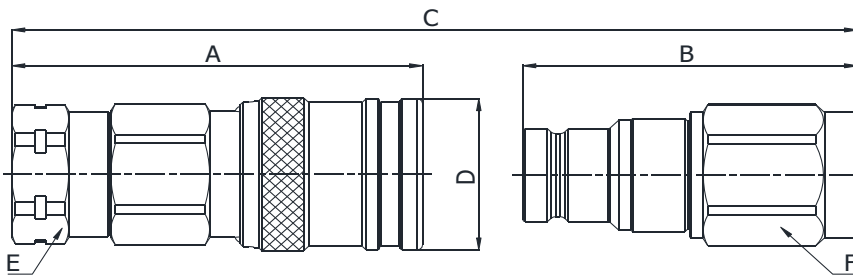

SIZE			PART NUMBER		THREAD	DIMENSIONS mm					
DN	Inch	Dash	Female coupling	Male coupling		A	B	C	D	E	F
10	3/8"	-06	Q04411341A-06-06	Q04311341A-06-06	3/8"-NPT	78.3	63.8	A+B-15,9	ø32	27	27
12.5	1/2"	-08	Q04411341A-08-08	Q04311341A-08-08	1/2"-NPT	88.5	71.3	A+B-17,1	ø38	34	34
20	3/4"	-12	Q04411341A-12-12	Q04311341A-12-12	3/4"-NPT	108	89.8	A+B-21,7	ø48	41	41
25	1"	-16	Q04411341A-16-16	Q04311341A-16-16	1"-NPT	119.4	92.1	A+B-22,9	ø55	50	50

Q0441120A Q0431120A

METRIC TERMINATION ENDS
TO ISO 8434-1 S SERIES

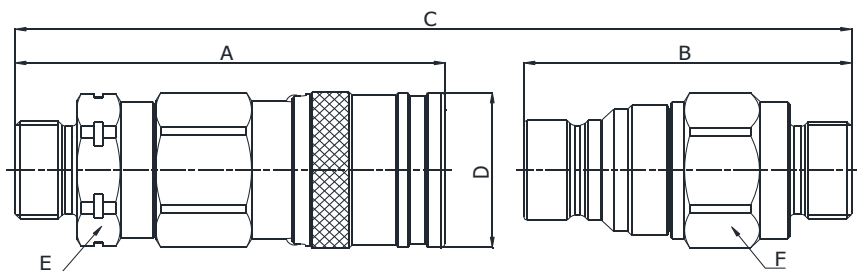

SIZE			PART NUMBER		THREAD	DIMENSIONS mm					
DN	Inch	Dash	Female coupling	Male coupling		A	B	C	D	E	F
12.5	1/2"	-08	Q0441120A-08-24	Q0431120A-08-24	M24x1,5	97.5	74.3	A+B-17,1	ø38	34	34

Q04411870B Q04311870B

METRIC TERMINATION ENDS
TO ISO 8434-1 S SERIES
BULKHEAD

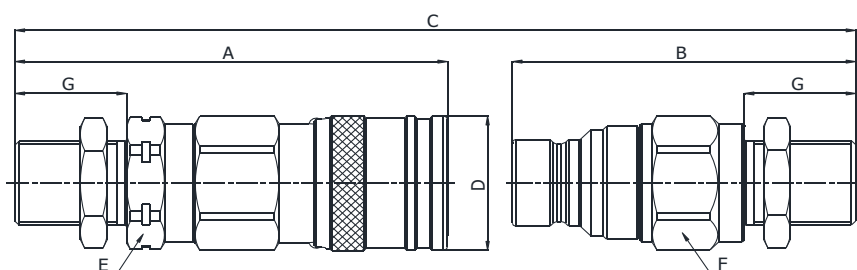

SIZE			PART NUMBER		THREAD	DIMENSIONS mm						
DN	Inch	Dash	Female coupling	Male coupling		A	B	C	D	E	F	G
12.5	1/2"	-08	Q04411870B-08-24	Q04311870B-08-24	M24x1,5	112.5	89.3	A+B-17,1	ø38	34	34	29

Q04411301A Q04311301A

SAE TERMINATION END
TO SAE J1926-1

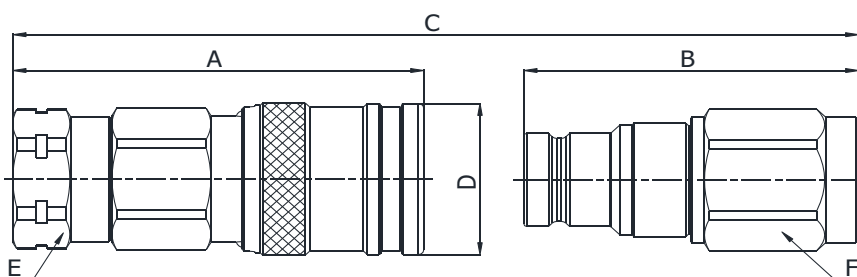

SIZE			PART NUMBER		THREAD	DIMENSIONS mm					
DN	Inch	Dash	Female coupling	Male coupling		A	B	C	D	E	F
10	3/8"	-06	Q04411301A-06-08	Q04311301A-06-08	3/4"-16UNF	80,8	66,8	A+B-15,9	ø32	27	27
12.5	1/2"	-08	Q04411301A-08-10	Q04311301A-08-10	7/8"-14UNF	90.5	74.8	A+B-17,1	ø38	34	34
12.5	1/2"	-08	Q04411301A-08-12	Q04311301A-08-12	1.1/16"-12UNF	93.5	78.8	A+B-17,1	ø38	34	34
20	3/4"	-12	Q04411301A-12-12	Q04311301A-12-12	1.1/16"-12 UN	111	89.8	A+B-21,7	ø48	41	41
20	3/4"	-12	Q04411301A-12-16	Q04311301A-12-16	1.5/16"-12 UN	111	92.8	A+B-21,7	ø48	41	41



FLAT FACE MALE CONNECTABLE UNDER PRESSURE

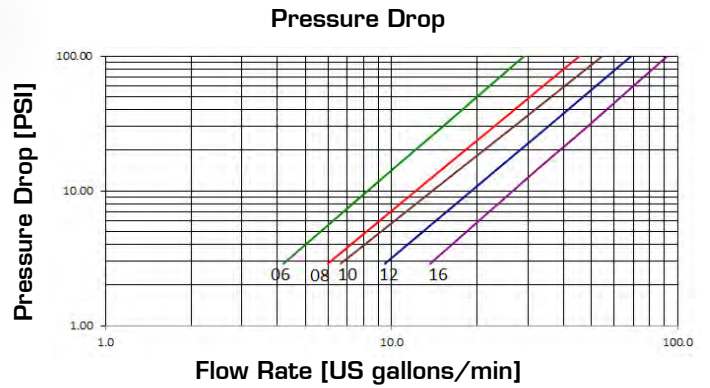
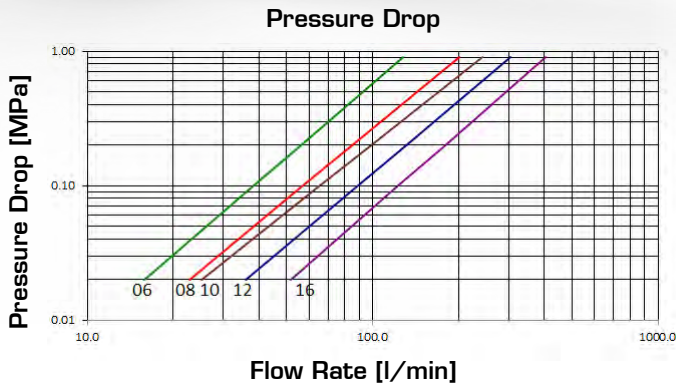

TECHNICAL DATA

SIZE			MPa				FLOW RATE		N		OIL SPILLAGE Connection/Disconnection		MINIMUM BURST PRESSURE				CONNECTION/DISCONNECTION UNDER PRESSURE
DN	inch	Dash	MPa	PSI	MPa	PSI	l/min	US GPM	N	lb.	cc.	cubic inch	Male		M & F		
												MPa	PSI	MPa	PSI		
10	3/8	06	35	5075	35	5075	56	14.8	150	33.7	0.007	0.0004	170	24650	140	20300	Connection allowed
12.5	1/2	08	35	5075	35	5075	85	22.5	180	40.5	0.008	0.0005	170	24650	140	20300	Connection allowed
16	5/8	10	35	5075	35	5075	99	26.2	200	45.0	0.008	0.0005	170	24650	140	20300	Connection allowed
19	3/4	12	35	5075	35	5075	131	34.6	200	45.0	0.009	0.0005	140	20300	150	21750	Connection allowed
25	1	16	35	5075	35	5075	170	44.9	220	49.5	0.02	0.0012	140	23200	160	23200	Connection allowed

The rated flow represents the normal operating condition. The maximum recommended flow rate is equal to 1.5 times the rated flow

PRODUCT DESCRIPTION

- Triple valve system that guarantees connection under pressure (female part always with 0MPa) safely
- Low connection effort during connection under pressure
- Working pressure 35MPa
- Interchangeable according to ISO 16028:1997aMD.1:2006 (E)
- Sealing system with flat valve
- Polyurethane seals
- Compact design
- Wide range of termination ends
- E-Coat 1000 plating

MATERIAL

Couplings in steel with some stressed area hardened, carbonitrided valve, springs in C98 steel, seals in polyurethane and NBR, back-up ring PTFE

WORKING TEMPERATURE

-22°F up to +230°F (-30°C up to +110°C)

SAFETY FACTOR

4:1 for dynamic pressures

IMPULSE PRESSURES

1,000,000 cycles (connected and disconnected conditions) at 120% of the rated one (freq. 1Hz)

TEST SPECIFICATIONS

ISO 18869

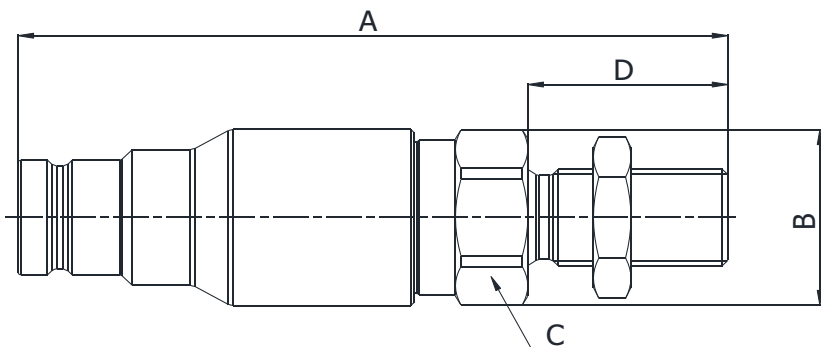

Q04011040A

BSP TERMINATION ENDS
TO ISO 8434-6
BULKHEAD

SIZE			PART NUMBER Male coupling	THREAD	DIMENSIONS mm					
DN	Inch	Dash			A	B	C	D		
10	3/8"	-06	Q04011040A-06-06	3/8"	113.5	ø30	27	32		

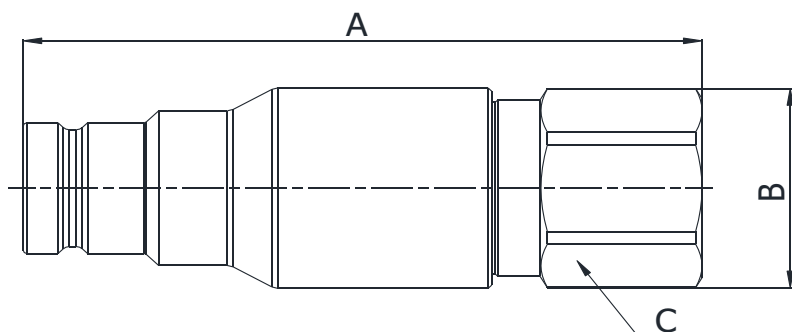

Q04011041A

BSP TERMINATION ENDS
TO DIN 3852 TYPE

SIZE			PART NUMBER Male coupling	THREAD	DIMENSIONS mm					
DN	Inch	Dash			A	B	C			
10	3/8"	-06	Q04011041A-06-06	3/8"	91.7	ø30	27			
10	3/8"	-06	Q04011041A-06-08	1/2"	94	ø30	27			
12	1/2"	-08	Q04011041A-08-06	3/8"	99	ø37	34			
12	1/2"	-08	Q04011041A-08-08	1/2"	99	ø37	34			
12	1/2"	-08	Q04011041A-08-12	3/4"	102	ø37	34			
16	5/8"	-10	Q04011041A-10-12	3/4"	114.3	ø40	36			
19	3/4"	-12	Q04011041A-12-12	3/4"	118	ø45	41			
19	3/4"	-12	Q04011041A-12-16	1"	122	ø45	41			
25	1"	-16	Q04011041A-16-16	1"	126.3	ø55	50			
25	1"	-16	Q04011041A-16-20	1.1/4"	130	ø55	50			

Q.SAFE 422

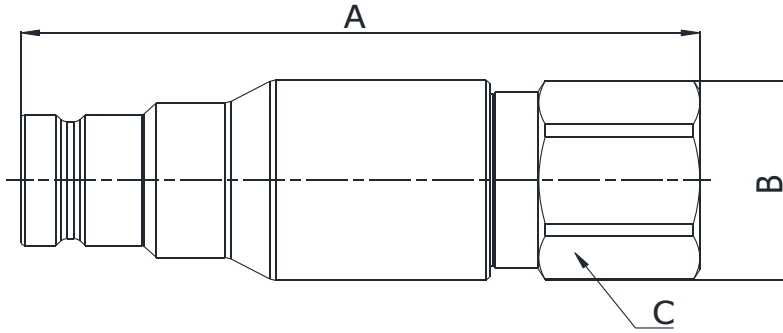

Q04011341A

NPTF TERMINATION END
TO ANSI B 1.20.3

SIZE			PART NUMBER	THREAD	DIMENSIONS mm					
DN	Inch	Dash			Male coupling	A	B	C		
10	3/8"	-06	Q04011341A-06-06	3/8" NPTF	91.7	ø30	27			
10	3/8"	-06	Q04011341A-06-08	1/2" NPTF	94	ø30	27			
12	1/2"	-08	Q04011341A-08-08	1/2" NPTF	98	ø38	34			
12	1/2"	-08	Q04011341A-08-12	3/4" NPTF	100	ø38	34			
16	5/8"	-10	Q04011341A-10-12	3/4" NPTF	114.3	ø40	36			
19	3/4"	-12	Q04011341A-12-12	3/4" NPTF	118	ø45	41			
19	3/4"	-12	Q04011341A-12-16	1" NPTF	122	ø45	41			
25	1"	-16	Q04011341A-16-20	1.1/4" NPTF	130	ø55	50			

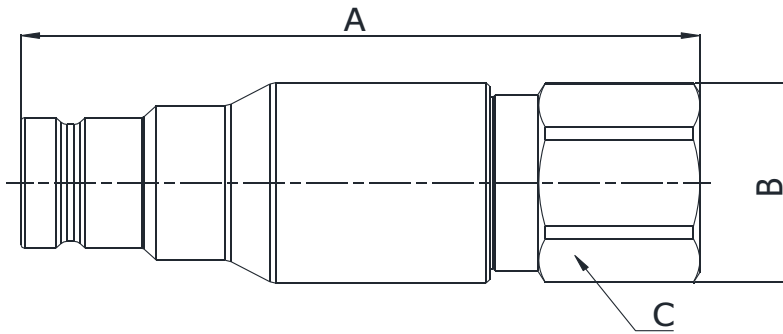

Q04011301A

SAE TERMINATION ENDS
TO SAE J1926-1

SIZE			PART NUMBER	THREAD	DIMENSIONS mm					
DN	Inch	Dash			Male coupling	A	B	C		
10	3/8"	-06	Q04011301A-06-06	9/16"-18 UNF	91.7	ø30	27			
10	3/8"	-06	Q04011301A-06-08	3/4" 16UNF	94.5	ø30	27			
12	1/2"	-08	Q04011301A-08-10	7/8" -14 UNF	102	ø38	34			
12	1/2"	-08	Q04011301A-08-12	1.1/16"-12UN	105	ø38	34			
19	3/4"	-12	Q04011301A-12-16	1.5/16"-12UN	122.1	ø45	41			
25	1"	-16	Q04011301A-16-16	1.5/16"-12 UN	126.3	ø55	50			



FLAT FACE SCREW TYPE

Pressure Drop

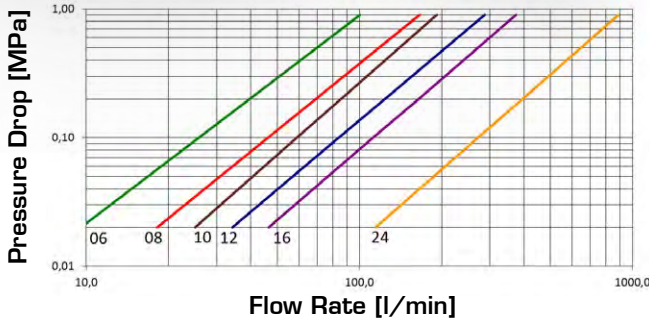

Pressure Drop

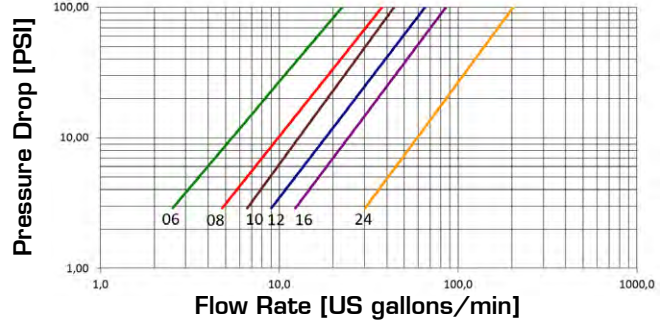

Q.SAFE 424

TECHNICAL DATA

SIZE			WORKING PRESSURE CONNECTED [Dynamic]		WORKING PRESSURE DISCONNECTED [Dynamic]		RATED FLOW at 0.2 MPa of pressure drop		OIL SPILLAGE Connection/ Disconnection		MINIMUM BURST PRESSURE						CONNECTION/ DISCONNECTION UNDER PRESSURE
DN	inch	Dash	MPa	PSI	MPa	PSI	l/min	US GPM	cc.	cubic inch	Male		Female		M & F		
			MPa	PSI	MPa	PSI					MPa	PSI	MPa	PSI	MPa	PSI	
10	3/8	06	42	6090	35	5075	40	10.6	0.007	0.0004	190	27550	145	21025	175	25375	Allowed
12.5	1/2	08	42	6090	35	5075	69	18.2	0.008	0.0005	180	26100	145	21025	170	24650	Allowed
16	5/8	10	42	6090	35	5075	86	22.7	0.008	0.0005	200	29000	145	21025	185	26825	Allowed
19	3/4	12	42	6090	35	5075	124	32.8	0.009	0.0005	145	21025	145	21025	175	25375	Allowed
25	1	16	38	5510	35	5075	165	43.6	0.02	0.0012	145	21025	145	21025	155	22475	Allowed
38	1 1/2	24	32	4640	32	4640	396	104.6	0.05	0.0031	130	18850	130	18850	130	18850	Allowed

The rated flow represents the normal operating condition. The maximum recommended flow rate is equal to 1.5 times the rated flow

PRODUCT DESCRIPTION

- Screw coupling with quick connection system
- Working pressure 35MPa
- Triple valve system that guarantees connection under pressure safely
- Interchangeable according to Manuli Q.Safe specifications
- Sealing system with flat valve
- Polyurethane seals
- Compact design
- Wide range of termination ends
- E-Coat 1000 plating

MATERIAL

Couplings in steel with some stressed area hardened, carbonitrided valve, springs in C98 steel, seals in polyurethane and NBR, back-up ring PTFE

WORKING TEMPERATURE

-22°F up to +230°F (-30°C up to +110°C)

SAFETY FACTOR

4:1 for dynamic pressures

IMPULSE PRESSURES

1,000,000 cycles at 120% of rated one (freq. 1Hz) in connected and disconnected conditions

TEST SPECIFICATIONS

ISO 18869

ASSEMBLY INSTRUCTIONS

RECOMMENDED TIGHTENING TORQUES

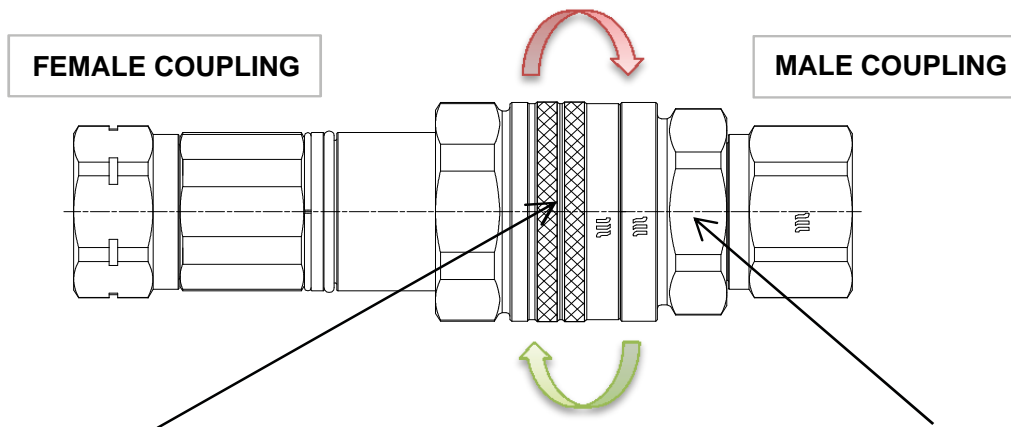

Turn the sleeve on the female applying the tightening torque through the hexagon

Hold the hexagon on the male body with a wrench

SIZE			TIGHTENING TORQUE
DN	Inch	Dash	Nm
10	3/8	06	60
12.5	1/2	08	80
16	5/8	10	100
19	3/4	12	120
25	1	16	200
38	1 1/2	24	400

Q06711041A Q06611041A

BSP TERMINATION ENDS
TO DIN 3852 X TYPE

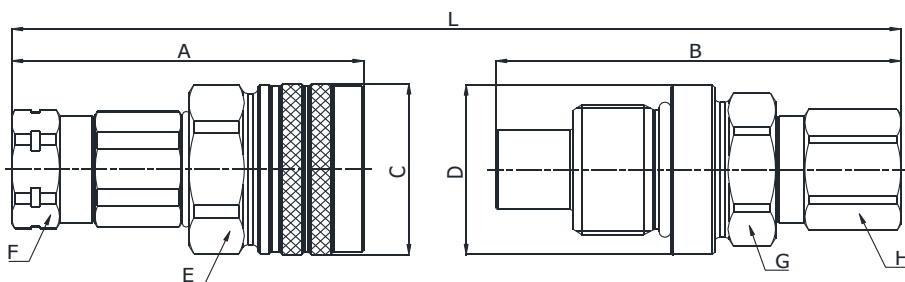

SIZE			PART NUMBER		THREAD	DIMENSIONS mm								
DN	Inch	Dash	Female coupling	Male coupling		A	B	C	D	E	F	G	H	L
10	3/8"	-06	Q06711041A-06-06	Q06611041A-06-06	3/8"	79.7	Ø42,3	91.7	Ø42	38	27	34	27	A+B-17,1
10	3/8"	-06	Q06711041A-06-08	Q06611041A-06-08	1/2"	82.7	Ø42,3	94.5	Ø42	38	27	34	27	A+B-17,1
12.5	1/2"	-08	Q06711041A-08-08	Q06611041A-08-08	1/2"	89.9	Ø50,3	99.0	Ø50	46	34	41	34	A+B-18,4
12.5	1/2"	-08	Q06711041A-08-12	Q06611041A-08-12	3/4"	91.9	Ø50,3	102	Ø50	46	34	41	34	A+B-18,4
16	5/8"	-10	Q06711041A-10-12	Q06611041A-10-12	3/4"	96.5	114.3	Ø55,3	Ø55	50	36	46	36	A+B-18,9
19	3/4"	-12	Q06711041A-12-12	Q06611041A-12-12	3/4"	109,9	118.7	Ø60,3	Ø60	55	41	50	41	A+B-23,5
19	3/4"	-12	Q06711041A-12-16	Q06611041A-12-16	1"	112.9	122.1	Ø60,3	Ø60	55	41	50	41	A+B-23,5
25	1"	-16	Q06711041A-16-16	Q06611041A-16-16	1"	121.3	126.3	Ø70,3	Ø70	65	50	60	50	A+B-24,5
25	1"	-16	Q06711041A-16-20	Q06611041A-16-20	1.1/4"	124.3	130	Ø70,3	Ø70	65	50	60	50	A+B-24,5
38	1 1/2"	-24	Q06711041A-24-24	Q06611041A-24-24	1.1/2"	167,6	166	Ø97,3	Ø97	90	75	85	75	A+B-31

Q.SAFE 426

Q06711341A Q06611341A

NPTF TERMINATION END
TO ANSI B 1.20.3

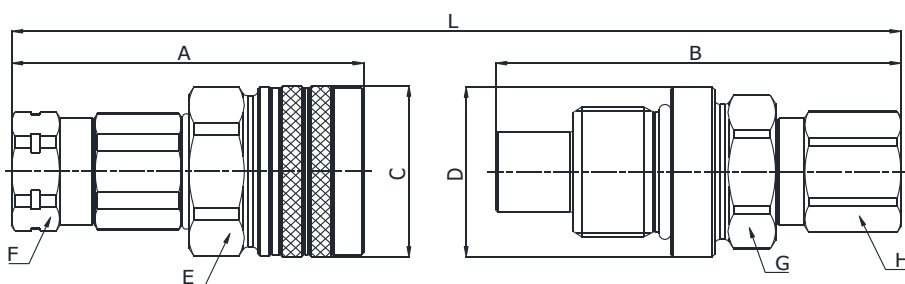

SIZE			PART NUMBER		THREAD	DIMENSIONS mm								
DN	Inch	Dash	Female coupling	Male coupling		A	B	C	D	E	F	G	H	L
10	3/8"	-06	Q06711341A-06-06	Q06611341A-06-06	3/8" NPTF	79.7	Ø42,3	91.7	Ø42	38	27	34	27	A+B-17,1
10	3/8"	-06	Q06711341A-06-08	Q06611341A-06-08	1/2" NPTF	82.7	Ø42,3	94.5	Ø42	38	27	34	27	A+B-17,1
12.5	1/2"	-08	Q06711341A-08-08	Q06611341A-08-08	1/2" NPTF	89.9	Ø50,3	99.0	Ø50	46	34	41	34	A+B-18,4
12.5	1/2"	-08	Q06711341A-08-12	Q06611341A-08-12	3/4" NPTF	91.9	Ø50,3	102	Ø50	46	34	41	34	A+B-18,4
16	5/8"	-10	Q06711341A-10-12	Q06611341A-10-12	3/4" NPTF	96.5	Ø55,3	114.3	Ø55	50	36	46	36	A+B-18,9
19	3/4"	-12	Q06711341A-12-12	Q06611341A-12-12	3/4" NPTF	109.9	Ø60,3	118.7	Ø60	55	41	50	41	A+B-23,5
19	3/4"	-12	Q06711341A-12-16	Q06611341A-12-16	1" NPTF	112.9	Ø60,3	122.1	Ø60	55	41	50	41	A+B-23,5
25	1"	-16	Q06711341A-16-16	Q06611341A-16-16	1" NPTF	121.3	Ø70,3	126.3	Ø70	65	50	60	50	A+B-24,5
25	1"	-16	Q06711341A-16-20	Q06611341A-16-20	1-1/4" NPTF	124.3	Ø70,3	130	Ø70	65	50	60	50	A+B-24,5
38	1-1/2"	-24	Q06711341A-24-24	Q06611341A-24-24	1-1/2" NPTF	167.6	Ø97,3	166	Ø97	90	75	85	75	A+B-31



FLAT FACE FOR MULTICONNECTORS

Pressure Drop

Pressure Drop

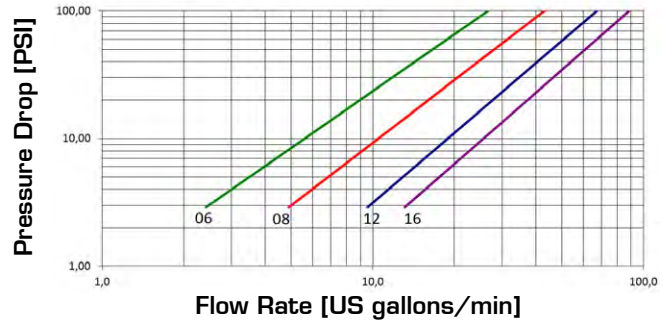
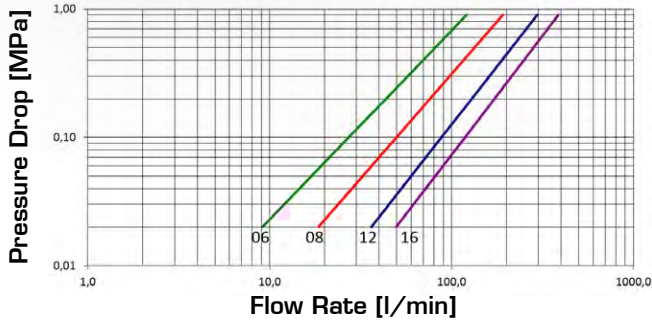

TECHNICAL DATA

SIZE			MPa				FLOW RATE		OIL SPILLAGE Connection/Disconnection		MINIMUM BURST PRESSURE						CONNECTION/DISCONNECTION UNDER PRESSURE
DN	inch	Dash	WORKING PRESSURE CONNECTED (Dynamic)		WORKING PRESSURE DISCONNECTED (Dynamic)		l/min	US GPM	cc.	cubic inch	Male		Female		M & F		Allowed
			MPa	PSI	MPa	PSI					MPa	PSI	MPa	PSI	MPa	PSI	
10	3/8"	06	35	5075	35	5075	44	11.6	0.007	0.0004	170	24650	140	20300	180	26100	Allowed
12.5	1/2"	08	35	5075	35	5075	76	20.1	0.008	0.0005	170	24650	140	20300	180	26100	Allowed
19	3/4"	12	35	5075	35	5075	129	34.1	0.009	0.0005	140	20300	140	20300	160	23200	Allowed
25	1"	16	35	5075	35	5075	172	45.4	0.02	0.0012	160	23200	150	21750	160	23200	Allowed

The rated flow represents the normal operating condition. The maximum recommended flow rate is equal to 1.5 times the rated flow

PRODUCT DESCRIPTION

- Flat face cartridges for multiconnections.
- Working pressure 35 MPa in connected and disconnected conditions.
- Flat mating surfaces easily wiped clean to prevent contamination and spillage during connection/disconnection.
- Shut-off by flat valve
- Polyurethane seals
- 1,000,000 cycles at 120% of rated one (freq. 1Hz – connected and disconnected conditions)
- E-Coat 1000 plating

MATERIAL

Female & male couplings in high grade carbon steel.
Male vs. female sealing system in Polyurethane compound; other seals in NBR, back-up ring in PTFE

WORKING TEMPERATURE

-22°F up to +230°F (-30°C up to +110°C)

SAFETY FACTOR

4:1 for dynamic pressures

IMPULSE PRESSURES

1,000,000 cycles at 120% of rated one (freq. 1Hz) in connected and disconnected conditions

TEST SPECIFICATIONS

ISO 18869

NOTE

*This product is intended as a replacement part for the couplings used on the **MQS-MC** type Multiconnector product range.*

*Instructions on removal and fitting of these components can be found in the **Appendices**.*

**Q06811041A
Q06911041A**

BSP TERMINATION ENDS
TO DIN 3852 X TYPE

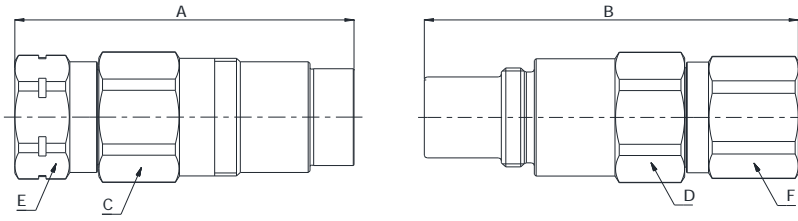

SIZE			PART NUMBER		THREAD	DIMENSIONS mm					
DN	Inch	Dash	Female coupling	Male coupling		A	B	C	D	E	F
10	3/8"	-06	Q06911041A-06-06	Q06811041A-06-06	3/8"	82.3	93.7	30	30	27	27
10	3/8"	-06	Q06911041A-06-08	Q06811041A-06-08	1/2"	85.3	96.5	30	30	27	27
12.5	1/2"	-08	Q06911041A-08-08	Q06811041A-08-08	1/2"	92.5	102	36	36	34	34
12.5	1/2"	-08	Q06911041A-08-12	Q06811041A-08-12	3/4"	94.5	105	36	36	34	34
20	3/4"	-12	Q06911041A-12-12	Q06811041A-12-12	3/4"	108	118.7	41	42	41	41
25	1"	-16	Q06911041A-16-16	Q06811041A-16-16	1"	119.4	126.3	50	50	50	50

SCREW TYPE



Pressure Drop

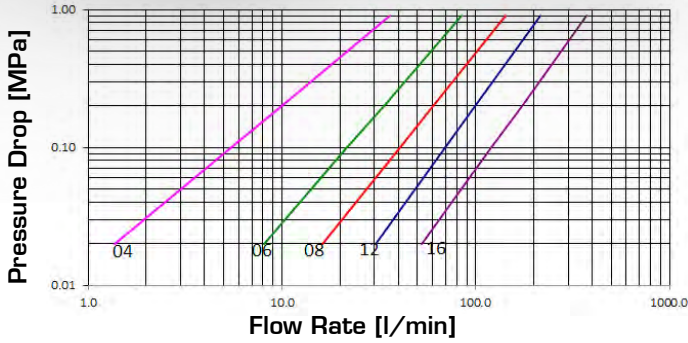

Pressure Drop

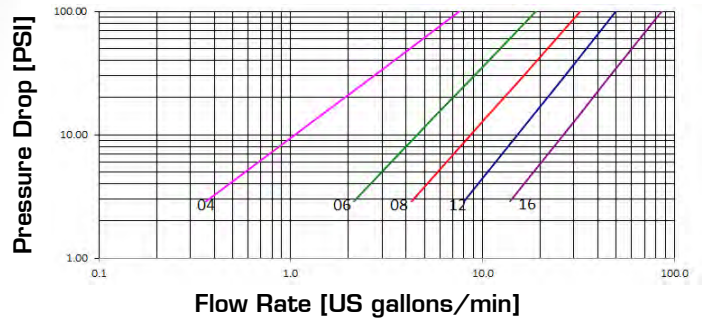

Q.SAFE 430

TECHNICAL DATA

SIZE			MPa		FLOW RATE		OIL SPILLAGE			MINIMUM BURST PRESSURE						CONNECTION / DISCONNECTION UNDER PRESSURE
DN	inch	Dash	MPa	PSI	l/min	US GPM	cc.	cubic inch	Male		Female		M & F			
									MPa	PSI	MPa	PSI	MPa	PSI		
6.3	1/4	04	35	5075	10	2.6	0.8	0.049	145	21025	190	27500	190	27550	Allowed max. 12 MPa	
10	3/8	06	35	5075	34	9.0	1.5	0.092	150	21750	160	23200	150	21750	Allowed max. 10 MPa	
12.5	1/2	08	30	4350	61	16.1	2	0.122	130	18850	140	20300	140	20300	Allowed max. 10 MPa	
20	3/4	12	30	4350	100	26.4	5	0.305	130	18850	130	18850	140	20300	Allowed max. 10 MPa	
25	1	16	25	3625	173	45.7	9	0.549	110	15950	110	15950	110	15950	Allowed max. 10 MPa	

The rated flow represents the normal operating condition. The maximum recommended flow rate is equal to 1.5 times the rated flow

PRODUCT DESCRIPTION

- Screw-type couplings specially designed for heavy duty, high pressure, pressure impulse applications such as hammers, attachments, rock crushers, etc.
- Connection and disconnection is made by screwing the sleeve, also possible with residual pressure in the line
- Connection secured on the thread between the sleeve and the male coupling
- Shut-off by poppet valve
- Hexagon around the male insert to be tightened up or released for maintenance
- Interchangeable with similar products available on the market
- Up to size DN 20 ISO 14541 compliant

MATERIAL

Female coupling in steel, male couplings high standard carbon steel. Carbonitrided valve, springs in C98 steel, seals in NBR (other materials available on request) and back-up ring in PTFE

WORKING TEMPERATURE

-22°F up to +230°F (-30°C up to +110°C)

SAFETY FACTOR

4:1 for dynamic pressures

IMPULSE PRESSURES

200,000 cycles at 133% of the rated one (freq. 1Hz) disconnected; 500,000 connected

TEST SPECIFICATIONS

ISO 18869

ASSEMBLY INSTRUCTIONS

RECOMMENDED TIGHTENING TORQUES

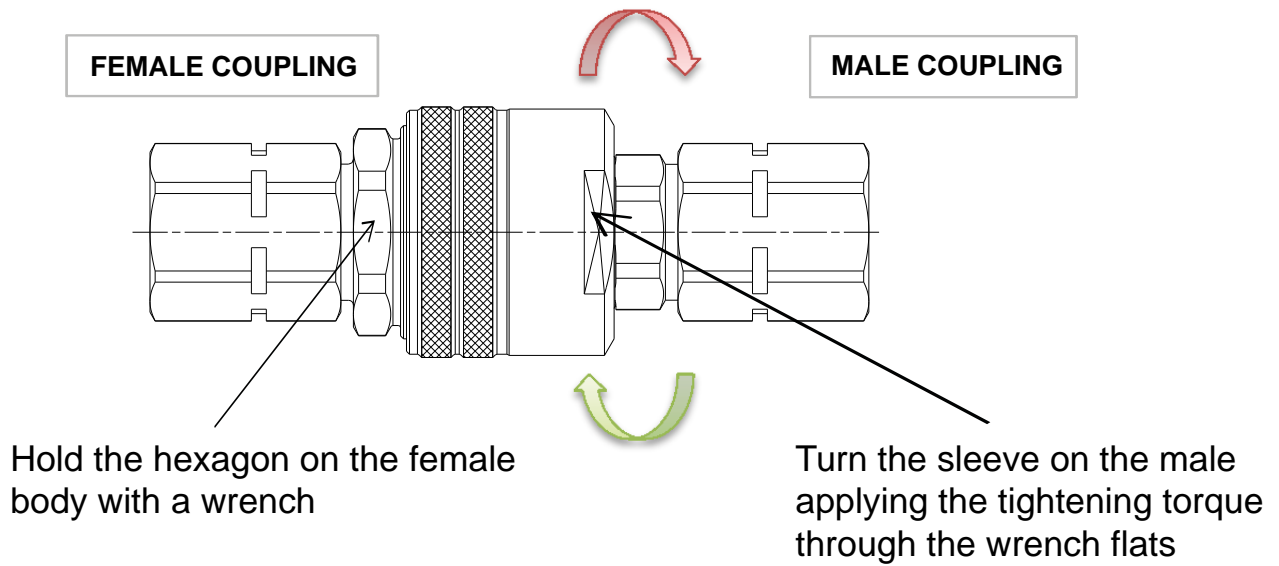

SIZE			TIGHTENING TORQUE
DN	Inch	Dash	Nm
6.3	1/4"	-04	25
10	3/8"	-06	40
12.5	1/2"	-08	70
20	3/4"	-12	100
25	1"	-16	150

Q05211041A Q05111041A

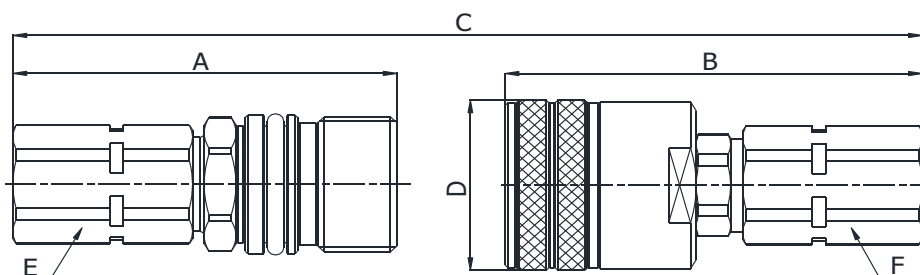

BSP TERMINATION ENDS
TO DIN 3852 X TYPE

SIZE			PART NUMBER		THREAD	DIMENSIONS mm							
DN	Inch	Dash	Female coupling	Male coupling		A	B	C	D	E	F		
6.3	1/4"	-04	Q05211041A-04-04	Q05111041A-04-04	1/4"	61.5	65.5	A+B-24,5	ø30	19	19		
10	3/8"	-06	Q05211041A-06-04	Q05111041A-06-04	1/4"	68	74	A+B-26,5	ø34	22	22		
10	3/8"	-06	Q05211041A-06-06	Q05111041A-06-06	3/8"	69.5	75.5	A+B-26,5	ø34	22	22		
12.5	1/2"	-08	Q05211041A-08-06	Q05111041A-08-06	3/8"	66.5	74.5	A+B-26,5	ø42	27	27		
12.5	1/2"	-08	Q05211041A-08-08	Q05111041A-08-08	1/2"	69.5	77.5	A+B-26,5	ø42	27	27		
20	3/4"	-12	Q05211041A-12-08	Q05111041A-12-08	1/2"	80.8	89.3	A+B-31	ø49	34	34		
20	3/4"	-12	Q05211041A-12-12	Q05111041A-12-12	3/4"	82.8	91.3	A+B-31	ø49	34	34		
25	1"	-16	Q05211041A-16-08	Q05111041A-16-08	1/2"	92.3	99.3	A+B-34,5	ø56	41	41		
25	1"	-16	Q05211041A-16-12	Q05111041A-16-12	3/4"	92.3	99.3	A+B-34,5	ø56	41	41		
25	1"	-16	Q05211041A-16-16	Q05111041A-16-16	1"	95.3	102.3	A+B-34,5	ø56	41	41		

Q.SAFE 432

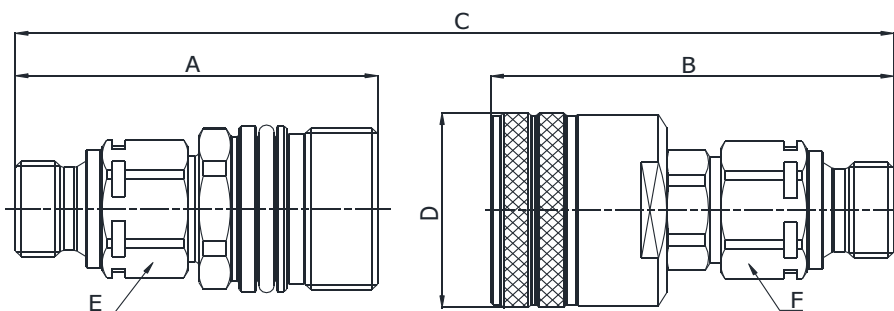

Q05211050A Q05111050A

BSP TERMINATION ENDS
TO ISO 8434-6

SIZE			PART NUMBER		THREAD	DIMENSIONS mm							
DN	Inch	Dash	Female coupling	Male coupling		A	B	C	D	E	F		
12.5	1/2"	-08	Q05211050A-08-06	Q05111050A-08-06	3/8"	69.2	77.2	A+B-26,5	ø42	27	27		
12.5	1/2"	-08	Q05211050A-08-08	Q05111050A-08-08	1/2"	71.7	79.7	A+B-26,5	ø42	27	27		

**Q05211141A
Q05111141A**

METRIC TERMINATION ENDS
TO ISO 3852-1 X TYPE

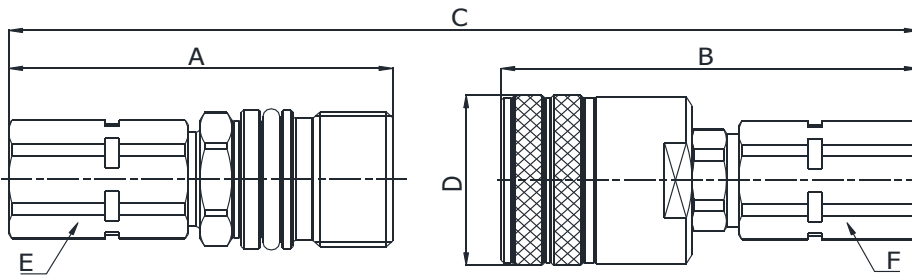

SIZE			PART NUMBER		THREAD	DIMENSIONS mm							
DN	Inch	Dash	Female coupling	Male coupling		A	B	C	D	E	F		
10	3/8"	-06	Q05211141A-06-16	Q05111141A-06-16	M16x1,5	69.5	75.5	A+B-26,5	ø34	22	22		
12.5	1/2"	-08	Q05211141A-08-18	Q05111141A-08-18	M18x1,5	66.5	74.5	A+B-26,5	ø42	27	27		
12.5	1/2"	-08	Q05211141A-08-22	Q05111141A-08-22	M22x1,5	68.5	76.5	A+B-26,5	ø42	27	27		

**Q05211110A
Q05111110A**

METRIC TERMINATION END
TO ISO 8434-1
L SERIES

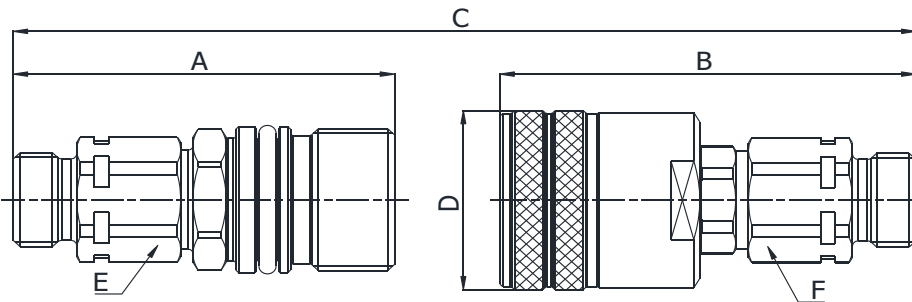

SIZE			PART NUMBER		THREAD	DIMENSIONS mm							
DN	Inch	Dash	Female coupling	Male coupling		A	B	C	D	E	F		
6.3	1/4"	-04	Q05211110A-04-12	Q05111110A-04-12	M12x1,5	59.5	63.5	A+B-24,5	ø30	19	19		
6.3	1/4"	-04	Q05211110A-04-14	Q05111110A-04-14	M14x1,5	59.5	63.5	A+B-24,5	ø30	19	19		
10	3/8"	-06	Q05211110A-06-12	Q05211110A-06-12	M12x1,5	66	72	A+B-26,5	ø34	22	22		
10	3/8"	-06	Q05211110A-06-14	Q05211110A-06-14	M14x1,5	66	72	A+B-26,5	ø34	22	22		
10	3/8"	-06	Q05211110A-06-16	Q05211110A-06-16	M16x1,5	66	72	A+B-26,5	ø34	22	22		
10	3/8"	-06	Q05211110A-06-18	Q05211110A-06-18	M18x1,5	66	72	A+B-26,5	ø34	22	22		
12.5	1/2"	-08	Q05211110A-08-14	Q05111110A-08-14	M14x1,5	65.5	73.5	A+B-26,5	ø42	27	27		
12.5	1/2"	-08	Q05211110A-08-16	Q05111110A-08-16	M16x1,5	66.5	74.5	A+B-26,5	ø42	27	27		
12.5	1/2"	-08	Q05211110A-08-18	Q05111110A-08-18	M18x1,5	65.5	73.5	A+B-26,5	ø42	27	27		
12.5	1/2"	-08	Q05211110A-08-22	Q05111110A-08-22	M22x1,5	66.5	74.5	A+B-26,5	ø42	27	27		
12.5	1/2"	-08	Q05211110A-08-26	Q05111110A-08-26	M26x1,5	66.5	74.5	A+B-26,5	ø42	27	27		
20	3/4"	-12	Q05211110A-12-18	Q05111110A-12-18	M18x1,5	80,8	89,3	A+B-31	ø49	34	34		
20	3/4"	-12	Q05211110A-12-22	Q05111110A-12-22	M22x1,5	80,8	89,3	A+B-31	ø49	34	34		
20	3/4"	-12	Q05211110A-12-26	Q05111110A-12-26	M26x1,5	80,8	89,3	A+B-31	ø49	34	34		
20	3/4"	-12	Q05211110A-12-30	Q05111110A-12-30	M30x2	82,8	91,3	A+B-31	ø49	34	34		
25	1"	-16	Q05211110A-16-26	Q05111110A-16-26	M26x1,5	90,3	97,3	A+B-34,5	ø56	41	41		
25	1"	-16	Q05211110A-16-30	Q05111110A-16-30	M30x2	92,3	99,3	A+B-34,5	ø56	41	41		
25	1"	-16	Q05211110A-16-36	Q05111110A-16-36	M36x2	92,3	99,3	A+B-34,5	ø56	41	41		

Q.SAFE
433

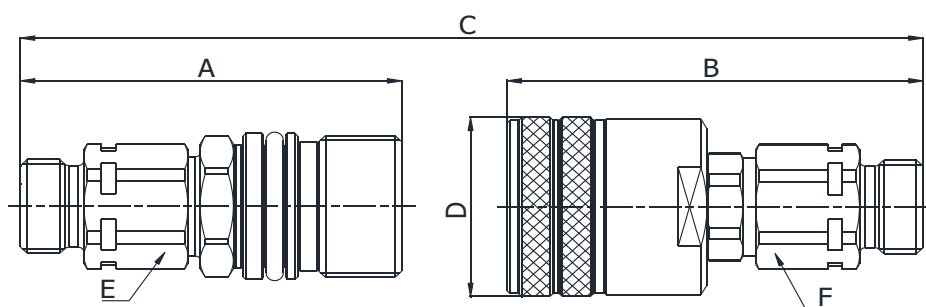

Q05211120A
Q05111120A

METRIC TERMINATION END
TO ISO 8434-1
S SERIES

SIZE			PART NUMBER		THREAD	DIMENSIONS mm							
DN	Inch	Dash	Female coupling	Male coupling		A	B	C	D	E	F		
6.3	1/4"	-04	Q05211120A-04-16	Q05111120A-04-16	M16x1,5	61.5	65.5	A+B-24,5	ø30	19	19		
10	3/8"	-06	Q05211120A-06-16	Q05111120A-06-16	M16x1,5	67	73	A+B-26,5	ø34	22	22		
10	3/8"	-06	Q05211120A-06-18	Q05111120A-06-18	M18x1,5	67	73	A+B-26,5	ø34	22	22		
12.5	1/2"	-08	Q05211120A-08-18	Q05111120A-08-18	M18x1,5	66.5	74.5	A+B-26,5	ø42	27	27		
12.5	1/2"	-08	Q05211120A-08-20	Q05111120A-08-20	M20x1,5	66.5	74.5	A+B-26,5	ø42	27	27		
12.5	1/2"	-08	Q05211120A-08-24	Q05111120A-08-24	M24x1,5	68.5	76.5	A+B-26,5	ø42	27	27		
20	3/4"	-12	Q05211120A-12-20	Q05111120A-12-20	M20x1,5	80.8	89.3	A+B-31	ø49	34	34		
20	3/4"	-12	Q05211120A-12-24	Q05111120A-12-24	M24x1,5	82.8	91.3	A+B-31	ø49	34	34		
20	3/4"	-12	Q05211120A-12-30	Q05111120A-12-30	M30x2	84.8	93.3	A+B-31	ø49	34	34		
25	1"	-16	Q05211120A-16-30	Q05111120A-16-30	M30x2	94,3	101.3	A+B-34,5	ø56	41	41		
25	1"	-16	Q05211120A-16-36	Q05111120A-16-36	M36x2	96,3	103.3	A+B-34,5	ø56	41	41		
25	1"	-16	Q05211120A-16-42	Q05111120A-16-42	M42x2	98,3	105.3	A+B-34,5	ø56	41	41		

Q.SAFE 434

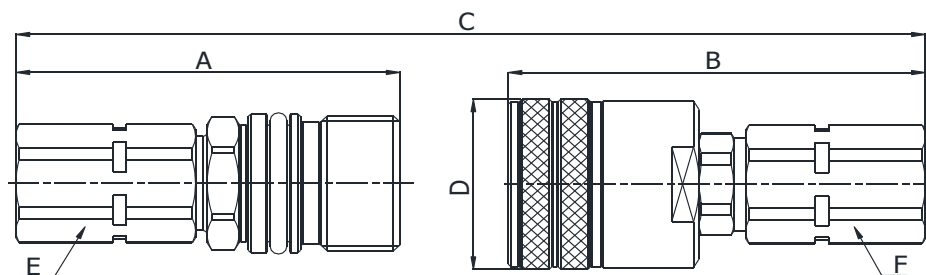

Q05211191A
Q05111191A

METRIC TERMINATION ENDS
TO ISO 6149-1

SIZE			PART NUMBER		THREAD	DIMENSIONS mm							
DN	Inch	Dash	Female coupling	Male coupling		A	B	C	D	E	F		
12.5	1/2"	-08	Q05211191A-08-16	Q05111191A-08-16	M16x1,5	67	75	A+B-26,5	ø42	27	27		
12.5	1/2"	-08	Q05211191A-08-18	Q05111191A-08-18	M18x1,5	68.5	76.5	A+B-26,5	ø42	27	27		

Q05211770B
Q05111770B

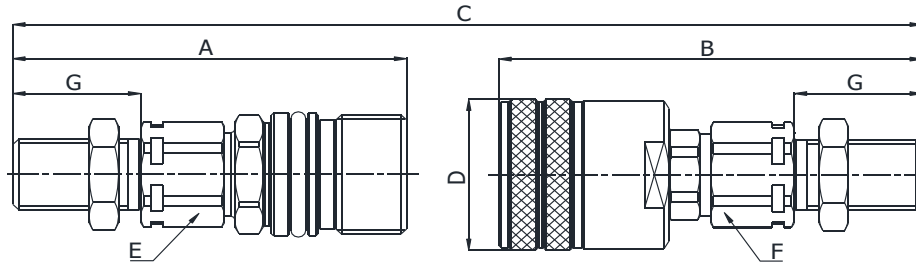

METRIC TERMINATION END
TO ISO 8434-1
BULKHEAD L SERIES

SIZE			PART NUMBER		THREAD	DIMENSIONS mm						
DN	Inch	Dash	Female coupling	Male coupling		A	B	C	D	E	F	G
6.3	1/4"	-04	Q05211770B-04-12	Q05111770B-04-12	M12x1,5	74.5	78.5	A+B-24,5	ø30	19	19	25
6.3	1/4"	-04	Q05211770B-04-14	Q05111770B-04-14	M14x1,5	74.5	78.5	A+B-24,5	ø30	19	19	25
10	3/8"	-06	Q05211770B-06-12	Q05111770B-06-12	M12x1,5	81	87	A+B-26,5	ø34	22	22	25
10	3/8"	-06	Q05211770B-06-14	Q05111770B-06-14	M14x1,5	80	86	A+B-26,5	ø34	22	22	25
10	3/8"	-06	Q05211770B-06-16	Q05111770B-06-16	M16x1,5	80	86	A+B-26,5	ø34	22	22	26
10	3/8"	-06	Q05211770B-06-18	Q05111770B-06-18	M18x1,5	80	86	A+B-26,5	ø34	22	22	26
12.5	1/2"	-08	Q05211770B-08-14	Q05111770B-08-14	M14x1,5	80.5	88.5	A+B-26,5	ø42	27	27	25
12.5	1/2"	-08	Q05211770B-08-16	Q05111770B-08-16	M16x1,5	80.5	88.5	A+B-26,5	ø42	27	27	26
12.5	1/2"	-08	Q05211770B-08-18	Q05111770B-08-18	M18x1,5	80.5	88.5	A+B-26,5	ø42	27	27	26
12.5	1/2"	-08	Q05211770B-08-22	Q05111770B-08-22	M22x1,5	81.5	89.5	A+B-26,5	ø42	27	27	27
12.5	1/2"	-08	Q05211770B-08-26	Q05111770B-08-26	M26x1,5	82.5	90.5	A+B-26,5	ø42	30	30	29
20	3/4"	-12	Q05211770B-12-18	Q05111770B-12-18	M18x1,5	94.8	103.3	A+B-31	ø49	34	34	26
20	3/4"	-12	Q05211770B-12-22	Q05111770B-12-22	M22x1,5	95.8	104.3	A+B-31	ø49	34	34	27
20	3/4"	-12	Q05211770B-12-26	Q05111770B-12-26	M26x1,5	96.8	105.3	A+B-31	ø49	34	34	29
20	3/4"	-12	Q05211770B-12-30	Q05111770B-12-30	M30x2	100.8	109.3	A+B-31	ø49	34	34	32
25	1"	-16	Q05211770B-16-26	Q05111770B-16-26	M26x1,5	106.3	113.3	A+B-34,5	ø56	41	41	29
25	1"	-16	Q05211770B-16-30	Q05111770B-16-30	M30x2	110.3	117.3	A+B-34,5	ø56	41	41	32
25	1"	-16	Q05211770B-16-36	Q05111770B-16-36	M36x2	110.3	117.3	A+B-34,5	ø56	41	41	32

435 Q.SAFE

Q05211870B
Q05111870B

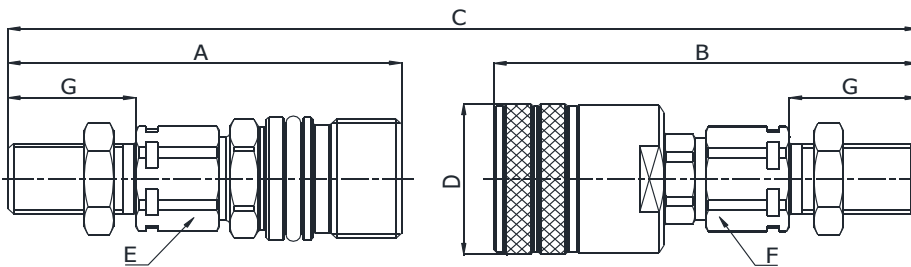

METRIC TERMINATION END
TO ISO 8434-1
BULKHEAD S SERIES

SIZE			PART NUMBER		THREAD	DIMENSIONS mm						
DN	Inch	Dash	Female coupling	Male coupling		A	B	C	D	E	F	G
6.3	1/4"	-04	Q05211870B-04-14	Q05111870B-04-14	M14x1,5	75.5	79.5	A+B-24,5	ø30	19	19	27
6.3	1/4"	-04	Q05211870B-04-16	Q05111870B-04-16	M16x1,5	76.5	77.5	A+B-24,5	ø30	19	19	27
10	3/8"	-06	Q05211870B-06-16	Q05111870B-06-16	M16x1,5	81	87	A+B-26,5	ø34	22	22	27
10	3/8"	-06	Q05211870B-06-18	Q05111870B-06-18	M18x1,5	81	87	A+B-26,5	ø34	22	22	27
12.5	1/2"	-08	Q05211870B-08-18	Q05111870B-08-18	M18x1,5	81.5	89.5	A+B-26,5	ø42	27	27	27
12.5	1/2"	-08	Q05211870B-08-20	Q05111870B-08-20	M20x1,5	81.5	89.5	A+B-26,5	ø42	27	27	27
12.5	1/2"	-08	Q05211870B-08-24	Q05111870B-08-24	M24x1,5	83.5	91.5	A+B-26,5	ø42	27	27	29
20	3/4"	-12	Q05211870B-12-24	Q05111870B-12-24	M24x1,5	97.8	106.3	A+B-31	ø49	34	34	29
20	3/4"	-12	Q05211870B-12-30	Q05111870B-12-30	M30x2	102.8	111.3	A+B-31	ø49	34	34	34
25	1"	-16	Q05211870B-16-30	Q05111870B-16-30	M30x2	112.3	119.3	A+B-34,5	ø56	41	41	34
25	1"	-16	Q05211870B-16-36	Q05111870B-16-36	M36x2	114.3	121.3	A+B-34,5	ø56	41	41	36
25	1"	-16	Q05211870B-16-42	Q05111870B-16-42	M42x2	116.3	123.3	A+B-34,5	ø56	41	41	40

Q05211341A
Q05111341A

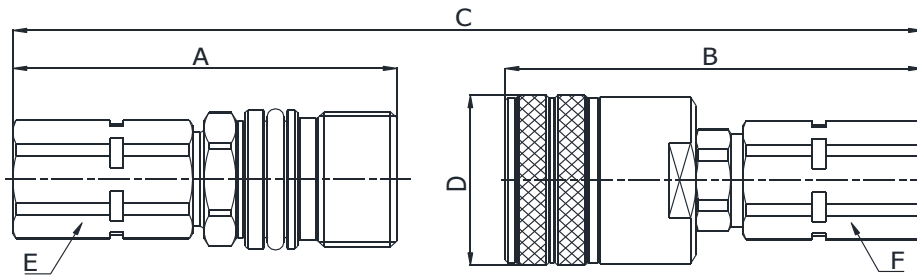

NPTF TERMINATION END
TO ANSI B 1.20.3

SIZE			PART NUMBER		THREAD	DIMENSIONS mm							
DN	Inch	Dash	Female coupling	Male coupling		A	B	C	D	E	F		
6.3	1/4"	-04	Q05211341A-04-04	Q05111341A-04-04	1/4" NPTF	61.5	65.5	A+B-24,5	ø30	19	19		
10	3/8"	-06	Q05211341A-06-06	Q05111341A-06-06	3/8" NPTF	69.5	75.5	A+B-26,5	ø34	22	22		
12.5	1/2"	-08	Q05211341A-08-08	Q05111341A-08-08	1/2" NPTF	69.5	77.5	A+B-26,5	ø42	27	27		
20	3/4"	-12	Q05211341A-12-12	Q05111341A-12-12	3/4" NPTF	82.8	91.3	A+B-31	ø49	34	34		
25	1"	-16	Q05211341A-16-16	Q05111341A-16-16	1" NPTF	95.3	102.3	A+B-34,5	ø56	41	41		

Q.SAFE 436

Q05211301A
Q05111301A

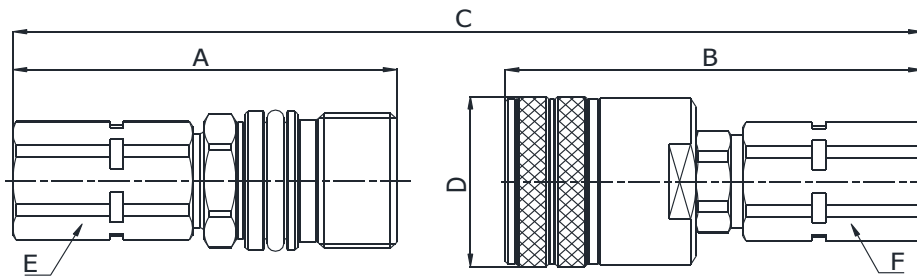

SAE TERMINATION END
TO SAE J1926-1

SIZE			PART NUMBER		THREAD	DIMENSIONS mm							
DN	Inch	Dash	Female coupling	Male coupling		A	B	C	D	E	F		
10	3/8"	-06	Q05211301A-06-06	Q05111301A-06-06	9/16"-18UNF	69.5	75.5	A+B-26,5	ø34	22	22		
12.5	1/2"	-08	Q05211301A-08-08	Q05111301A-08-08	3/4"-16 UNF	69	77	A+B-26,5	ø42	27	27		
12.5	1/2"	-08	Q05211301A-08-10	Q05111301A-08-10	7/8"-14 UNF	71.5	79.5	A+B-26,5	ø42	27	27		

Q05211240A
Q05111240A

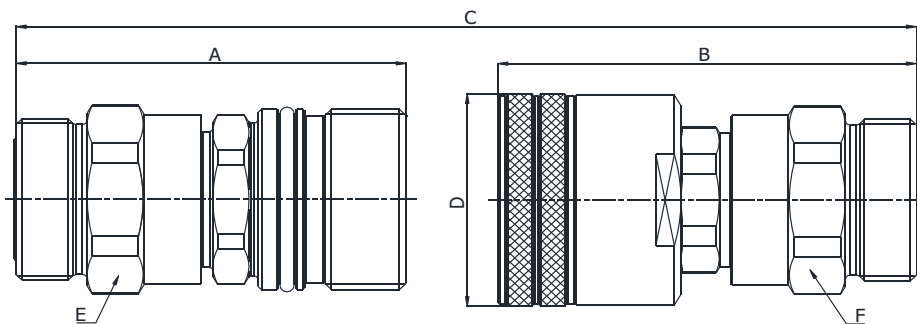

ORFS TERMINATION ENDS
TO ISO 8434-3

SIZE			PART NUMBER		THREAD	DIMENSIONS mm							
DN	Inch	Dash	Female coupling	Male coupling		A	B	C	D	E	F		
25	1"	-16	Q05211240A-16-16	Q05111240A-16-16	1.7/16"-12 UN	98.3	102.8	A+B-34,5	ø56	46	46		
25	1"	-16	Q05211240A-16-20	Q05111240A-16-20	1.11/16"-12UN	95.8	102.8	A+B-34,5	ø56	46	46		



SCREW TYPE HEAVY DUTY

Pressure Drop

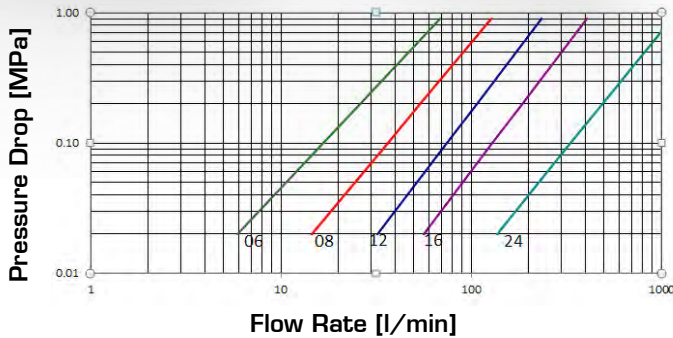

Pressure Drop

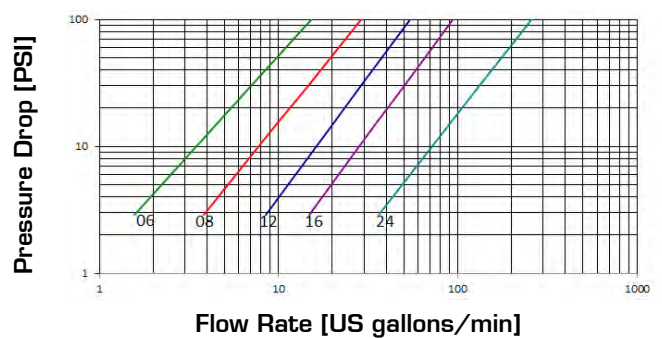

TECHNICAL DATA

SIZE			MPa		FLOW RATE		OIL SPILLAGE		MINIMUM BURST PRESSURE						CONNECTION / DISCONNECTION UNDER PRESSURE
DN	inch	Dash	MPa	PSI	l/min	US GPM	cc.	cubic inch	Male		Female		M & F		Allowed
									MPa	PSI	MPa	PSI	MPa	PSI	
10	3/8	06	35	5075	26	6.9	1.5	0.092	150	21750	160	23200	180	26100	Allowed
12.5	1/2	08	30	4350	54	14.3	2	0.122	130	18850	140	20300	140	20300	Allowed
20	3/4	12	30	4350	107	28.3	5	0.305	130	17750	130	18850	140	20300	Allowed
25	1	16	25	3625	186	49.1	9	0.549	110	15950	110	15950	110	15950	Allowed
38	1 1/2	24	30	4350	492	130.0	25	1.526	130	18850	125	18125	130	18850	Allowed

The rated flow represents the normal operating condition. The maximum recommended flow rate is equal to 1.5 times the rated flow

PRODUCT DESCRIPTION

- Screw-type couplings specially designed for heavy duty applications such as hammers, attachments, rock crushers, etc.
- Thanks to strengthened internal components this series is highly resistant against backflow, flow impulses and peaks, pressure impulses, vibration and hose bending
- Connection and disconnection is made by screwing the sleeve, also possible with rated pressure in the line
- Connection secured on the thread between the sleeve and the male coupling
- Shut-off by poppet valve
- Hexagonal profile of external sleeve for an easy connection and disconnection in high pressure conditions
- Interchangeable with MQS-SG series and similar products available on the market
- Up to size DN 20 ISO 14541 compliant

MATERIAL

Female and male coupling in high standard steel. Carbonitrided valve, springs in C98 steel, seals in NBR (other materials available on request) and back-up ring in PTFE

WORKING TEMPERATURE

-22°F up to +230°F (-30°C up to +110°C)
Specific seals available in case of higher temperatures

SAFETY FACTOR

4:1 for dynamic pressures

IMPULSE PRESSURES

200,000 cycles at 133% of the rated one (freq. 1Hz) disconnected; 500,000 connected

TEST SPECIFICATIONS

ISO 18869

ASSEMBLY INSTRUCTIONS

RECOMMENDED TIGHTENING TORQUES

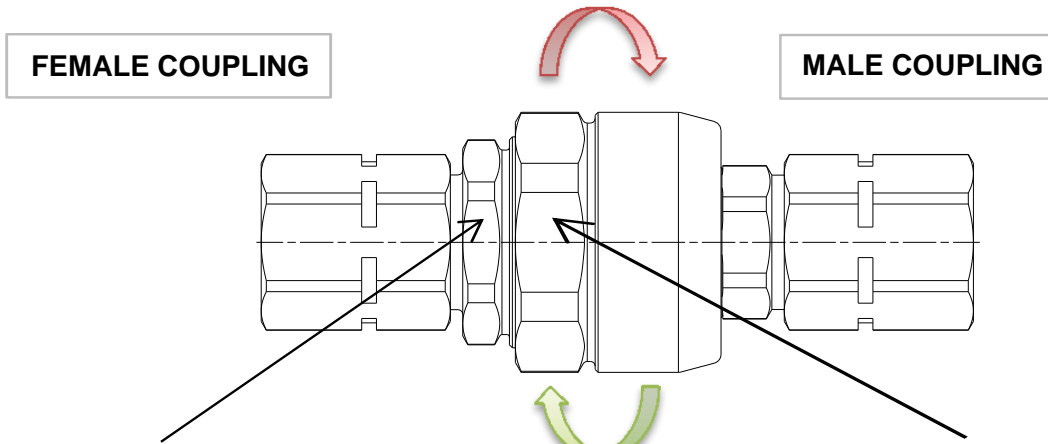

Hold the hexagon on the female body with a wrench

Turn the sleeve on the male applying the tightening torque through the hexagon

SIZE			TIGHTENING TORQUE
DN	Inch	Dash	Nm
10	3/8"	-06	50
12.5	1/2"	-08	80
20	3/4"	-12	120
25	1"	-16	180
38	1-1/2"	-24	300

Q06211041A Q06111041A

BSP TERMINATION ENDS
TO DIN 3852 X TYPE

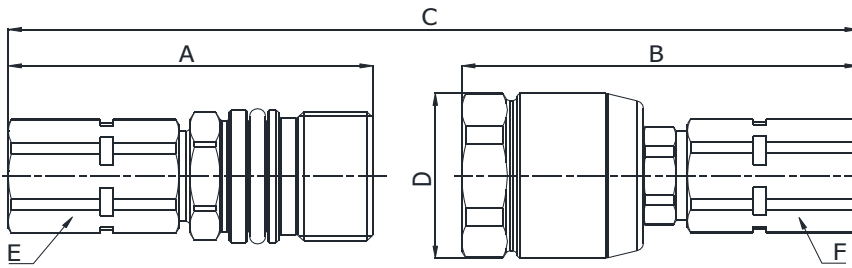

SIZE			PART NUMBER		THREAD	DIMENSIONS mm					
DN	Inch	Dash	Female coupling	Male coupling		A	B	C	D	E	F
10	3/8"	-06	Q06211041A-06-04	Q06111041A-06-04	1/4"	68	74	A+B-26,5	ø34,7	22	22
10	3/8"	-06	Q06211041A-06-06	Q06111041A-06-06	3/8"	69.5	75.5	A+B-26,5	ø34,7	22	22
12.5	1/2"	-08	Q06211041A-08-06	Q06111041A-08-06	3/8"	66.5	74.5	A+B-26,5	ø44,4	27	27
12.5	1/2"	-08	Q06211041A-08-08	Q06111041A-08-08	1/2"	69.5	77.5	A+B-26,5	ø44,4	27	27
20	3/4"	-12	Q06211041A-12-08	Q06111041A-12-08	1/2"	80.8	89.3	A+B-31	ø54,2	34	34
20	3/4"	-12	Q06211041A-12-12	Q06111041A-12-12	3/4"	82.8	91.3	A+B-31	ø54,2	34	34
25	1"	-16	Q06211041A-16-12	Q06111041A-16-12	3/4"	92.3	99.3	A+B-34,5	ø59,6	41	41
25	1"	-16	Q06211041A-16-16	Q06111041A-16-16	1"	95.3	102.3	A+B-34,5	ø59,6	41	41
38	1-1/2"	-24	Q06211041A-24-20	Q06111041A-24-20	1.1/4"	124.5	137.3	A+B-47,5	ø86,6	60	60
38	1-1/2"	-24	Q06211041A-24-24	Q06111041A-24-24	1.1/2"	127.5	140.3	A+B-47,5	ø86,6	60	60

439 Q.SAFE

Q06211870B Q06111870B

METRIC TERMINATION ENDS
BULKHEAD S SERIES

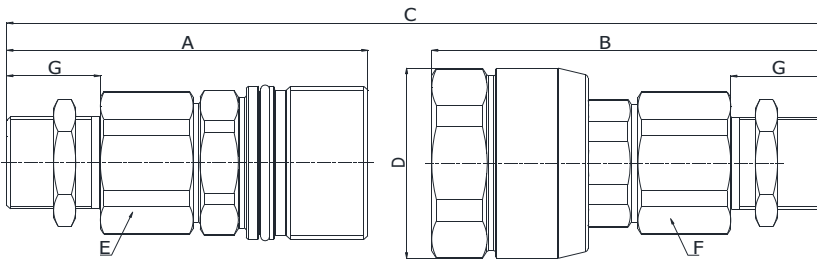

SIZE			PART NUMBER		THREAD	DIMENSIONS mm						
DN	Inch	Dash	Female coupling	Male coupling		A	B	C	D	E	F	
38	1-1/2"	-24	Q06211870B-24-42	Q06111870B-24-42	M42x2	146.7	159.5	A+B-47,3	ø86,6	60	60	38

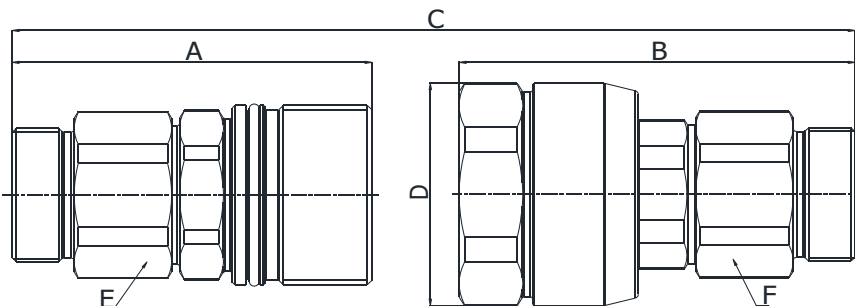

Q06211120A
Q06111120A

METRIC TERMINATION ENDS
TO ISO 8434-1 S SERIES

SIZE			PART NUMBER		THREAD	DIMENSIONS mm					
DN	Inch	Dash	Female coupling	Male coupling		A	B	C	D	E	F
38	1-1/2"	-24	Q06211120A-24-52	Q06111120A-24-52	M52x2	127.6	140	A+B-47,3	ø86,6	60	60

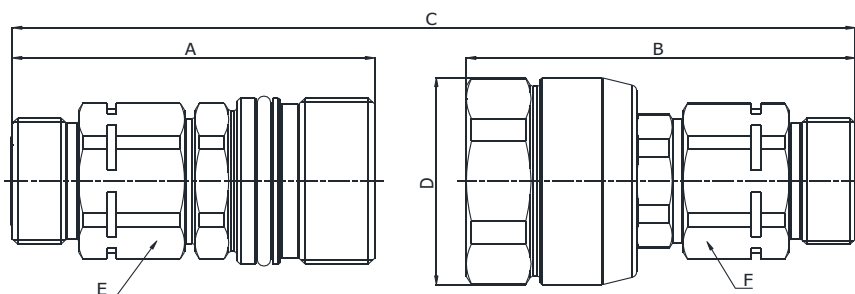

Q06211240A
Q06111240A

ORFS TERMINATION ENDS
TO ISO 8434-3

SIZE			PART NUMBER		THREAD	DIMENSIONS mm					
DN	Inch	Dash	Female coupling	Male coupling		A	B	C	D	E	F
25	1"	-16	Q06211240A-16-16	Q06111240A-16-16	1.7/16"-12 UN	98.3	102.8	A+B-34,5	ø59,6	46	46

Q.SAFE
440

SCREW TYPE HEAVY DUTY

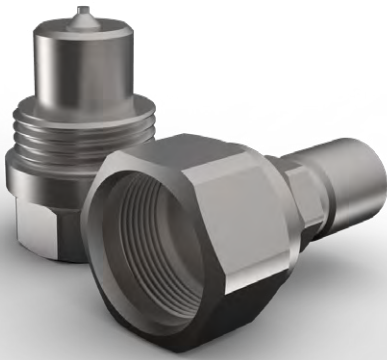

Pressure Drop

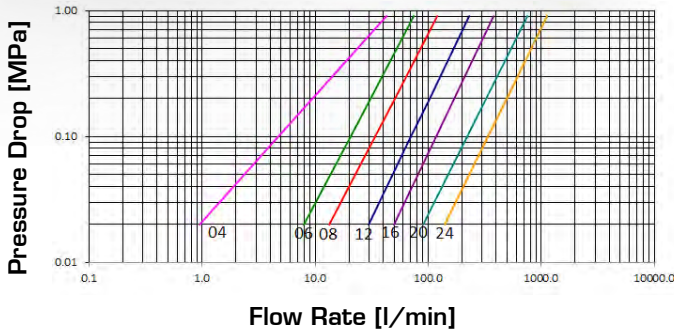

Pressure Drop

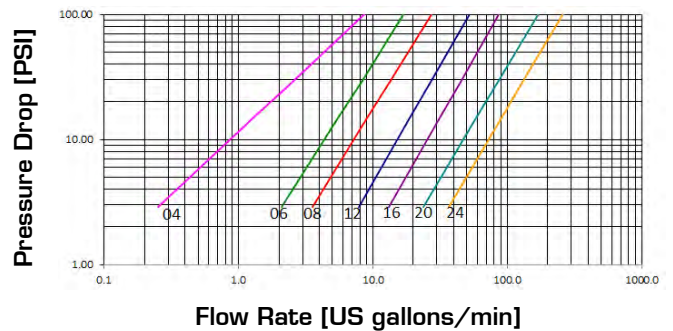

TECHNICAL DATA

SIZE			WORKING PRESSURE (Dynamic)		RATED FLOW at 0.2 MPa of pressure drop		OIL SPILLAGE Connection/ Disconnection		MINIMUM BURST PRESSURE						CONNECTION/ DISCONNECTION UNDER PRESSURE
DN	inch	Dash	MPa	PSI	l/min	US GPM	cc.	cubic inch	Male		Female		M & F		
									MPa	PSI	MPa	PSI	MPa	PSI	
6	¼	04	70	10150	10	2.6	0.4	0.024	290	42050	350	50750	300	43500	Allowed up to 30 MPa
10	⅜	06	60	8700	31	8.2	1.5	0.092	250	36250	330	47850	320	46400	Allowed up to 30 MPa
12.5	½	08	50	7250	51	13.5	2	0.122	200	29000	260	37700	310	44950	Allowed up to 30 MPa
20	¾	12	50	7250	102	26.9	4	0.244	200	29000	250	36250	310	44950	Allowed up to 30 MPa
25	1	16	50	7250	170	44.9	7.5	0.458	200	29000	230	33350	270	39150	Allowed up to 30 MPa
31	1¼	20	40	5800	325	85.9	15	0.916	160	23200	170	24650	230	33350	Allowed up to 15 MPa
38	1½	24	32	4640	494	130.5	23	1.404	130	18850	140	20300	150	21750	Allowed up to 15 MPa

The rated flow represents the normal operating condition. The maximum recommended flow rate is equal to 1.5 times the rated flow

PRODUCT DESCRIPTION

- Screw-on connection/disconnection system
- Sleeve with hexagon area internal components reinforced, made in steel
- Hardened valve bodies
- Three-part poppet valve with a moulded shaped seal
- Mechanical backstop to prevent partial enclosures of valves due to peaks and reverse flow
- Interchangeable with other products and widely used on the market
- Accessories (plugs and caps) and spare part kits available
- Wide range of termination ends

MATERIAL

Couplings in steel with some stressed area hardened.
Carbonitrided valve, springs in C98 steel, seals in NBR and back-up ring in PTFE

WORKING TEMPERATURE

-22°F up to +230°F (-30°C up to +110°C)

SAFETY FACTOR

4:1 for dynamic pressures

IMPULSE PRESSURES

200,000 cycles (connected and disconnected conditions) at 120% of the rated one (freq. 1Hz)

TEST SPECIFICATIONS

ISO 18869

Q.SAFE
44-1

ASSEMBLY INSTRUCTIONS

RECOMMENDED TIGHTENING TORQUES

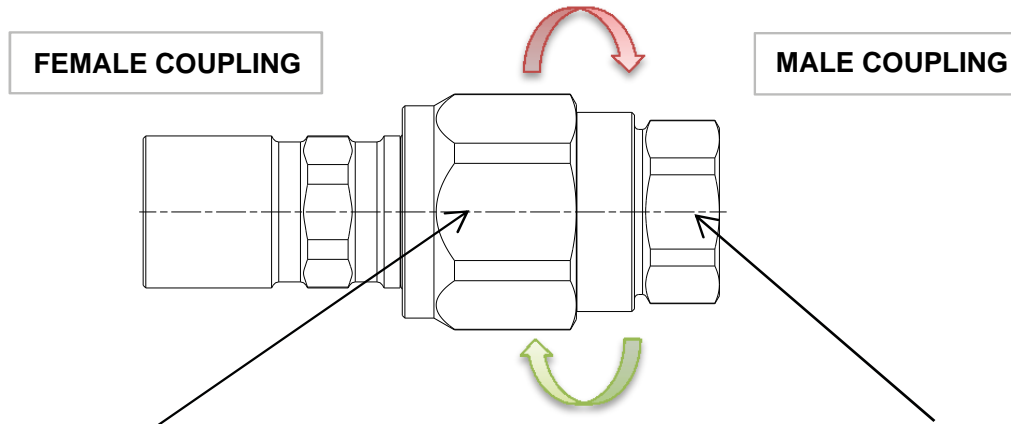

Turn the sleeve on the female applying the tightening torque through the hexagon

Hold the hexagon on the male body with a wrench

SIZE			TIGHTENING TORQUE
DN	Inch	Dash	Nm
6	1/4"	-04	50
10	3/8"	-06	70
12.5	1/2"	-08	100
19	3/4"	-12	150
25	1"	-16	250
31	1-1/4"	-20	400
38	1-1/2"	-24	500

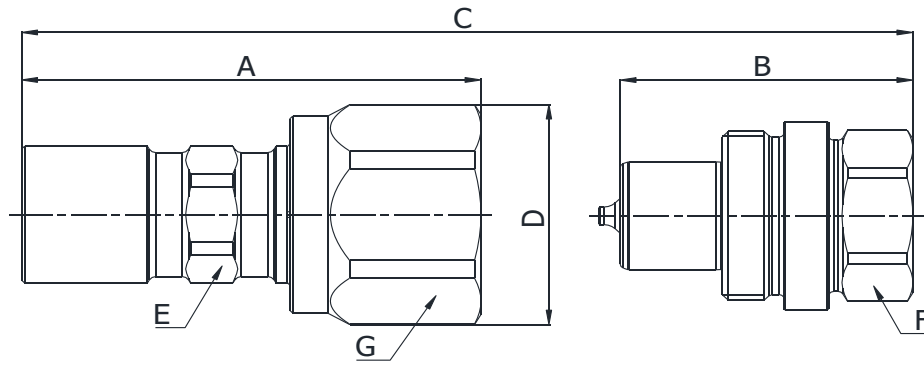

Q05411041A
Q05311041A

BSP TERMINATION ENDS
TO DIN 3852 X TYPE

SIZE			PART NUMBER		THREAD	DIMENSIONS mm						
DN	Inch	Dash	Female coupling	Male coupling		A	B	C	D	E	F	G
6.3	1/4"	-04	Q05411041A-04-04	Q05311041A-04-04	1/4"	63	42.2	A+B-20,8	ø35	19	22	32
10	3/8"	-06	Q05411041A-06-06	Q05311041A-06-06	3/8"	72.5	46.2	A+B-25,9	ø38,5	22	27	35
12.5	1/2"	-08	Q05411041A-08-08	Q05311041A-08-08	1/2"	82.1	54.4	A+B-27,3	ø45	27	32	41
20	3/4"	-12	Q05411041A-12-12	Q05311041A-12-12	3/4"	93.7	61.4	A+B-31,9	ø55	35	41	50
25	1"	-16	Q05411041A-16-16	Q05311041A-16-16	1"	105.8	68.3	A+B-37	ø66	41	50	60
31.5	1.1/4"	-20	Q05411041A-20-20	Q05311041A-20-20	1.1/4"	131.9	82	A+B-53,9	ø88	55	70	80
38	1.1/2"	-24	Q05411041A-24-24	Q05311041A-24-24	1.1/2"	158.9	102	A+B-70,4	ø99	60	80	90

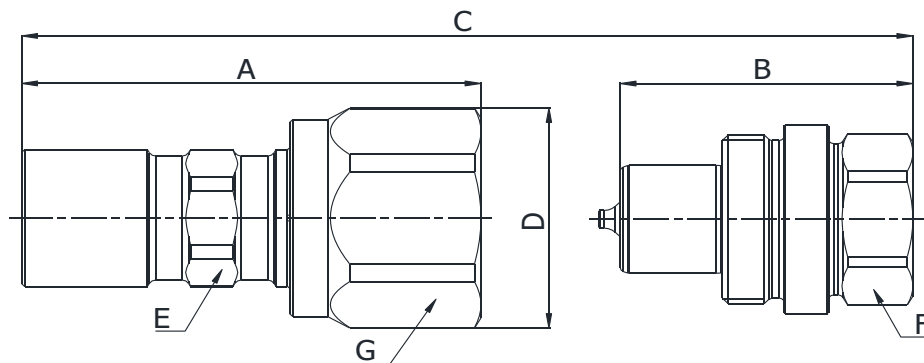

Q05411341A
Q05311341A

NPTF TERMINATION END
TO ANSI B 1.20.3

SIZE			PART NUMBER		THREAD	DIMENSIONS mm						
DN	Inch	Dash	Female coupling	Male coupling		A	B	C	D	E	F	G
6.3	1/4"	-04	Q05411341A-04-04	Q05311341A-04-04	1/4" NPTF	63	42.2	A+B-20,8	ø35	19	22	32
10	3/8"	-06	Q05411341A-06-06	Q05311341A-06-06	3/8" NPTF	72.5	46.2	A+B-25,9	ø38,5	22	27	35
12.5	1/2"	-08	Q05411341A-08-08	Q05311341A-08-08	1/2" NPTF	82.1	54.4	A+B-27,3	ø45	27	32	41
20	3/4"	-12	Q05411341A-12-12	Q05311341A-12-12	3/4" NPTF	93.7	61.4	A+B-31,9	ø55	35	41	50
25	1"	-16	Q05411341A-16-16	Q05311341A-16-16	1" NPTF	105.8	68.3	A+B-37	ø66	41	50	60
31.5	1.1/4"	-20	Q05411341A-20-20	Q05311341A-20-20	1.1/4" NPTF	131.9	82	A+B-53,9	ø88	55	70	80
38	1.1/2"	-24	Q05411341A-24-24	Q05311341A-24-24	1.1/2" NPTF	158.9	102	A+B-70,4	ø99	60	80	90

443 Q.SAFE

SCREW TYPE HYDRAULIC CYLINDERS (POPPET)



Pressure Drop

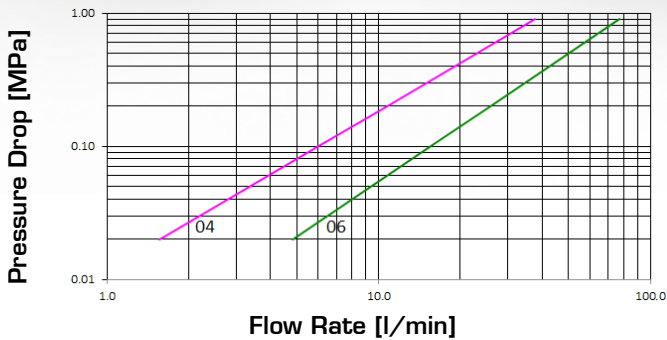

Pressure Drop

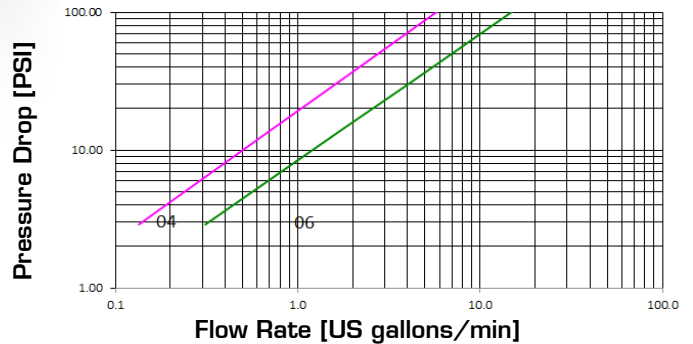

TECHNICAL DATA

SIZE			MPa		FLOW RATE		OIL SPILLAGE		MINIMUM BURST PRESSURE						CONNECTION / DISCONNECTION UNDER PRESSURE
DN	inch	Dash	MPa	PSI	l/min	US GPM	cc.	cubic inch	Male		Female		M & F		Allowed Max. 10 MPa*
									MPa	PSI	MPa	PSI	MPa	PSI	
6.3	1/4	04	72	10440	11	2.9	0.4	0.024	350	50750	310	44950	320	46400	Allowed Max. 10 MPa*
10	3/8	06	72	10440	26	7	0.6	0.037	290	42050	300	43500	290	42050	Allowed Max. 10 MPa*

The rated flow represents the normal operating condition. The maximum recommended flow rate is equal to 1.5 times the rated flow
 *In one part

PRODUCT DESCRIPTION

- Screw-type couplings specially designed for very high pressure applications on cylinders and hydraulic rams
- Connection and disconnection is made by screwing the sleeve and can be made with residual pressure in the line
- Connection secured on the thread between the sleeve and the male coupling
- Shut-off by poppet valve provides effective hydraulic sealing
- Interchangeable with other products and widely used in the USA and Europe
- ISO 14540 compliant

MATERIAL

Female and male coupling in steel. Carbonitrided valve, springs in C98 steel, seals in NBR (other materials available on request) and back-up ring in PTFE

WORKING TEMPERATURE

-22°F up to +230°F (-30°C up to +110°C)
 Specific seals available in case of higher temperatures

SAFETY FACTOR

4:1 for dynamic pressures

IMPULSE PRESSURES

10,000 cycles at 100% of the rated one (freq. 1Hz)

TEST SPECIFICATIONS

ISO 18869

ASSEMBLY INSTRUCTIONS

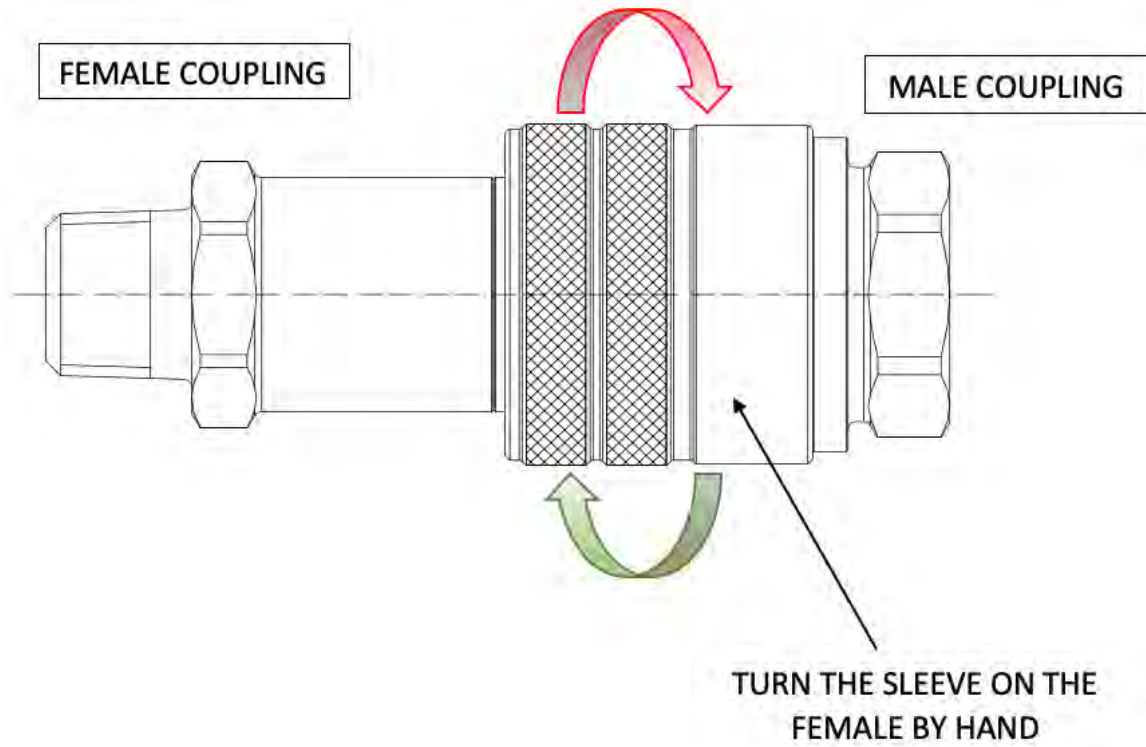

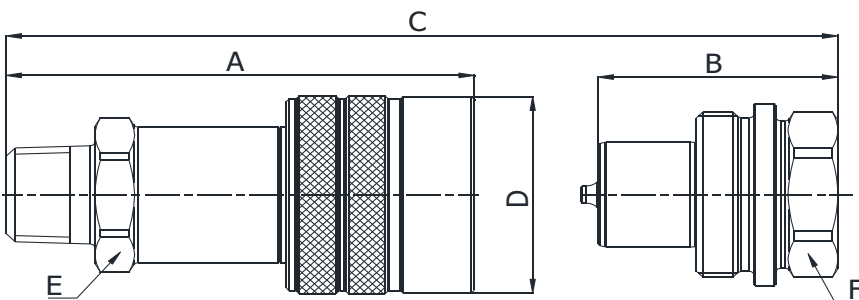

Q05611280B

NPT TERMINATION ENDS
TO ANSI B1.20.3

SIZE			PART NUMBER		THREAD	DIMENSIONS mm					
DN	Inch	Dash	Female coupling	Male coupling		A	B	C	D	E	F
6.3	1/4"	-04	Q05611280B-04-04	-	1/4" NPTF	62.4	-	A+B-19	ø30	21	-
10	3/8"	-06	Q05611280B-06-04	-	1/4" NPTF	76	-	A+B-25	ø35,6	25	-
10	3/8"	-06	Q05611280B-06-06	-	3/8" NPTF	76	-	A+B-25	ø35,6	25	-

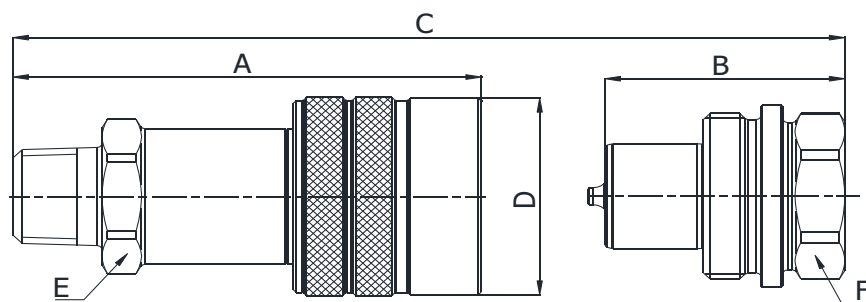

Q05511341B

NPT TERMINATION ENDS
TO ANSI B1.20.3

SIZE			PART NUMBER		THREAD	DIMENSIONS mm					
DN	Inch	Dash	Female coupling	Male coupling		A	B	C	D	E	F
6.3	1/4"	-04	-	Q05511341B-04-04	1/4" NPTF	-	34	A+B-19	-	-	22
10	3/8"	-06	-	Q05511341B-06-04	1/4" NPTF	-	39	A+B-25	-	-	27
10	3/8"	-06	-	Q05511341B-06-06	3/8" NPTF	-	39	A+B-25	-	-	27

SCREW TYPE HYDRAULIC CYLINDERS (BALL)

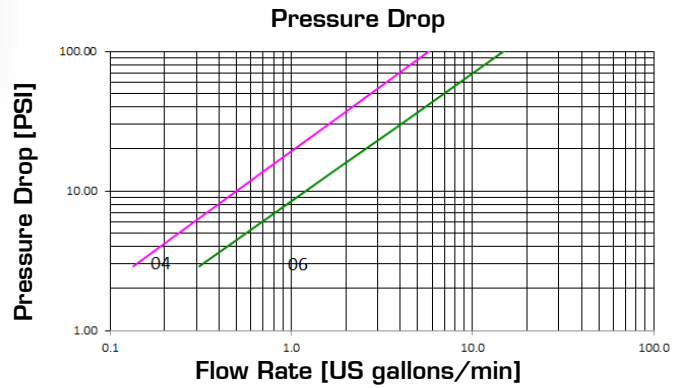
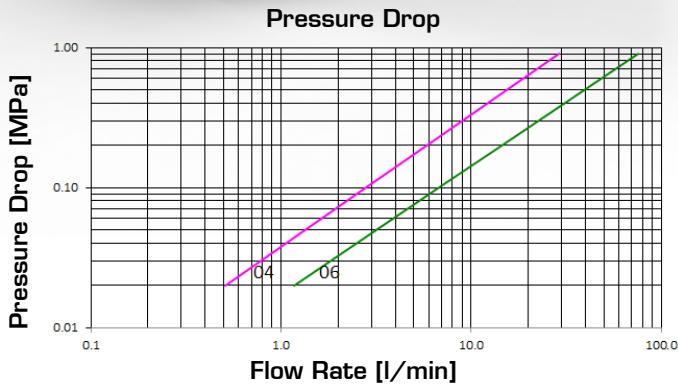

TECHNICAL DATA

SIZE			MPa		FLOW RATE		OIL SPILLAGE Connection/ Disconnection		MINIMUM BURST PRESSURE						CONNECTION/ DISCONNECTION UNDER PRESSURE	
DN	inch	Dash	MPa	PSI	l/min	US GPM	cc.	cubic inch	Male		Female		M & F			
									MPa	PSI	MPa	PSI	MPa	PSI		
6.3	1/4	04	72	10440	11	2.9	0.4	0.024	350	50750	310	44950	320	46400	Allowed Max. 10 MPa*	
10	3/8	06	72	10440	26	7	0.6	0.037	290	42050	300	43500	290	42050	Allowed Max. 10 MPa*	

The rated flow represents the normal operating condition. The maximum recommended flow rate is equal to 1.5 times the rated flow
*In one part

PRODUCT DESCRIPTION

- Screw-type couplings specially designed for very high pressure applications on cylinders and hydraulic rams
- Connection and disconnection is made by screwing the sleeve and can be made with residual pressure in the line
- Connection secured on the thread between the sleeve and the male coupling
- Shut-off by ball valve provides effective hydraulic sealing
- Interchangeable with other products and widely used in the USA and Europe
- ISO 14540 compliant

MATERIAL

Female and male coupling in steel. Carbonitrided valve, springs in C98 steel, seals in NBR (other materials available on request) and back-up ring in PTFE

WORKING TEMPERATURE

-22°F up to +230°F (-30°C up to +110°C)
Specific seals available in case of higher temperatures

SAFETY FACTOR

4:1 for dynamic pressures

IMPULSE PRESSURES

10,000 cycles at 100% of the rated one (freq. 1Hz)

TEST SPECIFICATIONS

ISO 7241-2

ASSEMBLY INSTRUCTIONS

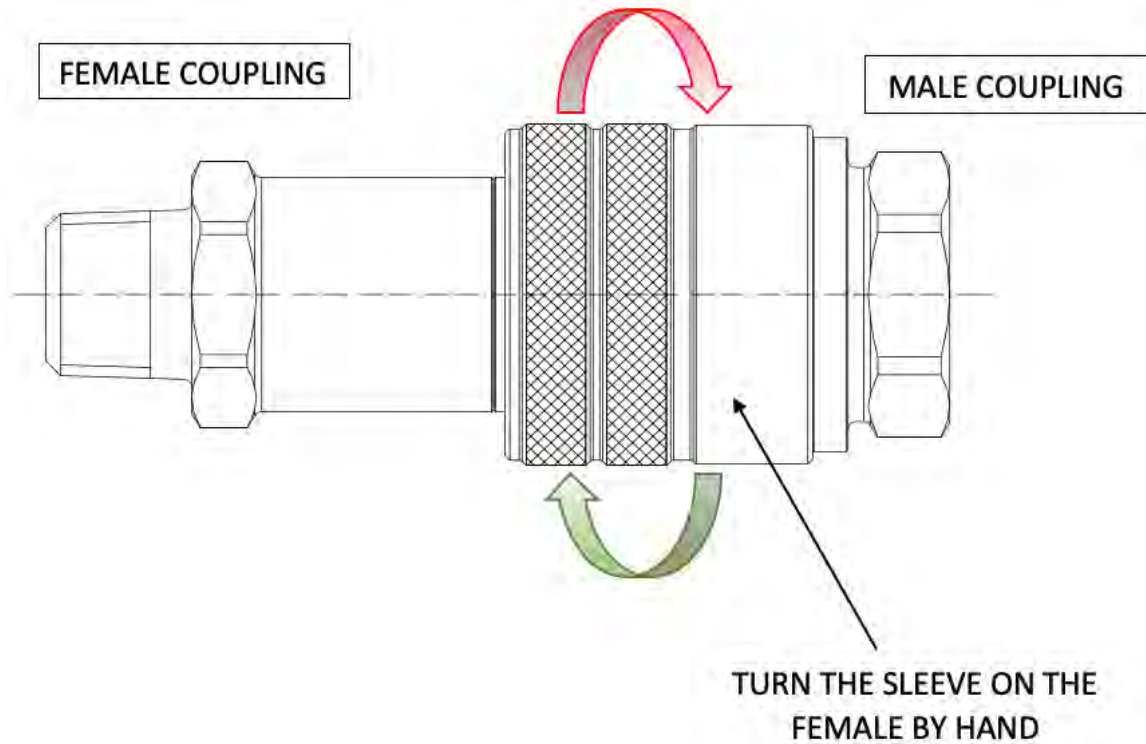

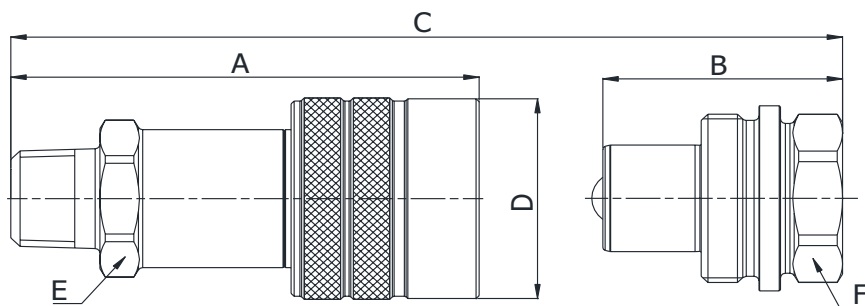

Q05611280C

NPT TERMINATION ENDS
TO ANSI B1.20.3

SIZE			PART NUMBER		THREAD	DIMENSIONS mm					
DN	Inch	Dash	Female coupling	Male coupling		A	B	C	D	E	F
6.3	1/4"	-04	Q05611280C-04-04		1/4" NPTF	62.4	-	A+B-19	ø30	21	-
10	3/8"	-06	Q05611280C-06-04	-	1/4" NPTF	75.6	-	A+B-25	ø35,6	25	-
10	3/8"	-06	Q05611280C-06-06	-	3/8" NPTF	75.6	-	A+B-25	ø35,6	25	-

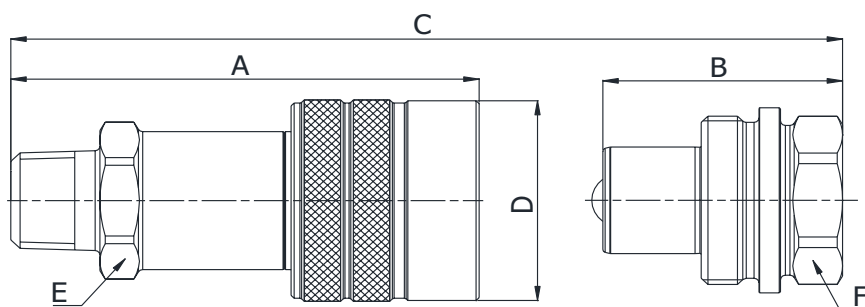

Q05510341C

NPT TERMINATION ENDS
TO ANSI B1.20.3

SIZE			PART NUMBER		THREAD	DIMENSIONS mm					
DN	Inch	Dash	Female coupling	Male coupling		A	B	C	D	E	F
6.3	1/4"	-04	-	Q05510341C-04-04	1/4" NPTF	-	32	A+B-19	-	-	22
10	3/8"	-06	-	Q05510341C-06-04	1/4" NPTF	-	39	A+B-25	-	-	27
10	3/8"	-06	-	Q05510341C-06-06	3/8" NPTF	-	39	A+B-25	-	-	27



SCREW TYPE FOR OIL & GAS

Pressure Drop

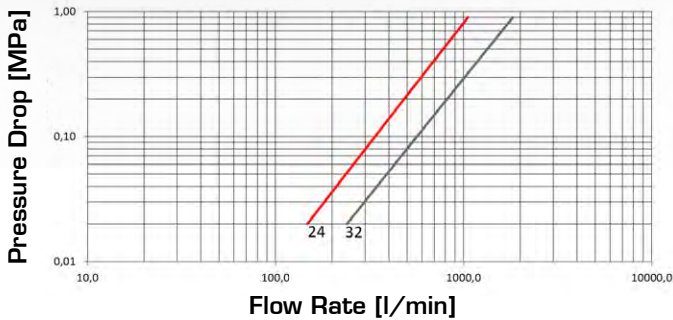

Pressure Drop

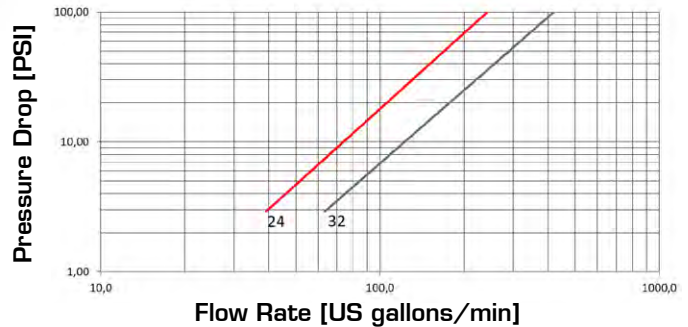

Q.SAFE 450

TECHNICAL DATA

SIZE			WORKING PRESSURE				FLOW RATE		OIL SPILLAGE		MINIMUM BURST PRESSURE						CONNECTION/ DISCONNECTION UNDER PRESSURE
DN	inch	Dash	MPa		PSI		l/min	US GPM	cc.	cubic inch	Male		Female		M & F		Residual pressure
			MPa	PSI	MPa	PSI					MPa	PSI	MPa	PSI	MPa	PSI	
38	1-1/2	-24	35	5075	25	3625	485	128.1	35	2.137	100	14500	120	17400	150	21750	Residual pressure
51	2	-32	35	5075	25	3625	820	216.6	80	4.884	100	14500	100	14500	180	26100	Residual pressure

The rated flow represents the normal operating condition. The maximum recommended flow rate is equal to 1.5 times the rated flow

PRODUCT DESCRIPTION

- Screw-type couplings specially designed for Oil & Gas applications
- Wing Nut shaped sleeve for easier connection and disconnection by hand, also in case of residual pressure in the line
- Connection secured on the thread between the sleeve and the female coupling
- Inspection holes to check full connection
- Shut-off by poppet valve
- Interchangeable with similar products available on the market

MATERIAL

Female and male couplings in high grade carbon steel. Springs in C98 steel, seals in NBR (other materials available on request) and back-up ring in PTFE

WORKING TEMPERATURE

-22°F up to +230°F (-30°C up to +110°C)

SAFETY FACTOR

4:1 for dynamic pressures

IMPULSE PRESSURES

500,000 cycles at 120% of the rated one (freq. 1Hz) in connected and disconnected conditions.

TEST SPECIFICATIONS

ISO 18869

ASSEMBLY INSTRUCTIONS

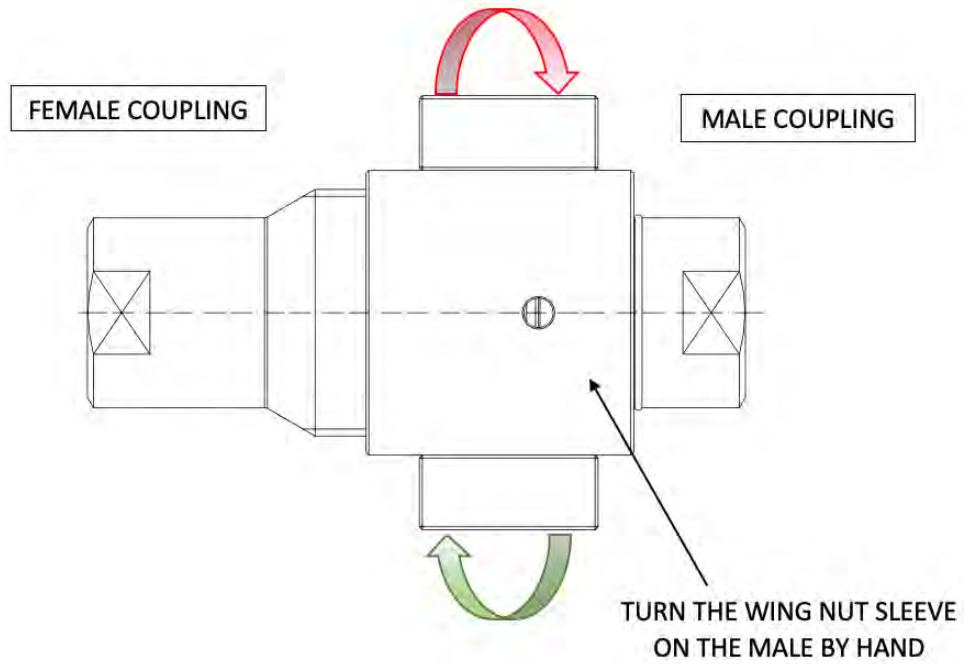

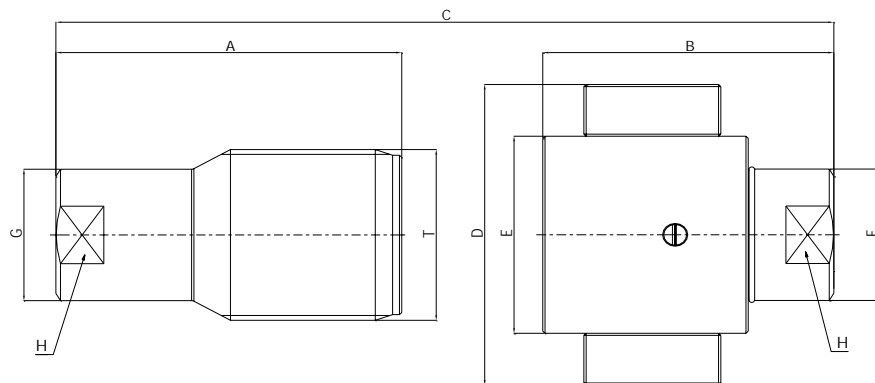

Q07711041A
Q07611041A

BSP TERMINATION ENDS
TO DIN 3852 X TYPE

SIZE			PART NUMBER		THREAD	DIMENSIONS mm								
DN	Inch	Dash	Female coupling	Male coupling		A	B	C	D	E	F	G	H	T
38	1-1/2	-24	Q07711041A-24-24	Q07611041A-24-24	1.1/2"	151.5	127.5	A+B-40,5	145.2	ø95,2	ø63,5	ø63,5	57.1	STUB ACME 3-1/4 - 4
51	2	-32	Q07711041A-32-32	Q07611041A-32-32	2"	179	154	A+B-51	168.7	ø118,7	ø83	ø82,5	76.2	STUB ACME 4 - 4

SCREW TYPE FOR TRUCKS

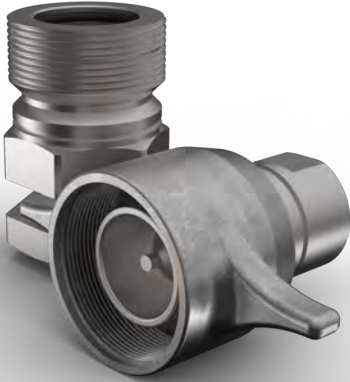

Pressure Drop

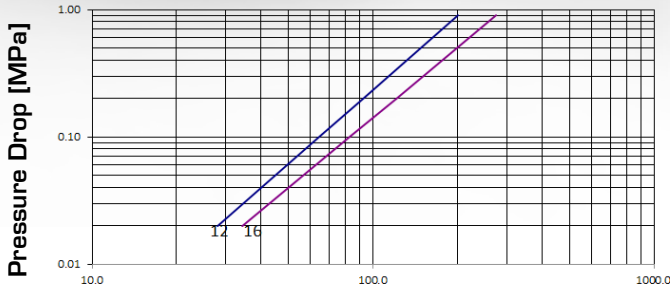

Flow Rate [l/min]

Pressure Drop

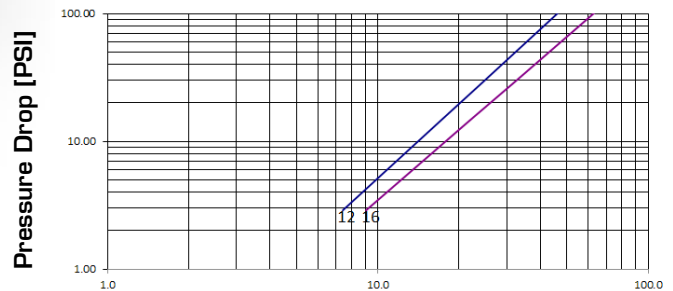

Flow Rate [US gallons/min]

TECHNICAL DATA

SIZE			MPa		FLOW RATE		OIL SPILLAGE Connection/ Disconnection		MINIMUM BURST PRESSURE						CONNECTION/ DISCONNECTION UNDER PRESSURE
DN	inch	Dash	MPa	PSI	l/min	US GPM	cc.	cubic inch	Male		Female		M & F		
									MPa	PSI	MPa	PSI	MPa	PSI	
20	¾	12	25	3625	92	24.3	7.5	0.458	100	14500	120	17400	110	15950	Residual pressure
25	1	16	25	3625	121	32.0	9	0.549	120	17400	140	20300	130	18850	Residual pressure

The rated flow represents the normal operating condition. The maximum recommended flow rate is equal to 1.5 times the rated flow

PRODUCT DESCRIPTION

- Screw-type couplings specially designed for truck trailer applications
- Wing Nut shaped sleeve for easier connection and disconnection by hand, also in case of residual pressure in the line
- Connection secured on the thread between the sleeve and the male coupling
- Shut-off by poppet valve
- Interchangeable with similar products available on the market

MATERIAL

Female and male coupling in steel. Carbonitrided valve, springs in C98 steel, seals in NBR (other materials available on request) and back-up ring in PTFE

WORKING TEMPERATURE

-22°F up to +230°F (-30°C up to +110°C)

SAFETY FACTOR

4:1 for dynamic pressures and 2:1 for static pressures

TEST SPECIFICATIONS

ISO 18869

ASSEMBLY INSTRUCTIONS

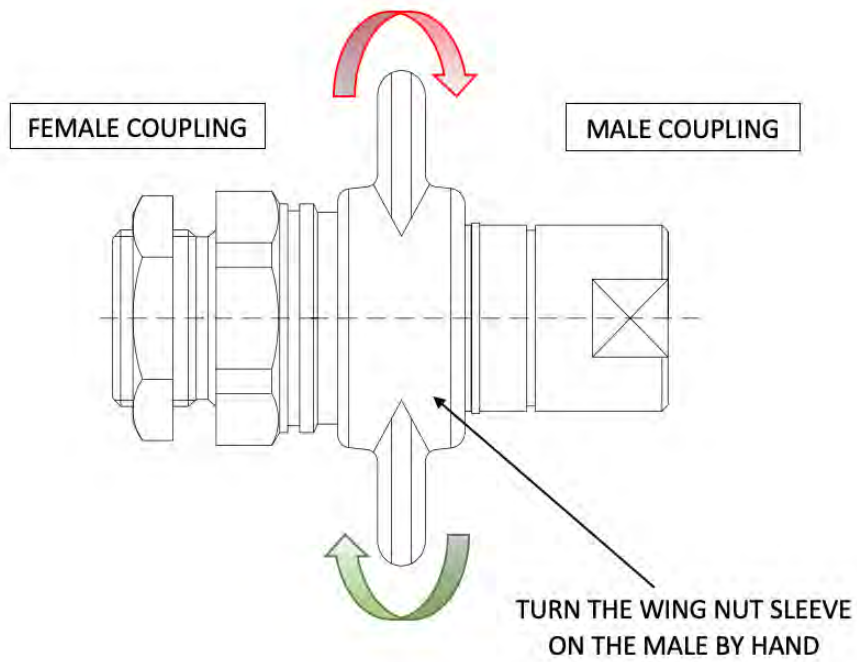

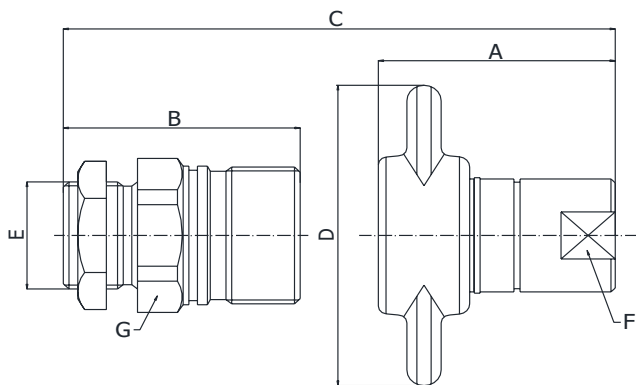

Q05811041A
Q05711041A

BSP TERMINATION ENDS
TO DIN 3852 X TYPE

SIZE			PART NUMBER		THREAD	DIMENSIONS mm							
DN	Inch	Dash	Female coupling	Male coupling		A	B	C	D	E	F	G	
20	3/4"	-12	Q05811041A-12-12	Q05711041A-12-12	3/4"	78	78	138	117	1.1/4"	33	46	
25	1"	-16	Q05811041A-16-16	Q05711041A-16-16	1"	83	83	148	117	1.1/4"	40	55	



STAINLESS STEEL ISO B POPPET VALVE

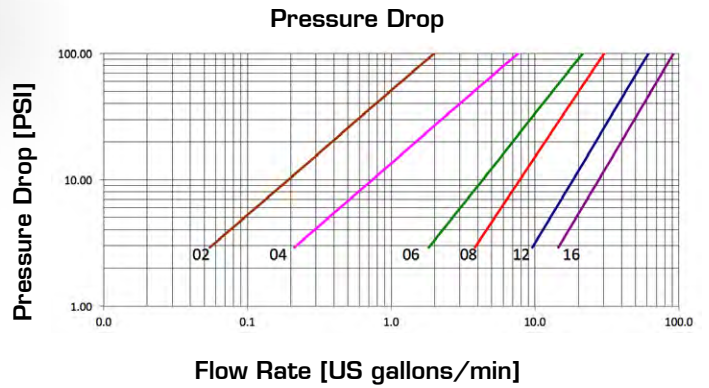
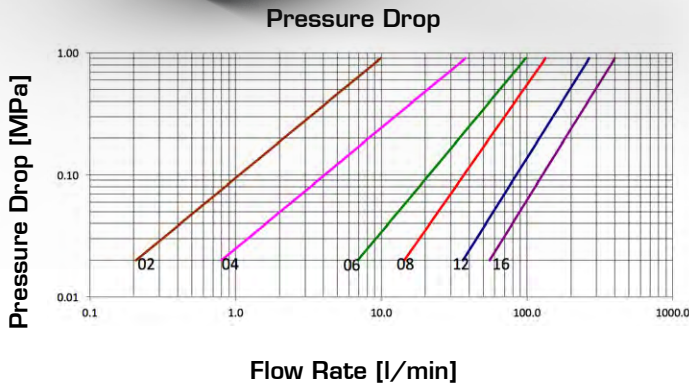

Q.SAFE 456

TECHNICAL DATA

SIZE			MPa		FLOW RATE		N		OIL SPILLAGE Connection/Disconnection		MINIMUM BURST PRESSURE						CONNECTION/DISCONNECTION UNDER PRESSURE	
DN	inch	Dash	MPa	PSI	l/min	US GPM	N	lb.	cc.	cubic inch	Male		Female		M & F			
										MPa	PSI	MPa	PSI	MPa	PSI			
5	1/8	02	40	5800	2	0.6	28	6.3	0.5	0.031	210	30450	280	40600	160	23200	Not allowed	
6.3	1/4	04	35	5075	8	2.2	36	8.1	0.8	0.049	150	21750	220	31900	230	33350	Not allowed	
10	3/8	06	30	4350	34	9.1	38	8.5	1.5	0.092	130	18850	160	23200	180	26100	Not allowed	
12.5	1/2	08	30	4350	55	14.6	50	11.2	2.5	0.153	120	17400	130	18850	140	20300	Not allowed	
20	3/4	12	25	3625	122	32.1	56	12.6	8.5	0.519	110	15950	110	15950	130	18850	Not allowed	
25	1	16	25	3625	183	48.3	56	12.6	15.0	0.915	110	15950	110	15950	100	14500	Not allowed	

The rated flow represents the normal operating condition. The maximum recommended flow rate is equal to 1.5 times the rated flow

PRODUCT DESCRIPTION

- Reference series for all industrial applications
- Simple connection and disconnection by pulling back the sleeve
- Positive, quick connection of the male into the female by latching the ball system
- Shut-off by poppet valve
- High resistant materials
- Interchangeable according to ISO 7241 series B
- FKM (VITON) seal

MATERIAL

Female and male in AISI 316 steel. Couplings in high grade carbon steel hardened. Springs in C98 steel, seals in FKM (VITON) (other materials on request) and back-up ring in PTFE

WORKING TEMPERATURE

-25°C up to +200°C
For other temperatures, the quick coupling is assembled with specific seals

SAFETY FACTOR

4:1 for dynamic pressures

IMPULSE PRESSURES

Withstands 100,000 cycles of impulse pressure at 133% of the rated one (freq. 1Hz)

TEST SPECIFICATIONS

ISO 18869

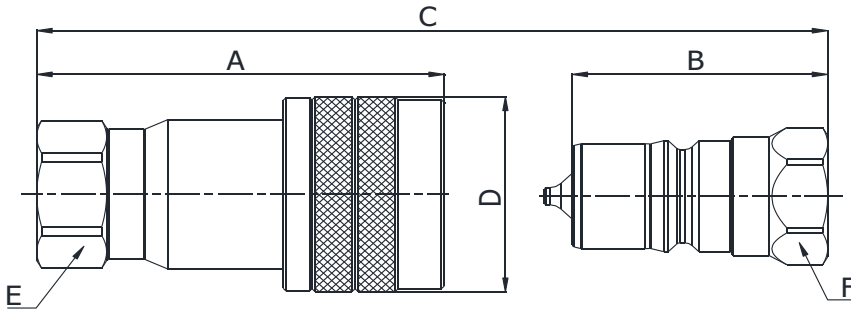

Q02423041A
Q02123041A

BSP TERMINATION ENDS
TO DIN 3852 X TYPE
FKM SEAL

SIZE			PART NUMBER		THREAD	DIMENSIONS mm					
DN	Inch	Dash	Female coupling	Male coupling		A	B	C	D	E	F
5	1/8"	-02	Q02423041A-02-02	Q02123041A-02-02	1/8"	48.5	30	A+B-18,2	ø22	15	14
6.3	1/4"	-04	Q02423041A-04-04	Q02123041A-04-04	1/4"	58.8	37.2	A+B-21,2	ø28	19	19
10	3/8"	-06	Q02423041A-06-06	Q02123041A-06-06	3/8"	66.2	41.5	A+B-24,4	ø35	24	22
12.5	1/2"	-08	Q02423041A-08-08	Q02123041A-08-08	1/2"	74	46.5	A+B-27,2	ø42	30	27
20	3/4"	-12	Q02423041A-12-12	Q02123041A-12-12	3/4"	91	56.5	A+B-34,2	ø52	36	36
25	1"	-16	Q02423041A-16-16	Q02123041A-16-16	1"	104	64.5	A+B-39,2	ø60	41	41

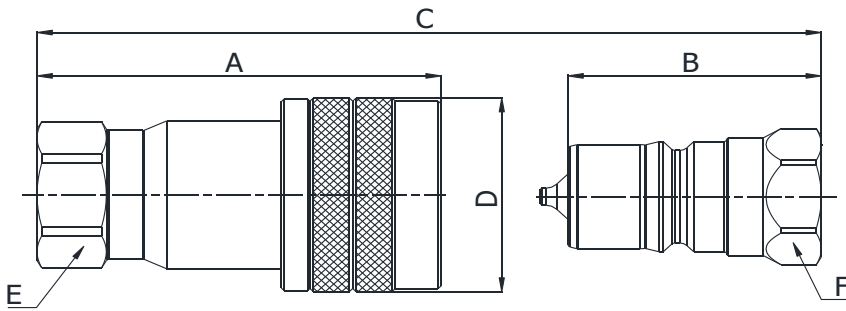

Q02423341A
Q02123341A

NPTF TERMINATION END
TO ANSI B 1.20.3
FKM SEAL

SIZE			PART NUMBER		THREAD	DIMENSIONS mm					
DN	Inch	Dash	Female coupling	Male coupling		A	B	C	D	E	F
5	1/8"	-02	Q02423341A-02-02	Q02123341A-02-02	1/8" NPTF	48.5	30	A+B-18,2	ø22	15	14
6.3	1/4"	-04	Q02423341A-04-04	Q02123341A-04-04	1/4" NPTF	58.8	37.2	A+B-21,2	ø28	19	19
10	3/8"	-06	Q02423341A-06-06	Q02123341A-06-06	3/8" NPTF	66.2	41.5	A+B-24,4	ø35	24	22
12.5	1/2"	-08	Q02423341A-08-08	Q02123341A-08-08	1/2" NPTF	74	46.5	A+B-27,2	ø42	30	27
20	3/4"	-12	Q02423341A-12-12	Q02123341A-12-12	3/4" NPTF	91	56.5	A+B-34,2	ø52	36	36
25	1"	-16	Q02423341A-16-16	Q02123341A-16-16	1" NPTF	104	64.5	A+B-39,2	ø60	41	41



STAINLESS STEEL FLAT FACE

Pressure Drop

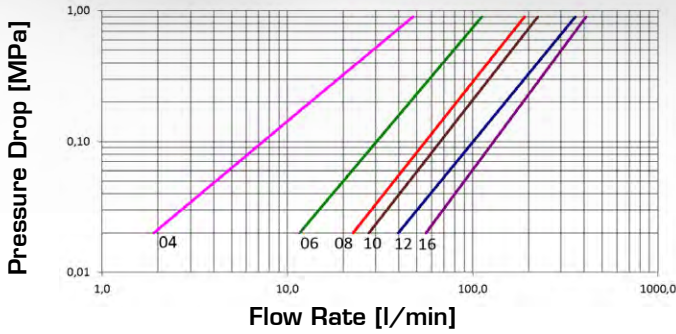

Pressure Drop

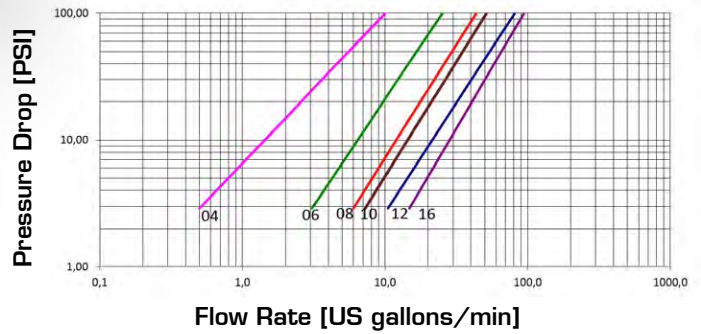

Q.SAFE 458

TECHNICAL DATA

SIZE		WORKING PRESSURE CONNECTED [Dynamic]		WORKING PRESSURE DISCONNECTED [Dynamic]		RATED FLOW at 0.2 MPa of pressure drop		CONNECTION EFFORT		OIL SPILLAGE Connection/ Disconnection	MINIMUM BURST PRESSURE						CONNECTION WITH FEMALE UNDER PRESSURE (MALE AT 0 MPa)		
DN	inch	Dash	MPa	PSI	MPa	PSI	l/min	US GPM	N	lb.	cc.	cubic inch	Male MPa	Male PSI	Female MPa	Female PSI	M & F MPa	M & F PSI	
6.3	1/4"	04	35	5075	32	4640	13	3.4	120	27.0	0.005	0.0003	200	29000	130	18850	220	31900	Allowed up to 6 MPa
10	3/8"	06	35	5075	32	4640	46	12.2	130	29.2	0.007	0.0004	180	26100	130	18850	170	24650	Allowed up to 6 MPa
12.5	1/2"	08	35	5075	25	3625	82	21.7	150	33.7	0.008	0.0005	100	14500	100	14500	140	20300	Allowed up to 4 MPa
16	5/8"	10	35	5075	25	3625	98	25.9	160	36.0	0.008	0.0005	100	14500	100	14500	140	20300	Allowed up to 3 MPa
19	3/4"	12	35	5075	22	3190	150	39.6	210	47.2	0.009	0.0005	90	13050	100	14500	140	20300	Allowed up to 2 MPa
25	1"	16	35	5075	21	3045	186	49.1	210	47.2	0.02	0.0012	110	15950	85	12325	140	20300	Allowed up to 2 MPa

Connection with Male under pressure not allowed; Disconnection under pressure not allowed
 The rated flow represents the normal operating condition. The maximum recommended flow rate is equal to 1.5 times the rated flow

PRODUCT DESCRIPTION

- Flat mating surfaces easily wiped clean to prevent contamination and spillage during connection/disconnection
- Connection is made by pushing the male coupling and disconnection by pulling back the sleeve of the female
- Positive, quick connection of the male into the female by the latching ball system
- Shut-off by flat valve
- Interchangeability according to ISO 16028 and HTMA standards (only for 3/8")
- 1,000,000 cycles at 120% of rated (freq. 1Hz - connected conditions)
- FKM (VITON) seal

MATERIAL

Female and male coupling in steel, with some stressed tempered or carbonitrided areas. Springs in AISI and C98 steel, FKM (VITON) seal. Other materials (VITON, EPDM or any others) on request

WORKING TEMPERATURE

-25°C up to +200°C
 For other temperatures the coupling is assembled with the specified seals

SAFETY FACTOR

4:1 for dynamic pressures

IMPULSE PRESSURES

100,000 cycles at 133% of the rated one (freq. 1Hz) in disconnected conditions. 1,000,000 cycles at 120% of rated one (freq. 1Hz) in connected conditions.

TEST SPECIFICATIONS

ISO 18869

Q04123041A
Q03923041A

BSP TERMINATION ENDS
 TO DIN 3852 X TYPE

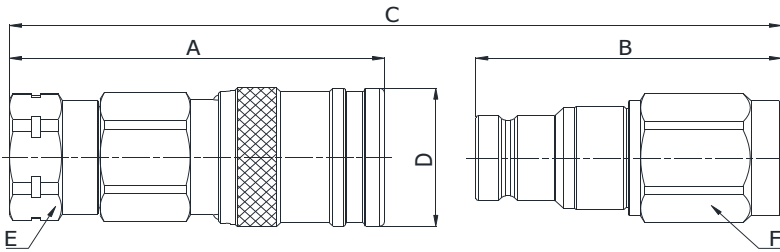

SIZE			PART NUMBER		THREAD	DIMENSIONS mm							
DN	Inch	Dash	Female coupling	Male coupling		A	B	C	D	E	F		
6.3	1/4"	-04	Q04123041A-04-04	Q03923041A-04-04	1/4"	65.2	52.4	A+B-11,1	ø28	24	22		
10	3/8"	-06	Q04123041A-06-06	Q03923041A-06-06	3/8"	78.3	63.8	A+B-15,9	ø32	27	27		
10	3/8"	-06	Q04123041A-06-08	Q03923041A-06-08	1/2"	81.3	67.8	A+B-15,9	ø32	27	27		
12.5	1/2"	-08	Q04123041A-08-08	Q03923041A-08-08	1/2"	88.5	71.3	A+B-17,1	ø38	36	36		
12.5	1/2"	-08	Q04123041A-08-12	Q03923041A-08-12	3/4"	90.5	75.8	A+B-17,1	ø38	36	36		
16	5/8"	-10	Q04123041A-10-12	Q03923041A-10-12	3/4"	94.6	76.4	A+B-17,6	ø42	36	36		
19	3/4"	-12	Q04123041A-12-12	Q03923041A-12-12	3/4"	108	89.8	A+B-21.7	ø48	41	41		
25	1"	-16	Q04123041A-16-16	Q03923041A-16-16	1"	119.4	92.1	A+B-22,9	ø55	50	50		

Q04123341A
Q03923341A

NPTF TERMINATION ENDS
 TO ANSI B 1.20.3

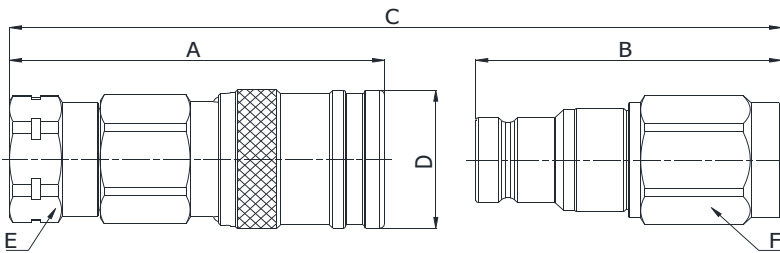

SIZE			PART NUMBER		THREAD	DIMENSIONS mm							
DN	Inch	Dash	Female coupling	Male coupling		A	B	C	D	E	F		
10	3/8"	-06	Q04123341A-06-06	Q03923341A-06-06	3/8" NPTF	78.3	63.8	A+B-15,9	ø32	27	27		
12.5	1/2"	-08	Q04123341A-08-08	Q03923341A-08-08	1/2" NPTF	88.5	71.3	A+B-17,1	ø38	36	36		
16	5/8"	-10	Q04123341A-10-12	Q03923341A-10-12	3/4" NPTF	94.6	76.4	A+B-17,6	ø42	36	36		
20	3/4"	-12	Q04123341A-12-12	Q03923341A-12-12	3/4" NPTF	108	89.8	A+B-21.7	ø48	41	41		
25	1"	-16	Q04123341A-16-16	Q03923341A-16-16	1" NPTF	119.4	92.1	A+B-22,9	ø55	50	50		



STAINLESS STEEL SCREW TYPE HEAVY DUTY

Pressure Drop

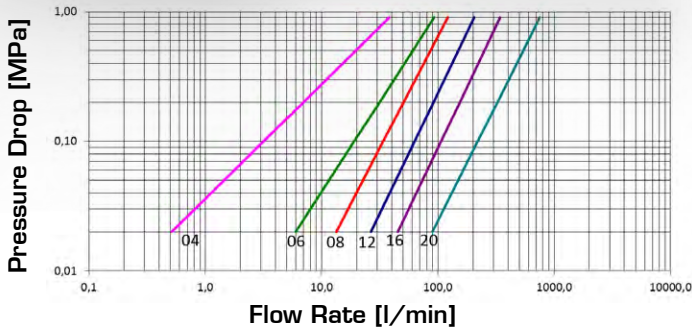

Pressure Drop

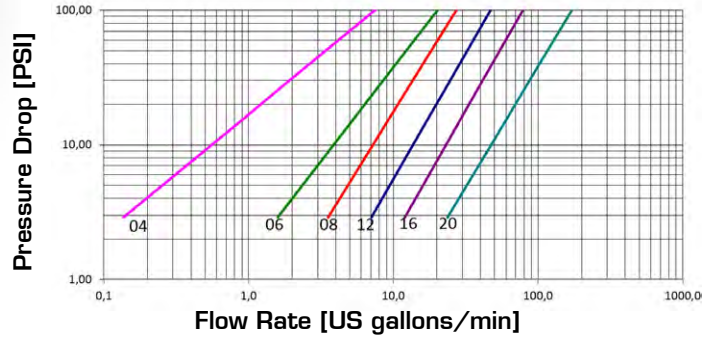

Q.SAFE 460

TECHNICAL DATA

SIZE			MPa		FLOW RATE		OIL SPILLAGE		MINIMUM BURST PRESSURE						CONNECTION / DISCONNECTION UNDER PRESSURE
DN	inch	Dash	MPa	PSI	l/min	US GPM	cc.	cubic inch	Male		Female		M & F		
									MPa	PSI	MPa	PSI	MPa	PSI	
6	1/4"	04	50	7250	10	2.6	0.4	0.024	220	31900	350	50750	350	50750	Not allowed
10	3/8"	06	35	5075	31	8.2	1.5	0.092	150	21750	180	26100	180	26100	Not allowed
12.5	1/2"	08	35	5075	51	13.5	2	0.134	140	20300	220	31900	250	36250	Not allowed
20	3/4"	12	32	4640	92	24.3	4	0.244	130	18850	220	31900	200	29000	Not allowed
25	1"	16	32	4640	156	41.2	7.5	0.458	130	18850	180	26100	180	26100	Not allowed
31	1 1/4"	20	30	4350	325	85.9	15	0.916	120	17400	150	21750	160	23200	Not allowed

The rated flow represents the normal operating condition. The maximum recommended flow rate is equal to 1.5 times the rated flow

PRODUCT DESCRIPTION

- Screw-on connection/disconnection system
- Sleeve with hexagon area internal components reinforced, made in steel
- Hardened valve bodies
- Three-part poppet valve with a moulded shaped seal
- Mechanical backstop to prevent partial enclosures of valves due to peaks and reverse flow
- Interchangeable with other products and widely used on the market
- Accessories (plugs and caps) and spare part kits available
- Wide range of termination ends
- FKM (VITON) seal

MATERIAL

Couplings in steel with some stressed area hardened.
Carbonitrided valve, springs in C98 steel, FKM (VITON) seal and back-up ring in PTFE

WORKING TEMPERATURE

-25°C up to +200°C

SAFETY FACTOR

4:1 for dynamic pressures

IMPULSE PRESSURES

200,000 cycles (connected and disconnected conditions) at 120% of the rated one (freq. 1Hz)

TEST SPECIFICATIONS

ISO 18869

ASSEMBLY INSTRUCTIONS

RECOMMENDED TIGHTENING TORQUES

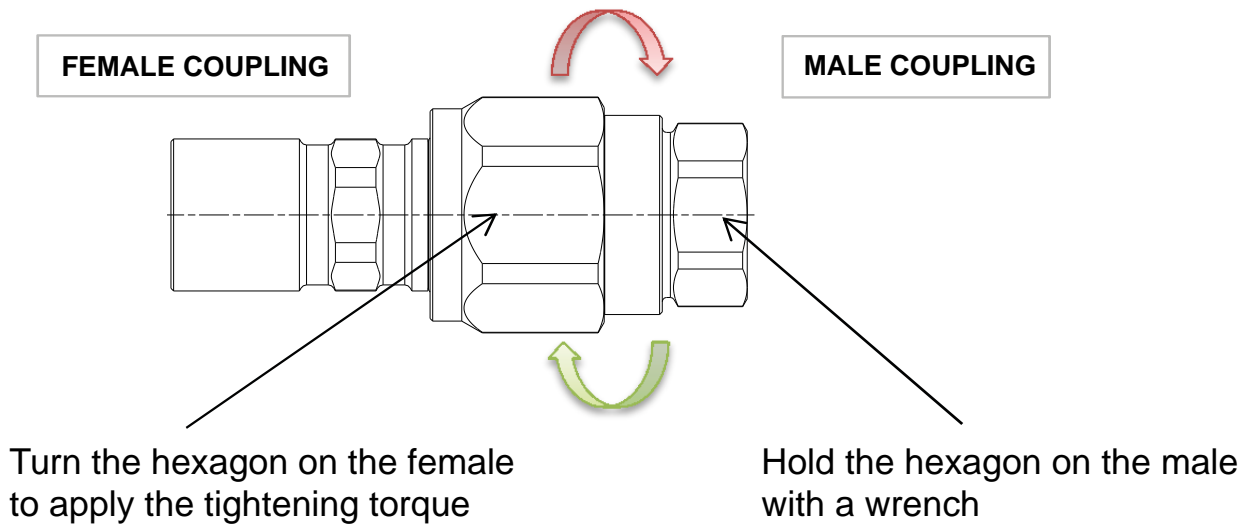

SIZE			TIGHTENING TORQUE
DN	Inch	Dash	Nm
6	1/4"	-04	50
10	3/8"	-06	70
12.5	1/2"	-08	100
19	3/4"	-12	150
25	1"	-16	250
31	1-1/4"	-20	400

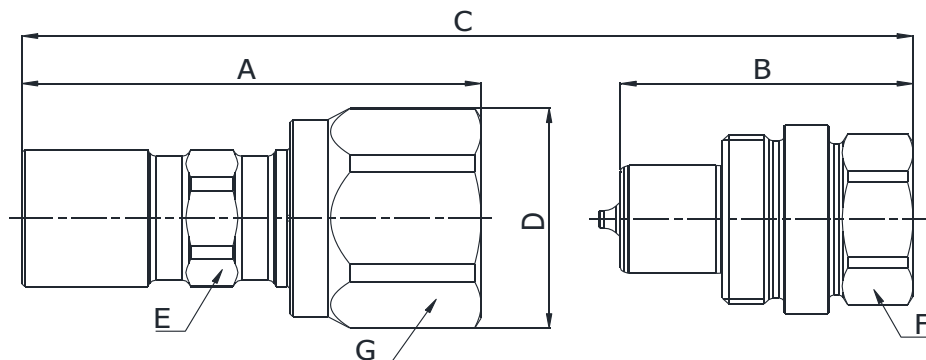

Q05423041A
Q05323041A

BSP TERMINATION ENDS
TO DIN 3852 X TYPE

SIZE			PART NUMBER		THREAD	DIMENSIONS mm						
DN	Inch	Dash	Female coupling	Male coupling		A	B	C	D	E	F	G
6.3	1/4"	-04	Q05423041A-04-04	Q05323041A-04-04	1/4"	63	42.2	A+B-20,4	ø35	19	22	32
10	3/8"	-06	Q05423041A-06-06	Q05323041A-06-06	3/8"	72.5	46.2	A+B-25,9	ø38,5	22	27	35
12.5	1/2"	-08	Q05423041A-08-08	Q05323041A-08-08	1/2"	82.1	54.4	A+B-27,3	ø45	27	32	41
20	3/4"	-12	Q05423041A-12-12	Q05323041A-12-12	3/4"	93.7	61.4	A+B-31,9	ø55	35	41	50
25	1"	-16	Q05423041A-16-16	Q05323041A-16-16	1"	105.8	68.3	A+B-37	ø66	41	50	60
31.5	1.1/4"	-20	Q05423041A-20-20	Q05323041A-20-20	1.1/4"	131.9	82	A+B-53,9	ø88	55	70	80

Q.SAFE
462

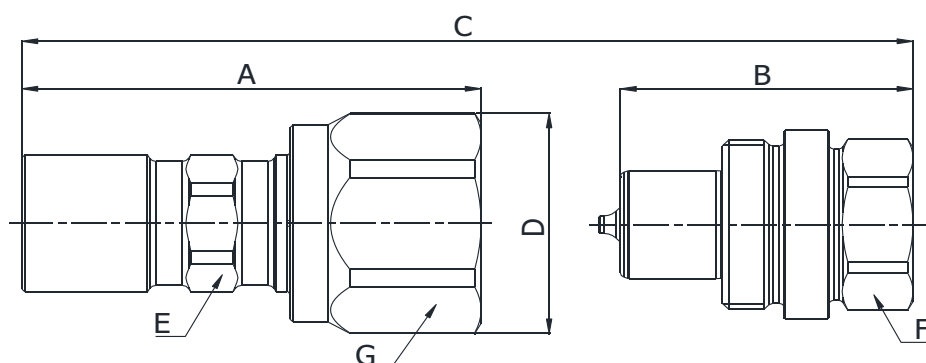

Q05423341A
Q05323341A

NPTF TERMINATION END
TO ANSI B 1.20.3

SIZE			PART NUMBER		THREAD	DIMENSIONS mm						
DN	Inch	Dash	Female coupling	Male coupling		A	B	C	D	E	F	G
6.3	1/4"	-04	Q05423341A-04-04	Q05323341A-04-04	1/4" NPTF	63	42.2	A+B-20,4	ø35	19	22	32
10	3/8"	-06	Q05423341A-06-06	Q05323341A-06-06	3/8" NPTF	72.5	46.2	A+B-25,9	ø38,5	22	27	35
12.5	1/2"	-08	Q05423341A-08-08	Q05323341A-08-08	1/2" NPTF	82.1	54.4	A+B-27,3	ø45	27	32	41
20	3/4"	-12	Q05423341A-12-12	Q05323341A-12-12	3/4" NPTF	93.7	61.4	A+B-31,9	ø55	35	41	50
25	1"	-16	Q05423341A-16-16	Q05323341A-16-16	1" NPTF	105.8	68.3	A+B-37	ø66	41	50	60
31.5	1.1/4"	-20	Q05423341A-20-20	Q05323341A-20-20	1.1/4" NPTF	131.9	82	A+B-53,9	ø88	55	70	80

DHI TYPE ISO A POPPET VALVE



Pressure Drop

Pressure Drop

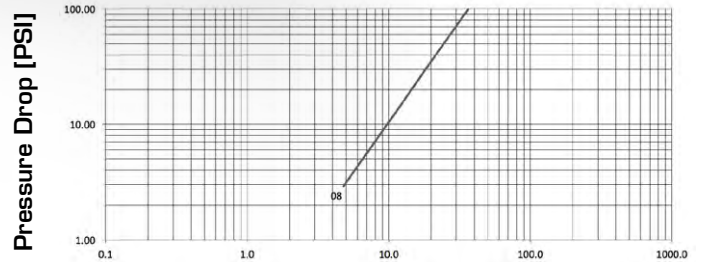
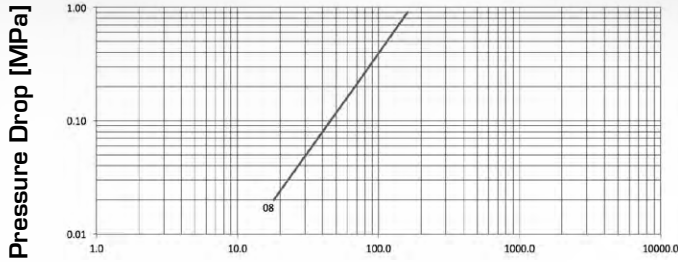

Flow Rate [l/min]

Flow Rate [US gallons/min]

TECHNICAL DATA

SIZE			MPa		FLOW RATE		N		OIL SPILLAGE Connection/Disconnection		MINIMUM BURST PRESSURE						CONNECTION/DISCONNECTION UNDER PRESSURE	
DN	inch	Dash	MPa	PSI	l/min	US GPM	N	lb.	cc.	cubic inch	Male		Female		M & F		Not allowed	
										MPa	PSI	MPa	PSI	MPa	PSI			
12.5	½	08	30	4350	68	18.0	80	18.0	1.8	0.110	125	18125	150	21750	150	21750	Not allowed	

The rated flow represents the normal operating condition. The maximum recommended flow rate is equal to 1.5 times the rated flow

PRODUCT DESCRIPTION

- Dimensional and performance requirements conform to ISO 7241-1 series A, ensuring worldwide interchangeability
- Connect by pulling back the sleeve (with female ISO A)
- Positive connection by the locking ball system
- Shut-off poppet valve provides an effective hydraulic sealing
- When female bulkhead is mounted on the outside sleeve (PUSH-PULL), the coupling ensures breakaway features according to ISO 5675

MATERIAL

Female coupling in steel with some hardened areas, in correspondence to the most stressed points. Male couplings in high grade carbon steel. Carbonitrided valve and sleeve, springs in C98 steel, seals in NBR (other materials available on request) and back-up ring in PTFE

WORKING TEMPERATURE

-22°F up to +230°F (-30°C up to +110°C)
For other temperatures, the coupling may be assembled with the specific seals

SAFETY FACTOR

4:1 for dynamic pressures

IMPULSE PRESSURES

100,000 cycles at 133% of the rated one (freq. 1Hz)

TEST SPECIFICATIONS

ISO 18869



Quick release couplings DHI maintenance without flexible hose replacement

Q30811MF1A Q30211MF1A

ISO A COUPLING
MULTIFIT INSERT

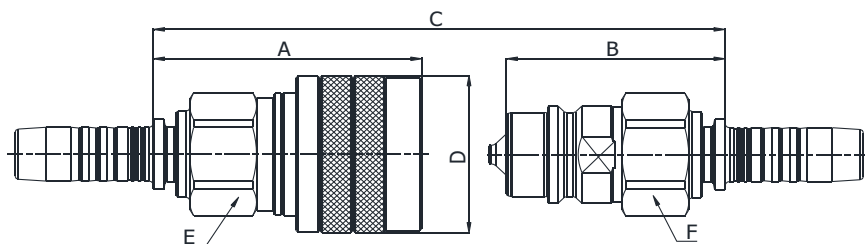

SIZE			PART NUMBER		HOSE BORE			DIMENSIONS mm					
DN	Inch	Dash	Female coupling	Male coupling	DN	Inch	Dash	A	B	C	D	E	F
12.5	1/2"	-08	Q30811MF1A-08-04	Q30211MF1A-08-04	6	1/4"	-04	62.5	51.3	A+B-21,8	ø38	27	27
12.5	1/2"	-08	Q30811MF1A-08-05	Q30211MF1A-08-05	8	5/16"	-05	62.5	51.3	A+B-21,8	ø38	27	27
12.5	1/2"	-08	Q30811MF1A-08-06	Q30211MF1A-08-06	10	3/8"	-06	62	50.8	A+B-21,8	ø38	27	27
12.5	1/2"	-08	Q30811MF1A-08-08	Q30211MF1A-08-08	12	1/2"	-08	60.4	49.2	A+B-21,8	ø38	27	27



DHI TYPE ISO A PUSH-PULL POPPET VALVE

Pressure Drop

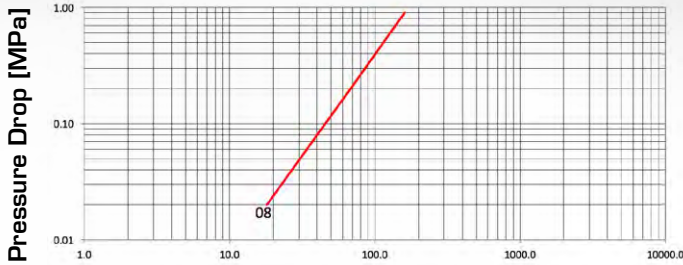

Flow Rate [l/min]

Pressure Drop

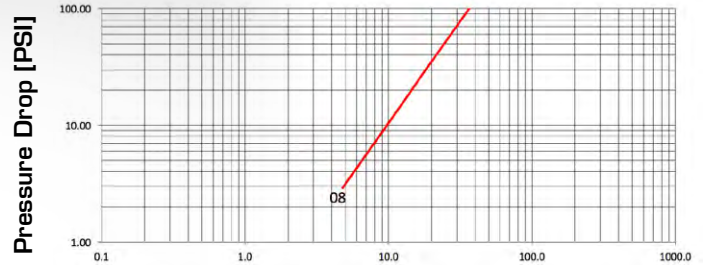

Flow Rate [US gallons/min]

TECHNICAL DATA

SIZE		WORKING PRESSURE [Dynamic]		RATED FLOW at 0.2 MPa of pressure drop		CONNECTION EFFORT		OIL SPILLAGE Connection/ Disconnection		MINIMUM BURST PRESSURE				CONNECTION/ DISCONNECTION UNDER PRESSURE	
DN	inch	MPa	PSI	l/min	US GPM	N	lb.	cc.	cubic inch	Male		M & F			
										MPa	PSI	MPa	PSI		
12.5	½	08	30	4350	68	18.0	110	244	2	0.122	140	20300	140	20300	Not allowed

The rated flow represents the normal operating condition. The maximum recommended flow rate is equal to 1.5 times the rated flow

PRODUCT DESCRIPTION

- Female coupling designed for agriculture applications, connectable with ISO 7241-1 series A male couplings
- PUSH-PULL connection and disconnection system, in case of bulkhead mounting on the external sleeve
- Break-away function according to ISO 5675 (in case of bulkhead mounting on the external sleeve)
- Positive connection by latching balls system
- Shut-off by poppet valve
- High resistant materials
- Dimensions and performances according to ISO 7241-1 series A

MATERIAL

Female couplings in steel with some hardened areas, in correspondence to the most stressed points. Carbonitrided valve and sleeve, springs in C98 steel, latching balls in high resistance 100 C6 steel, seals in NBR (other materials on request) and back-up ring in PTFE

WORKING TEMPERATURE

-22°F up to +230°F (-30°C up to +110°C)
For other temperatures, the coupling is assembled with specific seals

SAFETY FACTOR

4:1 for dynamic pressures

IMPULSE PRESSURES

100,000 cycles at 133% of the rated one (freq. 1Hz)

TEST SPECIFICATIONS

ISO 18869

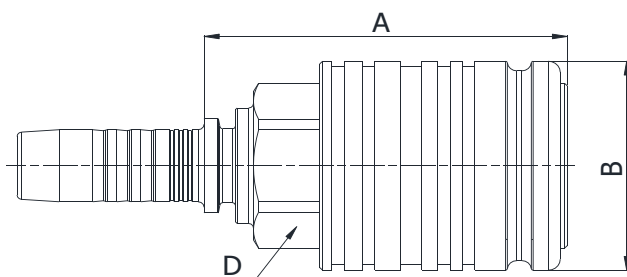

Q31311MF1A

FEMALE PUSH PULL COUPLING
MULTIFIT INSERT

SIZE			PART NUMBER	HOSE BORE			DIMENSIONS mm					
DN	Inch	Dash	Female coupling	DN	Inch	Dash	A	B	D			
12.5	1/2"	-08	Q31311MF1A-08-04	6	1/4"	-04	62.5	ø38	27			
12.5	1/2"	-08	Q31311MF1A-08-05	8	5/16"	-05	62.5	ø38	27			
12.5	1/2"	-08	Q31311MF1A-08-06	10	3/8"	-06	62	ø38	27			
12.5	1/2"	-08	Q31311MF1A-08-08	12	1/2"	-08	60.4	ø38	27			

Q.SAFE 466

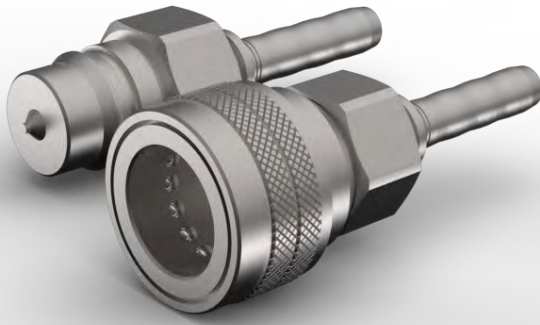

DHI TYPE ISO B POPPET VALVE

Pressure Drop

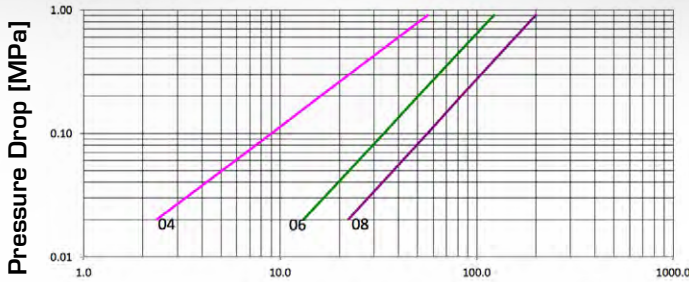

Flow Rate [l/min]

Pressure Drop

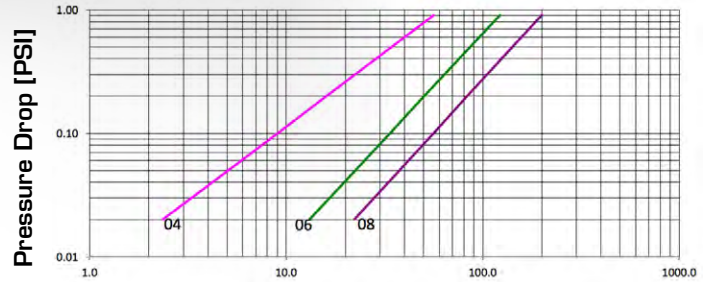

Flow Rate [US gallons/min]

TECHNICAL DATA

SIZE			WORKING PRESSURE [Dynamic]		RATED FLOW at 0.2 MPa of pressure drop		CONNECTION EFFORT		OIL SPILLAGE Connection/Disconnection		MINIMUM BURST PRESSURE						CONNECTION/DISCONNECTION UNDER PRESSURE
DN	inch	Dash	MPa	PSI	l/min	US GPM	N	lb.	cc.	cubic inch	Male		Female		M & F		
			MPa	PSI							MPa	PSI	MPa	PSI	MPa	PSI	
6.3	1/4	04	40	5800	16	4.3	40	9.0	0.8	0.049	180	26100	190	27550	165	23925	Not allowed
10	3/8	06	35	5075	51	13.5	40	9.0	1.5	0.092	145	21025	160	23200	160	23200	Not allowed
12.5	1/2	08	35	5075	84	22.0	70	15.7	2.5	0.153	145	21025	145	21025	160	23200	Not allowed

The rated flow represents the normal operating condition. The maximum recommended flow rate is equal to 1.5 times the rated flow

PRODUCT DESCRIPTION

- Reference series for all industrial applications
- Simple connection and disconnection by pulling back the sleeve
- Positive, quick connection of the male into the female by latching the ball system
- Shut-off by poppet valve
- High resistant materials
- Interchangeable according to ISO 7241-1 series B

MATERIAL

Female couplings in steel, with some hardened areas, in correspondence to the most stressed points. Male couplings in high grade carbon steel hardened. Springs in C98 steel, seals in NBR (other materials on request) and back-up ring in PTFE

WORKING TEMPERATURE

-22°F up to +230°F (-30°C up to +110°C)
For other temperatures, the quick coupling is assembled with specific seals

SAFETY FACTOR

4:1 for dynamic pressures

IMPULSE PRESSURES

Withstands 100,000 cycles of impulse pressure at 133% of the rated one (freq. 1Hz)

TEST SPECIFICATIONS

ISO 18869

Q32411MF1A Q32111MF1A

ISO B COUPLINGS
MULTIFIT INSERT

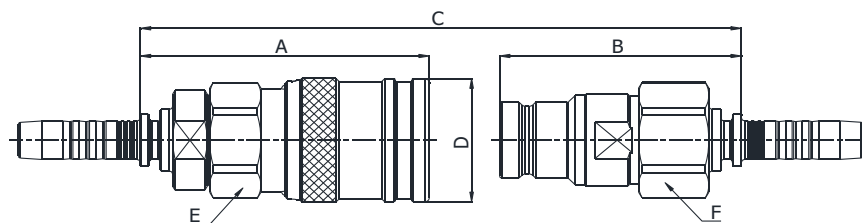

SIZE			PART NUMBER		HOSE BORE			DIMENSIONS mm					
DN	Inch	Dash	Female coupling	Male coupling	DN	Inch	Dash	A	B	C	D	E	F
6.3	1/4"	-04	Q32411MF1A-04-06	Q32111MF1A-04-06	10	3/8"	-06	56	45.1	A+B-21,2	ø28	19	19
10	3/8"	-06	Q32411MF1A-06-06	Q32111MF1A-06-06	10	3/8"	-06	65.2	51.3	A+B-24,4	ø35	22	22
12.5	1/2"	-08	Q32411MF1A-08-08	Q32111MF1A-08-08	12	1/2"	-08	72	53.7	A+B-27,2	ø42	27	27
12.5	1/2"	-08	Q30811MF1A-08-08	Q30211MF1A-08-08	12	1/2"	-08	60.4	49.2	A+B-21,8	ø38	27	27

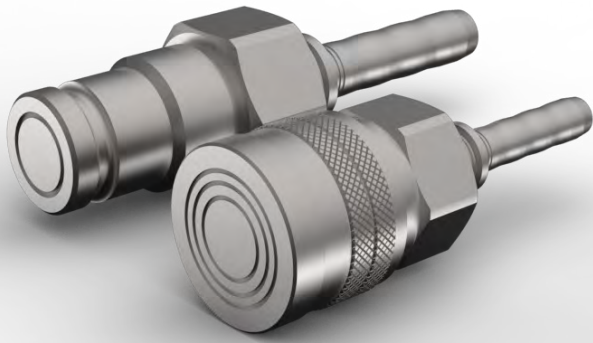

DHI TYPE FLAT FACE

Pressure Drop

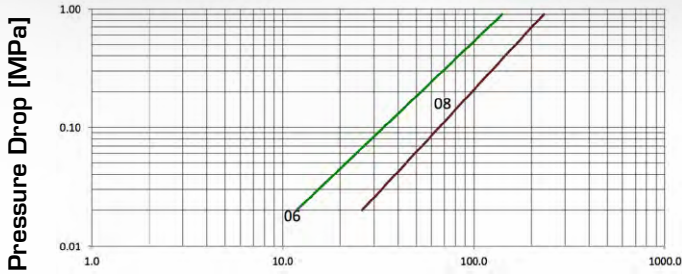

Flow Rate [l/min]

Pressure Drop

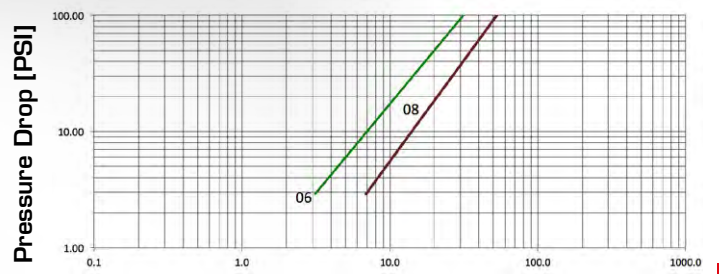

Flow Rate [US gallons/min]

TECHNICAL DATA

SIZE			MPa				FLOW RATE		N		Oil Spillage		MINIMUM BURST PRESSURE						CONNECTION WITH FEMALE UNDER PRESSURE (MALE AT 0 MPa)
DN	inch	Dash	MPa	PSI	MPa	PSI	l/min	US GPM	N	lb.	cc.	cubic inch	Male		Female		M & F		
			MPa	PSI	MPa	PSI							MPa	PSI	MPa	PSI	MPa	PSI	
10	3/8	06	35	5075	25	3625	54	14.3	130	29.2	0.007	0.0004	135	19575	125	18125	140	20300	Allowed up to 6 MPa
12.5	1/2	08	35	5075	25	3625	86	22.7	150	33.7	0.008	0.0005	120	17400	110	15950	145	21025	Allowed up to 4 MPa

Connection with Male under pressure not allowed; Disconnection under pressure not allowed
 The rated flow represents the normal operating condition. The maximum recommended flow rate is equal to 1.5 times the rated flow

PRODUCT DESCRIPTION

- Connection is made by pushing the male coupling and disconnection by pulling back the sleeve of the female
- Flat mating surfaces easily wiped clean to prevent contamination and spillage during connection/disconnection
- Stainless steel springs in the female coupling
- Interchangeability according to ISO 16028 and HTMA standards

MATERIAL

Female and male coupling in steel, with some stressed tempered or carbonitrided areas. Springs in AISI and C98 steel, seals in polyurethane NBR. Other materials (VITON, EPDM or any others) on request.

WORKING TEMPERATURE

-22°F up to +230°F (-30°C up to +110°C)
 For other temperatures the coupling is assembled with the specified seals

SAFETY FACTOR

4:1 for dynamic pressures

IMPULSE PRESSURES

100,000 cycles at 133% of the rated one (freq. 1Hz) in disconnected conditions.
 1,000,000 cycles at 120% of rated one (freq. 1Hz) in connected conditions.

TEST SPECIFICATIONS

ISO 18869

Q34111MF1A Q33911MF1A

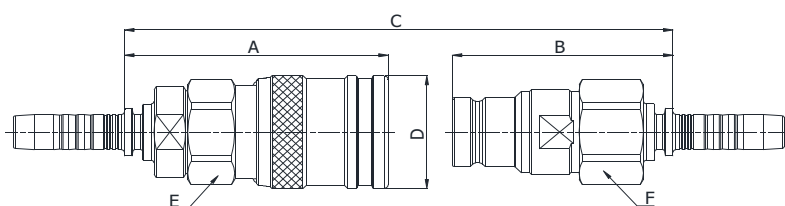

FLAT FACE COUPLING
MULTIFIT INSERT

SIZE			PART NUMBER		HOSE BORE			DIMENSIONS mm					
DN	Inch	Dash	Female coupling	Male coupling	DN	Inch	Dash	A	B	C	D	E	F
10	3/8"	-06	Q34111MF1A-06-06	Q33911MF1A-06-06	10	3/8"	-06	69.7	58.3	A+B-15,9	ø32	27	27
10	3/8"	-06	Q34111MF1A-06-08	Q33911MF1A-06-08	12	1/2"	-08	69.6	56.7	A+B-15,9	ø32	27	27
12.5	1/2"	-08	Q34111MF1A-08-08	Q33911MF1A-08-08	12	1/2"	-08	78.9	66.7	A+B-17.1	ø38	34	34
12.5	1/2"	-08	Q34111MF1A-08-12	Q33911MF1A-08-12	19	3/4"	-12	75.8	65.1	A+B-17.1	ø38	34	34

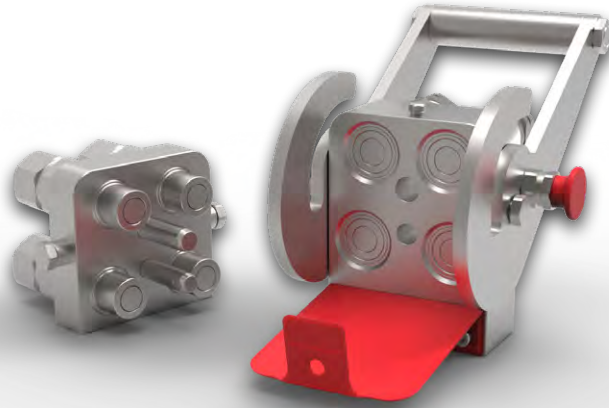

FLAT FACE MULTI-CONNECTOR

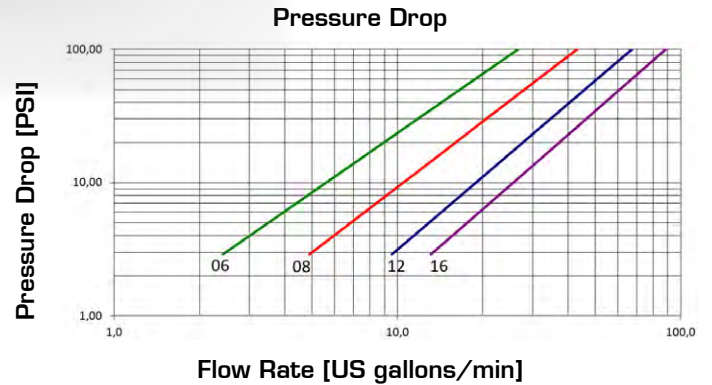
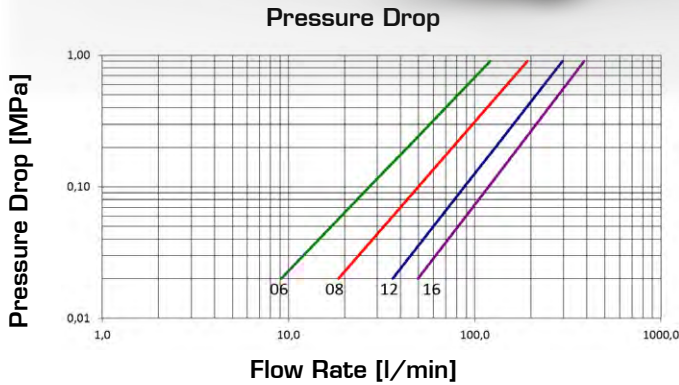

TECHNICAL DATA

SIZE		WORKING PRESSURE CONNECTED [Dynamic]		WORKING PRESSURE DISCONNECTED [Dynamic]		RATED FLOW at 0.2 MPa of pressure drop		OIL SPILLAGE Connection/Disconnection		MINIMUM BURST PRESSURE						CONNECTION/DISCONNECTION UNDER PRESSURE	
DN	inch	Dash	MPa	PSI	MPa	PSI	l/min	US GPM	cc.	cubic inch	Male		Female		M & F		
			MPa	PSI	MPa	PSI					MPa	PSI	MPa	PSI	MPa	PSI	
10	3/8"	06	35	5,075	35	5,075	44	11.6	0.007	0.0004	170	24,650	140	20,300	180	26,100	Allowed
12.5	1/2"	08	35	5,075	35	5,075	76	20.1	0.008	0.0005	170	24,650	140	20,300	180	26,100	Allowed
19	3/4"	12	35	5,075	35	5,075	129	34.1	0.009	0.0005	140	20,300	140	20,300	160	23,200	Allowed
25	1"	16	35	5,075	35	5,075	172	45.4	0.02	0.0012	160	23,200	150	21,750	160	23,200	Allowed

The rated flow represents the normal operating condition. The maximum recommended flow rate is equal to 1.5 times the rated flow

PRODUCT DESCRIPTION

- Flat mating surfaces easily wiped clean to prevent contamination and spillage during connection/disconnection
- Lever provides simultaneous connection / disconnection of couplings
- Positive, quick connection of the male into the female by the lever
- Shut-off by flat valve
- 1,000,000 cycles at 120% of rated (freq. 1Hz)

MATERIAL

Female and male coupling in steel, with springs in AISI and C98 steel, seals in polyurethane and NBR. Other materials (VITON, EPDM or any others) on request

WORKING TEMPERATURE

-22°F up to +230°F (-30°C up to +110°C)
For other temperatures the coupling is assembled with the specified seals

SAFETY FACTOR

4:1 for dynamic pressures

IMPULSE PRESSURES

1,000,000 cycles at 120% of rated one (freq. 1Hz) in connected and disconnected conditions.

TEST SPECIFICATIONS

ISO 18869

Q401 SERIES

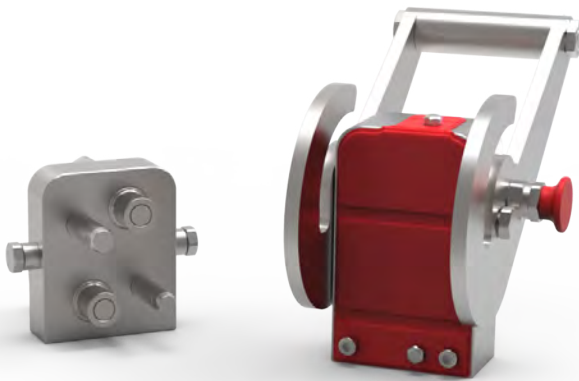

2 LINE MULTI-COUPLING
DOUBLE-SIDED LEVER
LOCKING POSITION: LEFT *

* Right hand locking available on request
** Plate adaptor for frontal fixing available

Q.SAFE
472

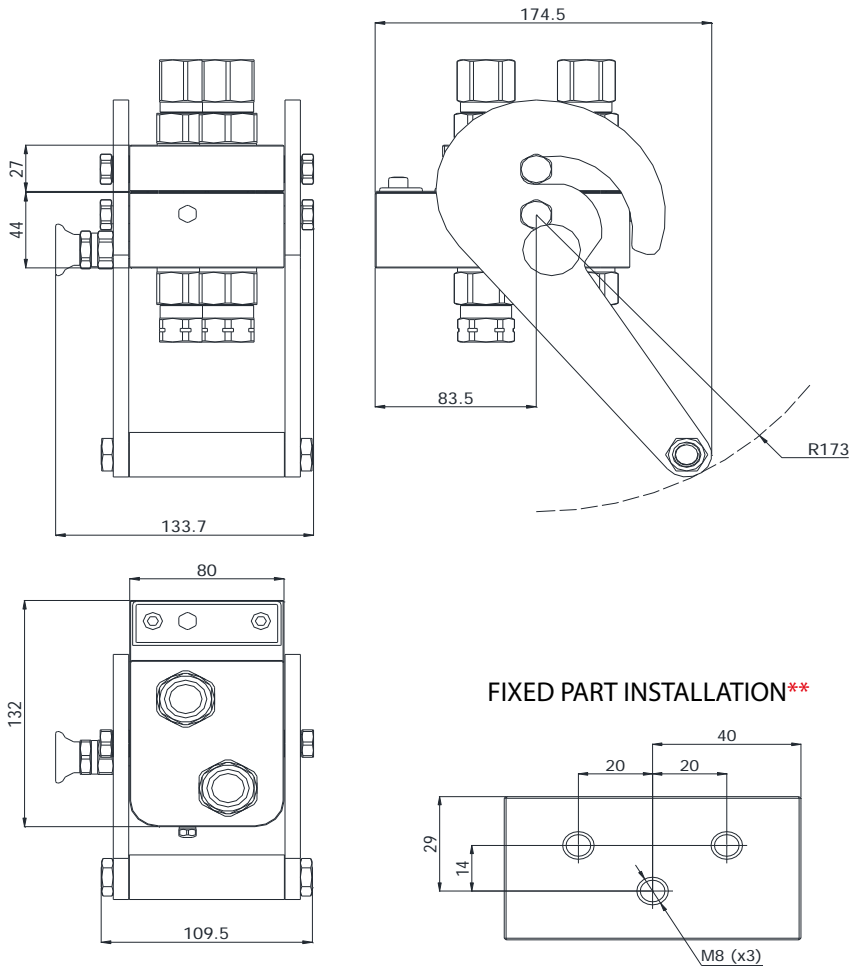

MULTI-COUPLING					TERMINATION END *		
PART NUMBER		SIZE			LINES	DESCRIPTION	THREAD
Fixed	Mobile	DN	Inch	Dash			
Q401BOF-041-06	Q401BOM-041-06	10	3/8"	-06	2	BSP FEMALE DIN3852-2 TYPE X	3/8" BSP
Q401BOF-041-08	Q401BOM-041-08	10	3/8"	-06	2	BSP FEMALE DIN3852-2 TYPE X	1/2" BSP

* Alternative termination ends can be provided - please ask your sales rep for details

Q402 SERIES

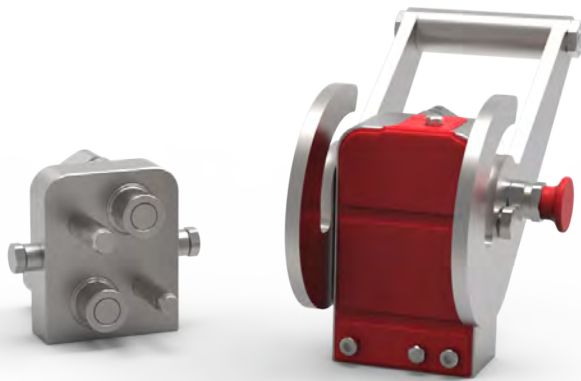

2 LINE MULTI-COUPLING
 DOUBLE-SIDED LEVER
 LOCKING POSITION: LEFT *

* Right hand locking available on request
 ** Plate adaptor for frontal fixing available

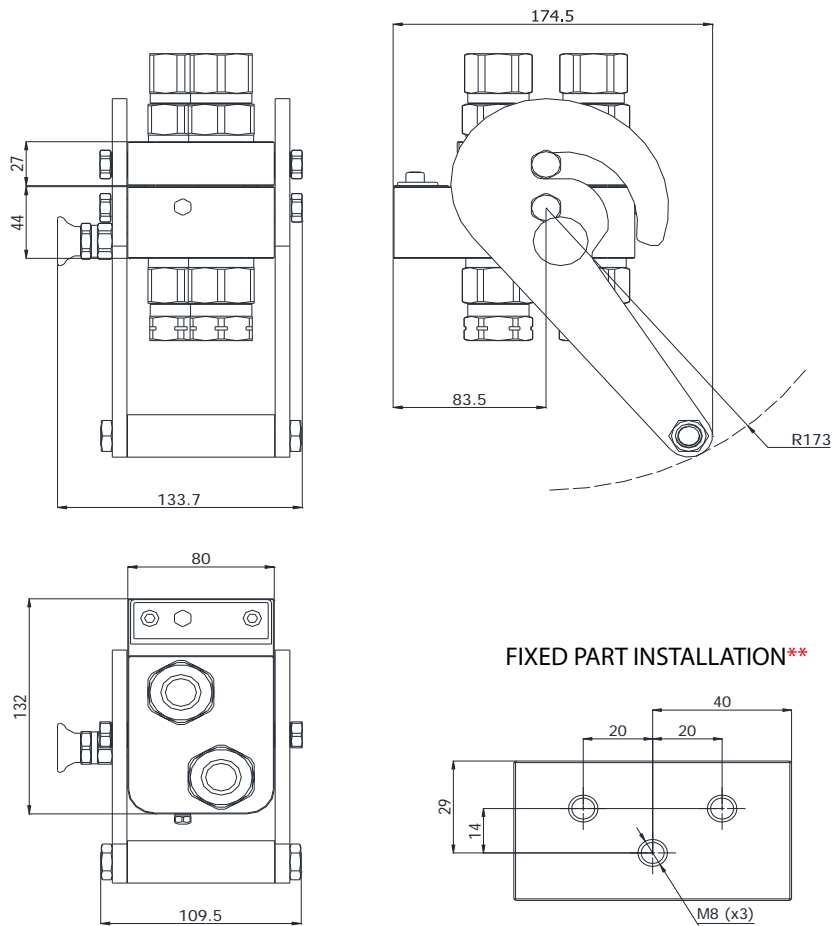

473 Q.SAFE

MULTI-COUPLING					TERMINATION END *		
PART NUMBER		SIZE			LINES	DESCRIPTION	THREAD
Fixed	Mobile	DN	Inch	Dash			
Q402B0F-041-08	Q402B0M-041-08	12.5	1/2"	-08	2	BSP FEMALE DIN3852-2 TYPE X	1/2" BSP
Q402B0F-041-12	Q402B0M-041-12	12.5	1/2"	-08	2	BSP FEMALE DIN3852-2 TYPE X	3/4" BSP

* Alternative termination ends can be provided - please ask your sales rep for details

Q403 SERIES

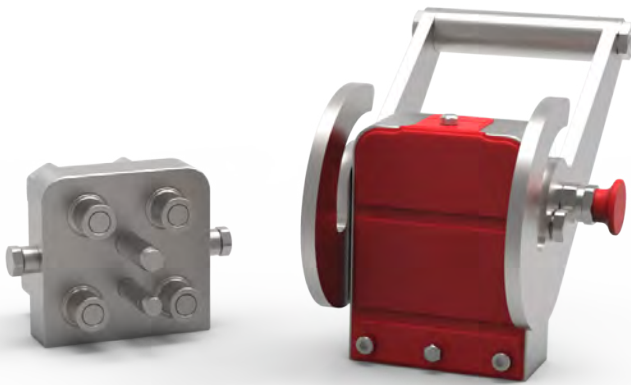

4 LINE MULTI-COUPLING
DOUBLE-SIDED LEVER
LOCKING POSITION: LEFT *

* Right hand locking available on request
** Plate adaptor for frontal fixing available

Q.SAFE
474

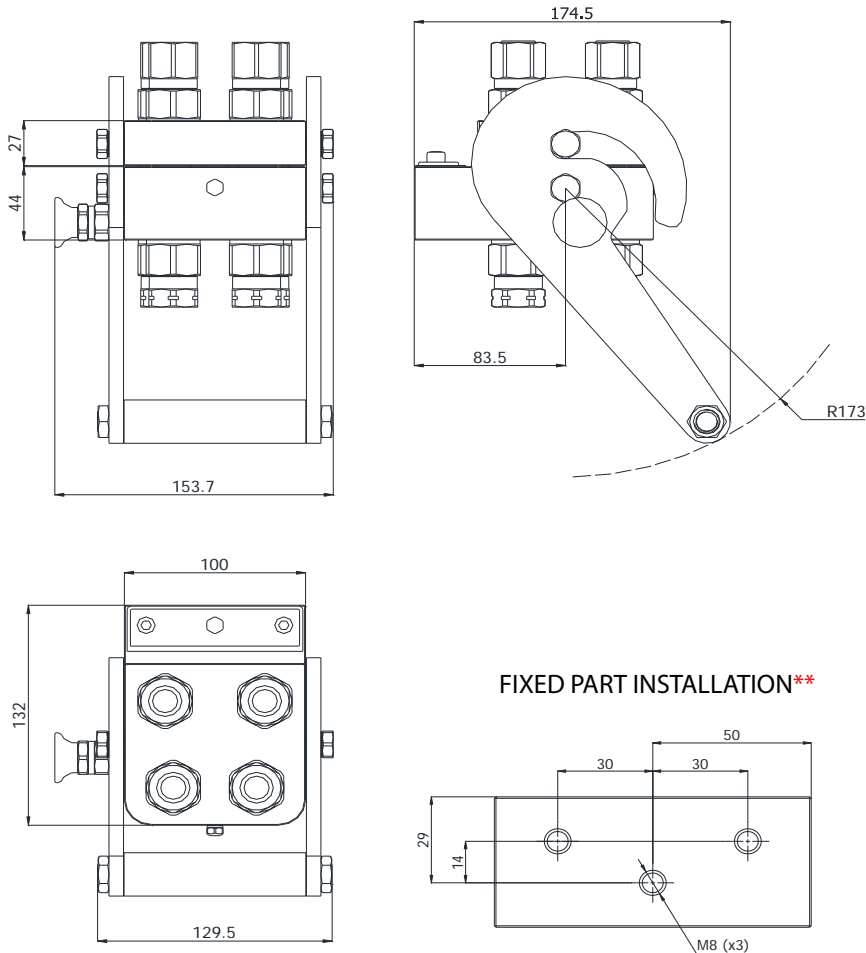

MULTI-COUPLING					TERMINATION END *		
PART NUMBER		SIZE			LINES	DESCRIPTION	THREAD
Fixed	Mobile	DN	Inch	Dash			
Q403DOF-041-06	Q403DOM-041-06	10	3/8"	-06	4	BSP FEMALE DIN3852-2 TYPE X	3/8" BSP
Q403DOF-120-20	Q403DOM-120-20	10	3/8"	-06	4	METRIC MALE ISO 8434-1 S SERIES	M20x1.5

* Alternative termination ends can be provided - please ask your sales rep for details

Q404 SERIES

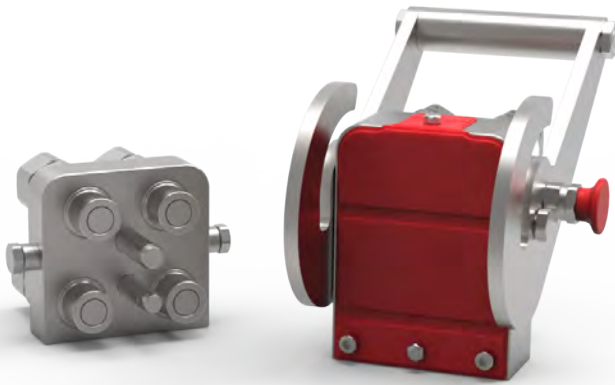

4 LINE MULTI-COUPLING
 DOUBLE-SIDED LEVER
 LOCKING POSITION: LEFT *

* Right hand locking available on request
 ** Plate adaptor for frontal fixing available

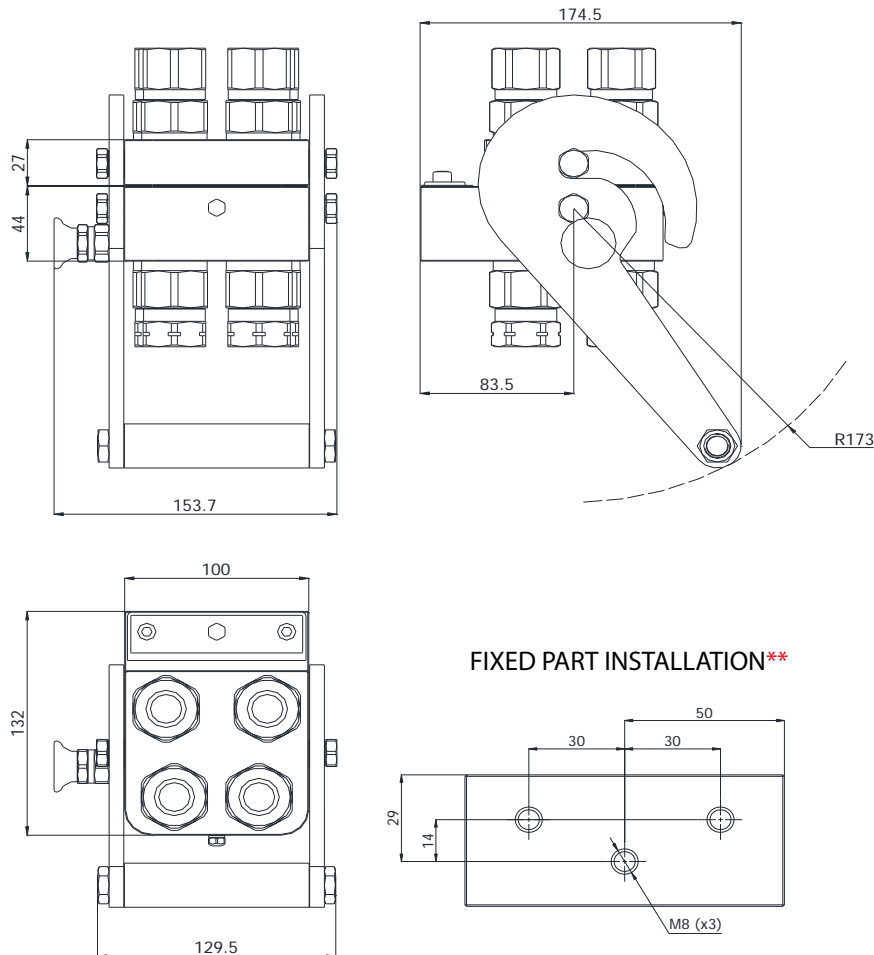

475 Q.SAFE

MULTI-COUPLING					TERMINATION END *		
PART NUMBER		SIZE			LINES	DESCRIPTION	THREAD
Fixed	Mobile	DN	Inch	Dash			
Q404D0F-041-08	Q404D0M-041-08	12.5	1/2"	-08	4	BSP FEMALE DIN3852-2 TYPE X	1/2" BSP
Q404C0F-AA	-	12.5	1/2"	-08	1	ORFS MALE ISO 8434-3	13/16"-16 UN
					2	ORFS MALE ISO 8434-3	1-3/16"-12 UN
-	Q404C0M-AA	12.5	1/2"	-08	1	BSP MALE ISO 8434-6	1/2" BSP
					2	BSP MALE ISO 8434-6	3/4" BSP

* Alternative termination ends can be provided - please ask your sales rep for details

Q405 SERIES

2 LINE MULTI-COUPLING
 SINGLE-SIDED LEVER
 LOCKING POSITION: LEFT

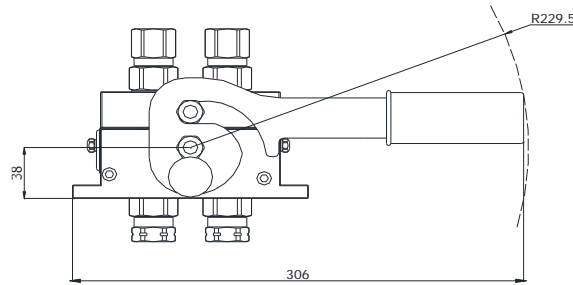
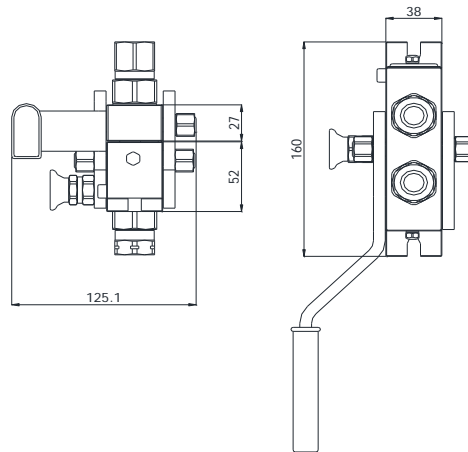
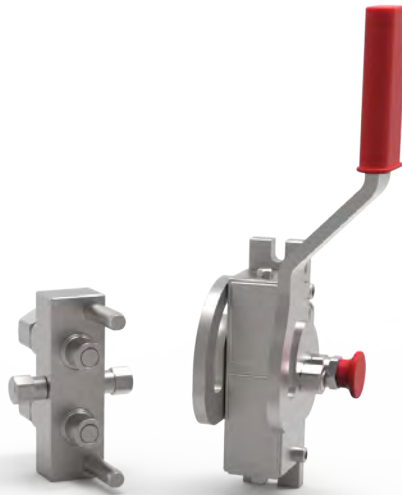

FIXED PART INSTALLATION**

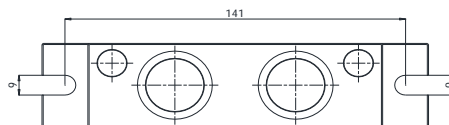

Q.SAFE
476

MULTI-COUPLING					TERMINATION END *		
PART NUMBER		SIZE			LINES	DESCRIPTION	THREAD
Fixed	Mobile	DN	Inch	Dash			
Q405B0F-041-06	Q405B0M-041-06	10	3/8"	-06	2	BSP FEMALE DIN3852-2 TYPE X	3/8" BSP

* Alternative termination ends can be provided - please ask your sales rep for details

Q406 SERIES

2+2 LINE MULTI-COUPLING
 DOUBLE-SIDED LEVER
 LOCKING POSITION: LEFT *

* Right hand locking available on request
 ** Plate adaptor for frontal fixing available

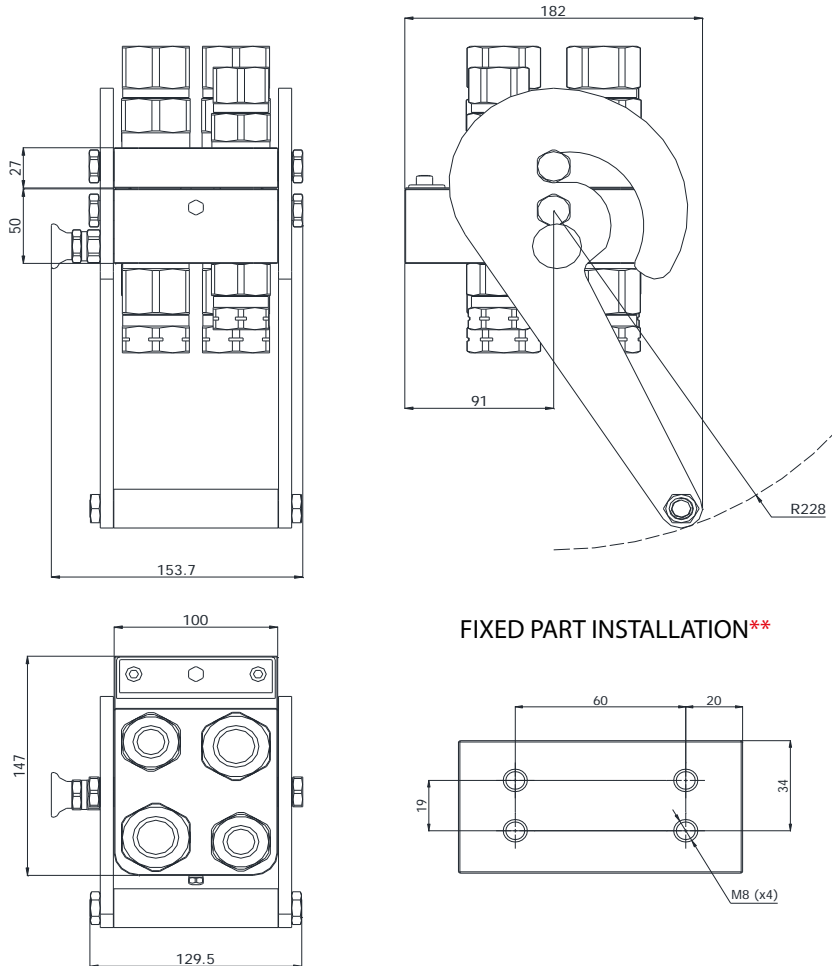
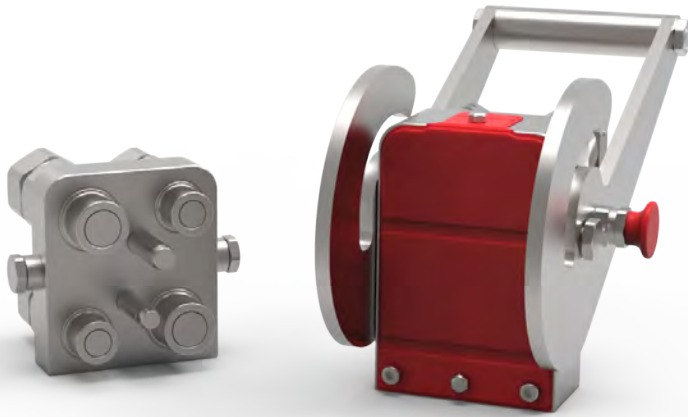

477 Q.SAFE

MULTI-COUPLING					TERMINATION END*		
PART NUMBER		SIZE			LINES	DESCRIPTION	THREAD
Fixed	Mobile	DN	Inch	Dash			
Q406D0F-AA	Q406D0M-AA	12.5	1/2"	-08	2	BSP FEMALE DIN3852-2 TYPE X	1/2" BSP
		19	3/4"	-12	2	BSP FEMALE DIN3852-2 TYPE X	3/4" BSP

* Alternative termination ends can be provided - please ask your sales rep for details

Q407 SERIES

6 LINE MULTI-COUPLING
 SINGLE-SIDED LEVER
 LOCKING POSITION: LEFT *

* Right hand locking available on request

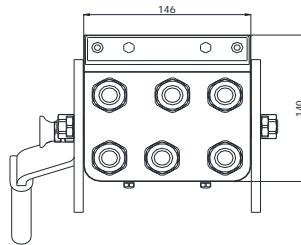
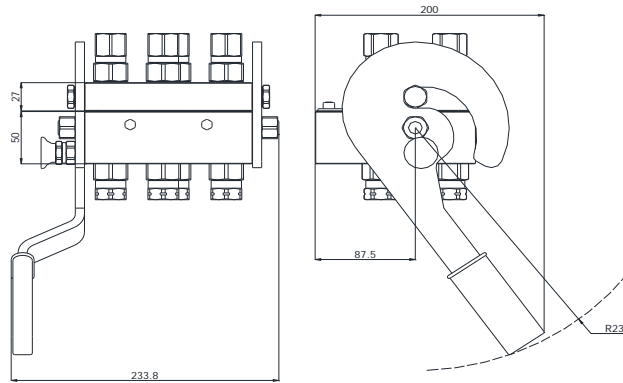
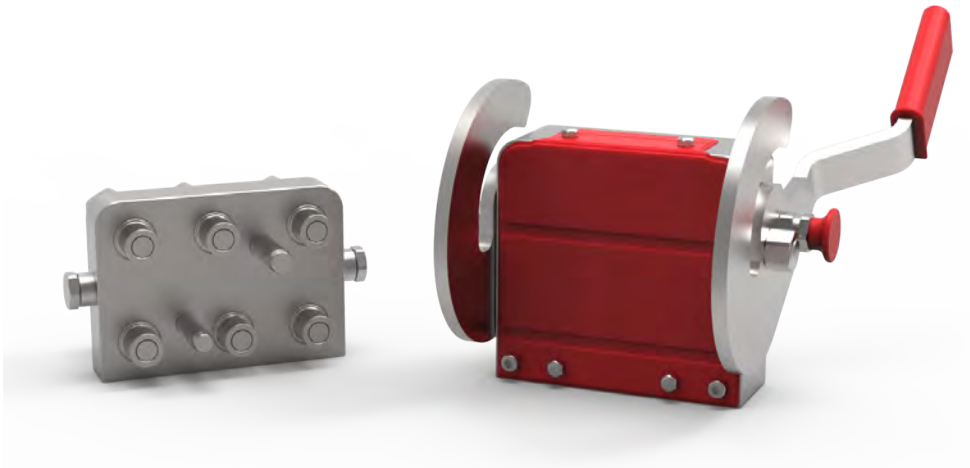

FIXED PART INSTALLATION**

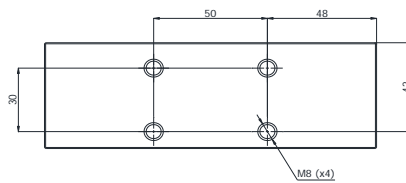

MULTI-COUPLING					TERMINATION END *		
PART NUMBER		SIZE			LINES	DESCRIPTION	THREAD
Fixed	Mobile	DN	Inch	Dash			
Q407F0F-041-06	Q407F0M-041-06	10	3/8"	-06	6	BSP FEMALE DIN3852-2 TYPE X	3/8" BSP
Q407E0F-041-06AA	Q407E0M-041-06AA	10	3/8"	-06	5	BSP FEMALE DIN3852-2 TYPE X	3/8" BSP

* Alternative termination ends can be provided - please ask your sales rep for details

Q.SAFE
478

Q408 SERIES

6 LINE MULTI-COUPLING
 SINGLE-SIDED LEVER
 LOCKING POSITION: LEFT *

* Right hand locking available on request

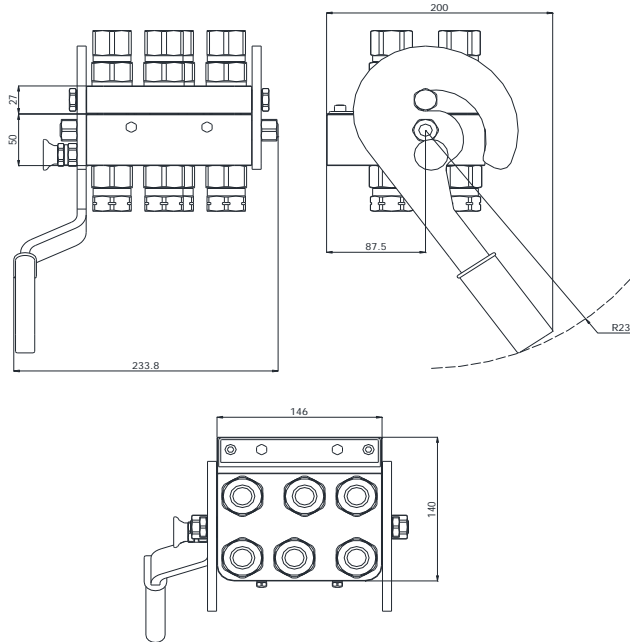
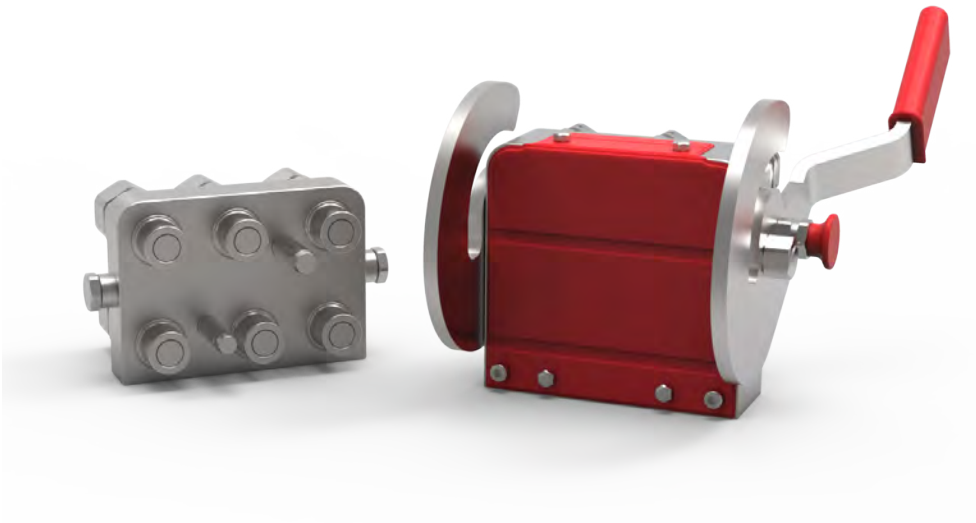

FIXED PART INSTALLATION**

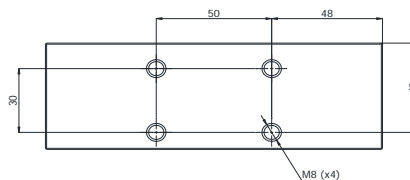

MULTI-COUPLING					TERMINATION END*		
PART NUMBER		SIZE			LINES	DESCRIPTION	THREAD
Fixed	Mobile	DN	Inch	Dash			
Q408F0F-041-08	Q408F0M-041-08	12.5	1/2"	-08	6	BSP FEMALE DIN3852-2 TYPE X	1/2" BSP

* Alternative termination ends can be provided - please ask your sales rep for details

Q409 SERIES

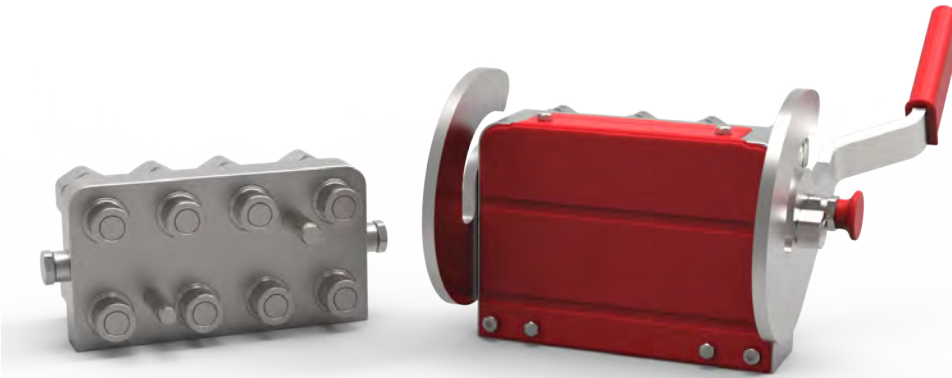

8 LINE MULTI-COUPLING
 SINGLE-SIDED LEVER
 LOCKING POSITION: LEFT *

* Right hand locking available on request

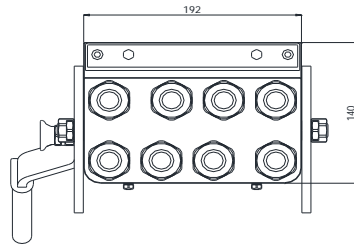
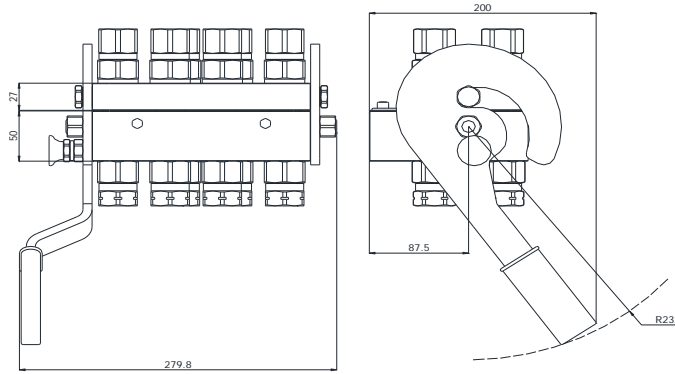

FIXED PART INSTALLATION**

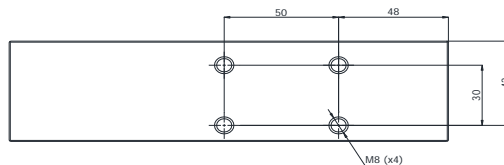

MULTI-COUPLING					TERMINATION END *		
PART NUMBER		SIZE			LINES	DESCRIPTION	THREAD
Fixed	Mobile	DN	Inch	Dash			
Q409HOF-041-08	Q409HOM-041-08	12.5	1/2"	-08	8	BSP FEMALE DIN3852-2 TYPE X	1/2" BSP

* Alternative termination ends can be provided - please ask your sales rep for details

Q.SAFE
480

Q410 SERIES

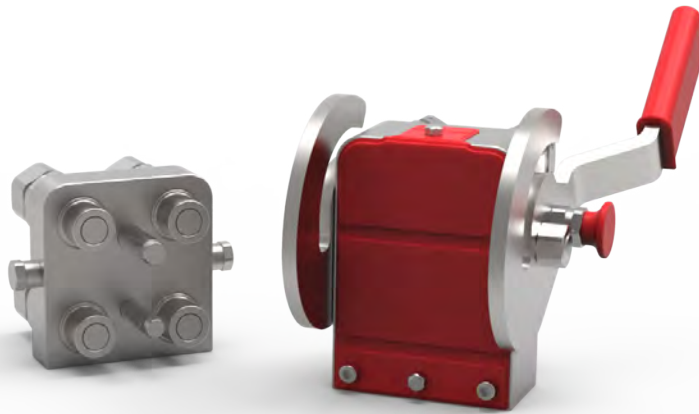

4 LINE MULTI-COUPLING
SINGLE-SIDED LEVER
LOCKING POSITION: LEFT *

* Right hand locking available on request
** Plate adaptor for frontal fixing available

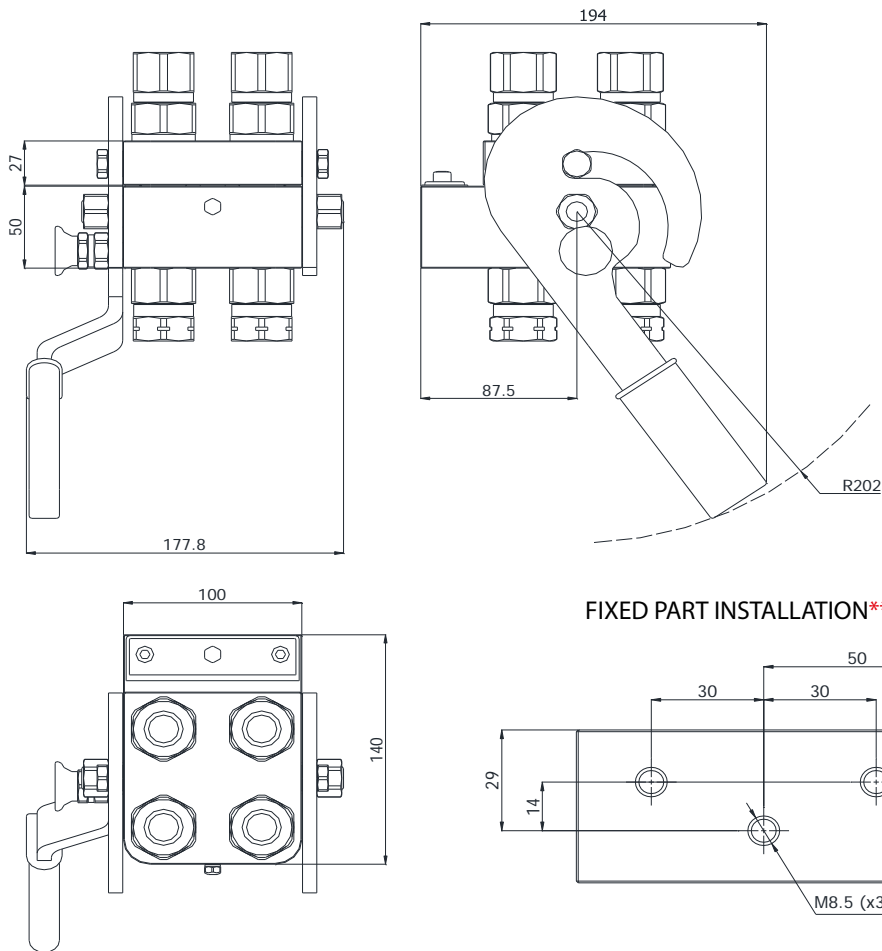

481 Q.SAFE

MULTI-COUPLING					TERMINATION END*		
PART NUMBER		SIZE			LINES	DESCRIPTION	THREAD
Fixed	Mobile	DN	Inch	Dash			
Q410D0F-041-08	Q410D0M-041-08	12.5	1/2"	-08	4	BSP FEMALE DIN3852-2 TYPE X	1/2" BSP
Q410C0F-041-08AA	Q410C0M-041-08AA	12.5	1/2"	-08	3	BSP FEMALE DIN3852-2 TYPE X	1/2" BSP

* Alternative termination ends can be provided - please ask your sales rep for details

Q411 SERIES

4 LINE MULTI-COUPLING
DOUBLE-SIDED LEVER
LOCKING POSITION: LEFT *

* Right hand locking available on request

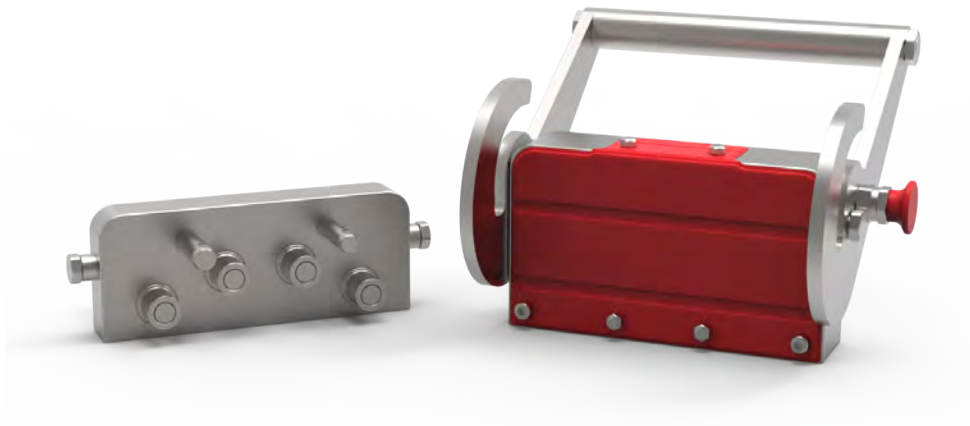

Q.SAFE
482

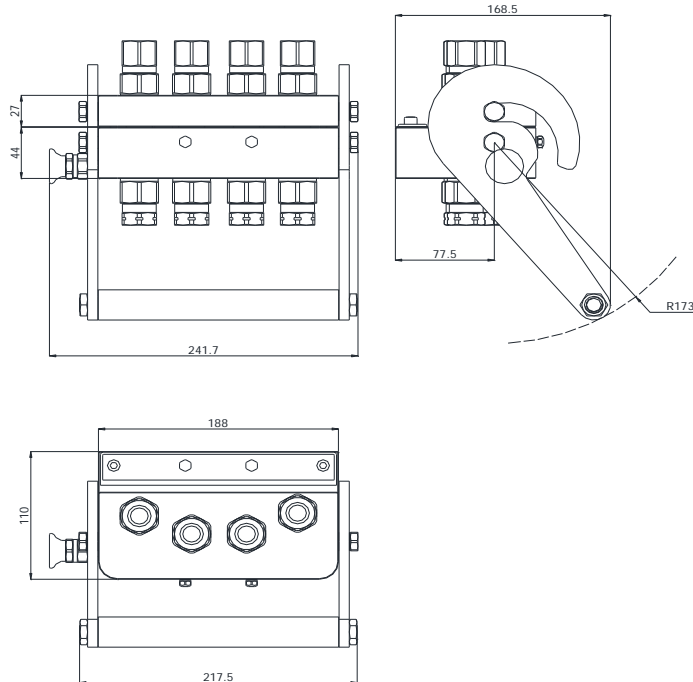

FIXED PART INSTALLATION**

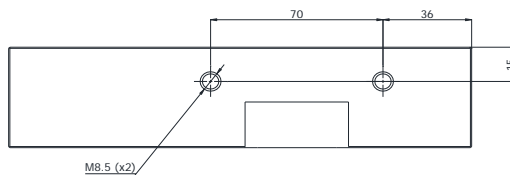

MULTI-COUPLING					TERMINATION END *		
PART NUMBER		SIZE			LINES	DESCRIPTION	THREAD
Fixed	Mobile	DN	Inch	Dash			
Q411D0F-041-06	Q411D0M-041-06	10	3/8"	-06	4	BSP FEMALE DIN3852-2 TYPE X	3/8" BSP

* Alternative termination ends can be provided - please ask your sales rep for details

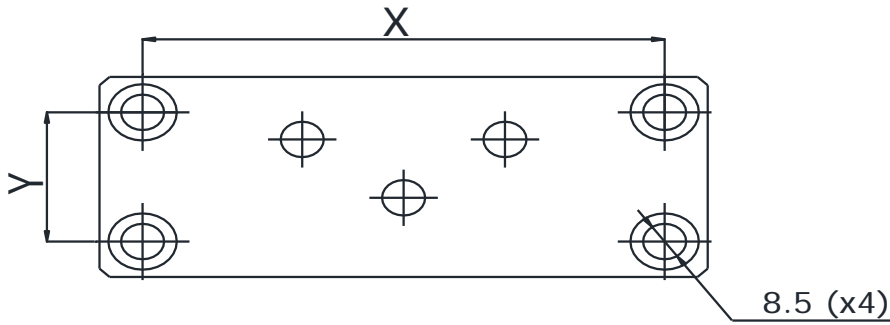

Q1AZ50BN

PLATE ADAPTOR FOR
MULTICONNECTOR

MULTICOUPLING SERIES	PART NUMBER	MATERIAL	DIMENSIONS mm	
			X	Y
Q401	Q1AZ50BN-01	ALUMINIUM	103	31
Q402	Q1AZ50BN-02	ALUMINIUM	103	31
Q403	Q1AZ50BN-03	ALUMINIUM	115	31
Q404	Q1AZ50BN-04	ALUMINIUM	115	31
Q406	Q1AZ50BN-06	ALUMINIUM	115	40
Q410	Q1AZ50BN-10	ALUMINIUM	115	31

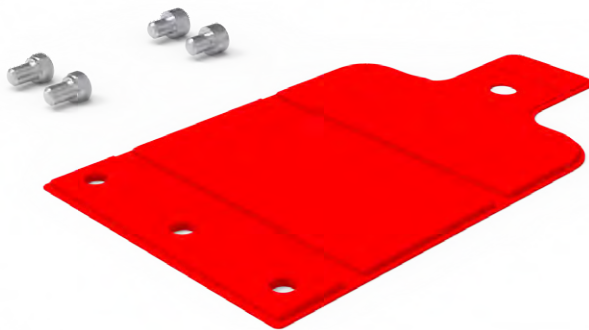

Q1AZ19FR

COVER FOR
MULTICONNECTOR

MULTICOUPLING SERIES	PART NUMBER	MATERIAL	COLOUR
Q401	Q1AZ19FR-01	STEEL+PU	RED
Q402	Q1AZ19FR-02	STEEL+PU	RED
Q403	Q1AZ19FR-03	STEEL+PU	RED
Q404	Q1AZ19FR-04	STEEL+PU	RED
Q405	Q1AZ19FR-05	STEEL+PU	RED
Q406	Q1AZ19FR-06	STEEL+PU	RED
Q407	Q1AZ19FR-07	STEEL+PU	RED
Q408	Q1AZ19FR-08	STEEL+PU	RED
Q409	Q1AZ19FR-09	STEEL+PU	RED
Q410	Q1AZ19FR-10	STEEL+PU	RED
Q411	Q1AZ19FR-11	STEEL+PU	RED

Q06811041A
Q06911041A

BSP TERMINATION ENDS
TO DIN 3852 X TYPE

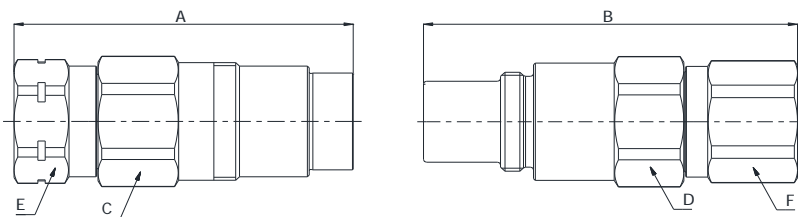

SIZE			PART NUMBER		THREAD	DIMENSIONS mm					
DN	Inch	Dash	Female coupling	Male coupling		A	B	C	D	E	F
10	3/8"	-06	Q06911041A-06-06	Q06811041A-06-06	3/8"	82.3	93.7	30	30	27	27
10	3/8"	-06	Q06911041A-06-08	Q06811041A-06-08	1/2"	85.3	96.5	30	30	27	27
12.5	1/2"	-08	Q06911041A-08-08	Q06811041A-08-08	1/2"	92.5	102	36	36	34	34
12.5	1/2"	-08	Q06911041A-08-12	Q06811041A-08-12	3/4"	94.5	105	36	36	34	34
20	3/4"	-12	Q06911041A-12-12	Q06811041A-12-12	3/4"	108	118.7	41	42	41	41
25	1"	-16	Q06911041A-16-16	Q06811041A-16-16	1"	119.4	126.3	50	50	50	50

Q.SAFE
484



Q1A0114

PARKING FOR MQS-A MALE
BULKHEAD MOUNTING

SIZE			PART NUMBER	MATERIAL	COLOUR
DN	Inch	Dash	Parking		
12.5	1/2"	-08	Q1A0114N-08	STEEL	-



Q1A0114-B

PARKING FOR MQS-A MALE

SIZE			PART NUMBER	MATERIAL	COLOUR
DN	Inch	Dash	Parking		
12.5	1/2"	-08	Q1A0114N-08B	STEEL	-



Q1A0104

PARKING FOR MQS-A MALE

SIZE			PART NUMBER	MATERIAL	COLOUR
DN	Inch	Dash	Parking		
12.5	1/2"	-08	Q1A0104N-08	STEEL	-



Q1A0114-T

PARKING WITH CAP FOR MQS-A MALE BULKHEAD MOUNTING

SIZE			PART NUMBER	MATERIAL	COLOUR
DN	Inch	Dash	Parking		
12.5	1/2"	-08	Q1A0114K-08T	STEEL + POM	BLACK

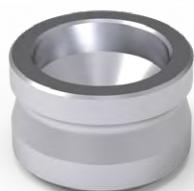

Q1AF104

PARKING FOR MQS-VB (BREAKING VALVES)

SIZE			PART NUMBER	MATERIAL	COLOUR
DN	Inch	Dash	Parking		
12.5	1/2"	-08	Q1AF104N-08	STEEL	-

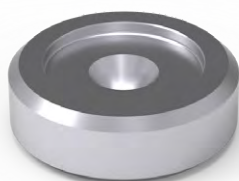

Q1AH104

PARKING FOR MQS-VS (AGRICULTURAL VALVES)

SIZE			PART NUMBER	MATERIAL	COLOUR
DN	Inch	Dash	Parking		
12.5	1/2"	-08	Q1AH104N-08	STEEL	-



Q1AP104

PARKING FOR MQS-ST
(SCREW TYPE MALE FOR TRUCK)

SIZE			PART NUMBER		MATERIAL	COLOUR
DN	Inch	Dash	Parking			
20	3/4"	-12	Q1AP104N-12		STEEL	-
25	1"	-16	Q1AP104N-16		STEEL	-



Q1A0B00 Q1A1B00

PLUGS AND CAPS
FOR MQS-A (ISO A)

SIZE			PART NUMBER		MATERIAL	COLOUR
DN	Inch	Dash	Plug for Female coupling	Cap for Male coupling		
6.3	1/4"	-04	Q1A1B00R-04	Q1A0B00R-04	PVC	RED
6.3	1/4"	-04	Q1A1B00Y-04	Q1A0B00Y-04	PVC	YELLOW
10	3/8"	-06	Q1A1B00R-06	Q1A0B00R-06	PVC	RED
10	3/8"	-06	Q1A1B00Y-06	Q1A0B00Y-06	PVC	YELLOW
10	3/8"	-06	Q1A1B00K-06	Q1A0B00K-06	PVC	BLACK
12.5	1/2"	-08	Q1A1B00R-08	Q1A0B00R-08	PVC	RED
12.5	1/2"	-08	Q1A1B00B-08	Q1A0B00B-08	PVC	BLUE
12.5	1/2"	-08	Q1A1B00G-08	Q1A0B00G-08	PVC	GREEN
12.5	1/2"	-08	Q1A1B00Y-08	Q1A0B00Y-08	PVC	YELLOW
12.5	1/2"	-08	Q1A1B00K-08	Q1A0B00K-08	PVC	BLACK
12.5	1/2"	-08	Q1A1B00H-08	Q1A0B00H-08	PVC	WHITE
20	3/4"	-12	Q1A1B00R-12	Q1A0B00R-12	PVC	RED
20	3/4"	-12	Q1A1B00Y-12	Q1A0B00Y-12	PVC	YELLOW
25	1"	-16	Q1A1B00R-16	Q1A0B00R-16	PVC	RED
25	1"	-16	Q1A1B00Y-16	Q1A0B00Y-16	PVC	YELLOW



Q1A0B00 Q1A1B00

PLUGS AND CAPS
FOR MQS-AP (ISO A
CONNECTABLE UNDER
PRESSURE)

SIZE			PART NUMBER		MATERIAL	COLOUR
DN	Inch	Dash	Plug for Female coupling	Cap for Male coupling		
12.5	1/2"	-08	Q1A1B00R-08	Q1A0B00R-08	PVC	RED
12.5	1/2"	-08	Q1A1B00B-08	Q1A0B00B-08	PVC	BLUE
12.5	1/2"	-08	Q1A1B00G-08	Q1A0B00G-08	PVC	GREEN
12.5	1/2"	-08	Q1A1B00Y-08	Q1A0B00Y-08	PVC	YELLOW
12.5	1/2"	-08	Q1A1B00K-08	Q1A0B00K-08	PVC	BLACK
12.5	1/2"	-08	Q1A1B00H-08	Q1A0B00H-08	PVC	WHITE

Q.SAFE 488



Q1A1B00

PLUGS FOR MQS-AF
(ISO A PUSH-PULL)

SIZE			PART NUMBER		MATERIAL	COLOUR
DN	Inch	Dash	Plug for Female coupling	Cap for Male coupling		
6.3	1/4"	-04	Q1A1B00R-04	-	PVC	RED
6.3	1/4"	-04	Q1A1B00Y-04	-	PVC	YELLOW
10	3/8"	-06	Q1A1B00R-06	-	PVC	RED
10	3/8"	-06	Q1A1B00Y-06	-	PVC	YELLOW
10	3/8"	-06	Q1A1B00K-06	-	PVC	BLACK
12.5	1/2"	-08	Q1A1B00R-08	-	PVC	RED
12.5	1/2"	-08	Q1A1B00B-08	-	PVC	BLUE
12.5	1/2"	-08	Q1A1B00G-08	-	PVC	GREEN
12.5	1/2"	-08	Q1A1B00Y-08	-	PVC	YELLOW
12.5	1/2"	-08	Q1A1B00K-08	-	PVC	BLACK
12.5	1/2"	-08	Q1A1B00H-08	-	PVC	WHITE
20	3/4"	-12	Q1A1B00R-12	-	PVC	RED
20	3/4"	-12	Q1A1B00Y-12	-	PVC	YELLOW
25	1"	-16	Q1A1B00R-16	-	PVC	RED
25	1"	-16	Q1A1B00Y-16	-	PVC	YELLOW



Q1A1B00

PLUGS FOR MQS-AM & MQS-AB (ISO A), MQS-AFP, MQS-AFM, MQS-AFB, MQS-ARM & MQS-ARB (ISO A PUSH-PULL)

SIZE			PART NUMBER		MATERIAL	COLOUR
DN	Inch	Dash	Plug for Female coupling	Cap for Male coupling		
12.5	1/2"	-08	Q1A1B00R-08	-	PVC	RED
12.5	1/2"	-08	Q1A1B00B-08	-	PVC	BLUE
12.5	1/2"	-08	Q1A1B00G-08	-	PVC	GREEN
12.5	1/2"	-08	Q1A1B00Y-08	-	PVC	YELLOW
12.5	1/2"	-08	Q1A1B00K-08	-	PVC	BLACK
12.5	1/2"	-08	Q1A1B00H-08	-	PVC	WHITE



Q1A5B00 Q1A4B00

PLUGS AND CAPS FOR MQS-N (STANDARD) SERIES

SIZE			PART NUMBER		MATERIAL	COLOUR
DN	Inch	Dash	Plug for Female coupling	Cap for Male coupling		
6.3	1/4"	-04	Q1A5B00R-04	Q1A4B00R-04	PVC	RED
6.3	1/4"	-04	Q1A5B00B-04	Q1A4B00B-04	PVC	BLUE
6.3	1/4"	-04	Q1A5B00G-04	Q1A4B00G-04	PVC	GREEN
10	3/8"	-06	Q1A5B00R-06	Q1A4B00R-06	PVC	RED
10	3/8"	-06	Q1A5B00B-06	Q1A4B00B-06	PVC	BLUE
12.5	1/2"	-08	SEE PLUGS AND CAPS FOR ISO SERIES A			
20	3/4"	-12	Q1A5B00R-12	Q1A4B00R-12	PVC	RED
20	3/4"	-12	Q1A5B00B-12	Q1A4B00B-12	PVC	BLUE
20	3/4"	-12	Q1A5B00Y-12	Q1A4B00Y-12	PVC	YELLOW



Q1A9B00 Q1A8B00

PLUGS AND CAPS FOR
MQS-F (FLAT-FACE) &
MQS-FH (FLAT-FACE HIGH
PRESSURE)

SIZE			PART NUMBER		MATERIAL	COLOUR
DN	Inch	Dash	Cap for female coupling	Cap for male coupling		
6.3	1/4"	-04	Q1A9B00R-04	Q1A8B00R-04	PVC	RED
6.3	1/4"	-04	Q1A9B00B-04	Q1A8B00B-04	PVC	BLUE
10	3/8"	-06	Q1A9B00R-06	Q1A8B00R-06	PVC	RED
10	3/8"	-06	Q1A9B00B-06	Q1A8B00B-06	PVC	BLUE
12.5	1/2"	-08	Q1A9B00R-08	Q1A8B00R-08	PVC	RED
12.5	1/2"	-08	Q1A9B00B-08	Q1A8B00B-08	PVC	BLUE
16	5/8"	-10	Q1A9B00R-10	Q1A8B00R-10	PVC	RED
20	3/4"	-12	Q1A9B00R-12	Q1A8B00R-12	PVC	RED
20	3/4"	-12	Q1A9B00B-12	Q1A8B00B-12	PVC	BLUE
25	1"	-16	Q1A9B00R-16	Q1A8B00R-16	PVC	RED
25	1"	-16	Q1A9B00B-16	Q1A8B00B-16	PVC	BLUE

Q.SAFE 490



Q1A8B00

CAPS FOR
MQS-FP (FLAT-FACE MALE
CONNECTABLE UNDER
PRESSURE)

SIZE			PART NUMBER		MATERIAL	COLOUR
DN	Inch	Dash	Plug for Female coupling	Cap for Male coupling		
10	3/8"	-06	-	Q1A8B00R-06	PVC	RED
10	3/8"	-06	-	Q1A8B00B-06	PVC	BLUE
12.5	1/2"	-08	-	Q1A8B00R-08	PVC	RED
12.5	1/2"	-08	-	Q1A8B00B-08	PVC	BLUE
16	5/8"	-10	-	Q1A8B00R-10	PVC	RED
19	3/4"	-12	-	Q1A8B00R-12	PVC	RED
19	3/4"	-12	-	Q1A8B00B-12	PVC	BLUE
25	1"	-16	-	Q1A8B00R-16	PVC	RED
25	1"	-16	-	Q1A8B00B-16	PVC	BLUE



Q1A3B00
Q1A2B00

PLUGS AND CAPS
FOR MQS-B (ISO B)

SIZE			PART NUMBER		MATERIAL	COLOUR
DN	Inch	Dash	Plug for Female coupling	Cap for Male coupling		
6.3	1/4"	-04	Q1A3B00R-04	Q1A2B00R-04	PVC	RED



Q1AJA00
Q1AIA00

PLUGS AND CAPS
FOR MQS-SGR (SCREW-TYPE)
& MQS-SG (SCREW-TYPE)

SIZE			PART NUMBER		MATERIAL	COLOUR
DN	Inch	Dash	Cap for female coupling	Plug for male coupling		
6.3	1/4"	-04	Q1AJA00R-04	Q1AIA00R-04	PE-HD	RED
10	3/8"	-06	Q1AJA00R-06	Q1AIA00R-06	PE-HD	RED
12.5	1/2"	-08	Q1AJA00R-08	Q1AIA00R-08	PE-HD	RED
20	3/4"	-12	Q1AJA00R-12	Q1AIA00R-12	PE-HD	RED
25	1"	-16	Q1AJA00R-16	Q1AIA00R-16	PE-HD	RED
38	1.1/2"	-24	Q1AJA00R-24	Q1AIA00R-24	PE-HD	RED



Q1AJ100 Q1AI100

CAPS AND PLUGS
FOR MQS-SG (SCREW-TYPE)
& MQS-SGR (SCREW-TYPE
GERMAN MARKET)

SIZE			PART NUMBER		MATERIAL	COLOUR
DN	Inch	Dash	Cap for female coupling	Plug for male coupling		
6.3	1/4"	-04	Q1AJ100N-04	Q1AI100N-04	STEEL + PE-LD	-
10	3/8"	-06	Q1AJ100N-06	Q1AI100N-06	STEEL + PE-LD	-
12.5	1/2"	-08	Q1AJ100N-08	Q1AI100N-08	STEEL + PE-LD	-
20	3/4"	-12	Q1AJ100N-12	Q1AI100N-12	STEEL + PE-LD	-
25	1"	-16	Q1AJ100N-16	Q1AI100N-16	STEEL + PE-LD	-

Q.SAFE 492



Q1AN100 Q1AM100

CAPS AND PLUGS
FOR MQS-SC (SCREW-TYPE
HYDRAULIC CYLINDERS)

SIZE			PART NUMBER		MATERIAL	COLOUR
DN	Inch	Dash	Plug for Female coupling	Cap for Male coupling		
6.3	1/4"	-04	Q1AN100N-04	Q1AM100N-04	STEEL + PE-LD	-
10	3/8"	-06	Q1AN100N-06	Q1AM100N-06	STEEL + PE-LD	-



Q1AQ100 Q1AP100

CAPS AND PLUGS
FOR MQS-ST
(SCREW-TYPE TRUCKS)

SIZE			PART NUMBER		MATERIAL	COLOUR
DN	Inch	Dash	Cap for female coupling	Plug for male coupling		
20	3/4"	-12	Q1AQ100N-12	Q1AP100N-12	STEEL	-
25	1"	-16	Q1AQ100N-16	Q1AP100N-16	STEEL	-



Q1AL100 Q1AK100

CAPS AND PLUGS
FOR MQS-SH (SCREW-TYPE
FOR VERY HIGH PRESSURE)

SIZE			PART NUMBER		MATERIAL	COLOUR
DN	Inch	Dash	Plug for Female coupling	Cap for Male coupling		
6.3	1/4"	-04	Q1AL100N-04	Q1AK100N-04	STEEL + PE-LD	-
10	3/8"	-06	Q1AL100N-06	Q1AK100N-06	STEEL + PE-LD	-
12.5	1/2"	-08	Q1AL100N-08	Q1AK100N-08	STEEL + PE-LD	-
20	3/4"	-12	Q1AL100N-12	Q1AK100N-12	STEEL + PE-LD	-
25	1"	-16	Q1AL100N-16	Q1AK100N-16	STEEL + PE-LD	-



Q1ACB00

CAP
FOR MQS-D (DIAGNOSTIC)

SIZE			PART NUMBER	MATERIAL	COLOUR
DN	Inch	Dash	Cap for Male coupling		
5	1/8"	-02	Q1ACB00K-02	PVC	BLACK



Q1AEA00

CAP
FOR MQS-VB
(BRAKING VALVES)

SIZE			PART NUMBER	MATERIAL	COLOUR
DN	Inch	Dash	Cap for Male coupling		
12.5	1/2"	-08	Q1AEA00R-08	PVC	RED



Q1AGA00

CAP
FOR MQS-VS
(AGRICULTURAL VALVES)

SIZE			PART NUMBER	MATERIAL	COLOUR
DN	Inch	Dash	Cap for Male coupling		
12.5	1/2"	-08	Q1AGA00R-08	PE-HD	RED



Q1A1D02

AUTOMATIC CAP
FOR MQS-AF (PUSH-PULL)

SIZE			PART NUMBER	MATERIAL	COLOUR
DN	Inch	Dash	Cap for Female coupling		
12.5	1/2"	-08	Q1A1D02Y-08	POM	YELLOW
12.5	1/2"	-08	Q1A1D02R-08	POM	RED
12.5	1/2"	-08	Q1A1D02K-08	POM	BLACK
12.5	1/2"	-08	Q1A1D02G-08	POM	GREEN
12.5	1/2"	-08	Q1A1D02B-08	POM	BLUE
20	3/4"	-12	Q1A1D02Y-12	POM	YELLOW
20	3/4"	-12	Q1A1D02R-12	POM	RED
20	3/4"	-12	Q1A1D02K-12	POM	BLACK
20	3/4"	-12	Q1A1D02G-12	POM	GREEN
20	3/4"	-12	Q1A1D02B-12	POM	BLUE



Q1A1D02

AUTOMATIC CAP
FOR MQS-AFP, MQS-AFM,
MQS-AFB, MQS-ARM &
MQS-ARB (ISO A PUSH-PULL)

SIZE			PART NUMBER		MATERIAL	COLOUR
DN	Inch	Dash	Cap for Female coupling			
12.5	1/2"	-08	Q1A1D02B-08		POM	BLUE
12.5	1/2"	-08	Q1A1D02G-08		POM	GREEN
12.5	1/2"	-08	Q1A1D02K-08		POM	BLACK
12.5	1/2"	-08	Q1A1D02R-08		POM	RED
12.5	1/2"	-08	Q1A1D02Y-08		POM	YELLOW



Q1A9D02

AUTOMATIC CAP
FOR MQS-F (FEMALE)
& MQS-FH (FEMALE)

SIZE			PART NUMBER		MATERIAL	COLOUR
DN	Inch	Dash	Plug for Female coupling			
12.5	1/2"	-08	Q1A9D02R-08		POM	RED
16	5/8"	-10	Q1A9D02B-10		POM	BLUE
20	3/4"	-12	Q1A9D02B-12		POM	BLUE



Q1AL500 Q1AK500

CAPS AND PLUGS
FOR MQS-SH (SCREW-TYPE
VERY HIGH PRESSURE)

SIZE			PART NUMBER		MATERIAL	COLOUR
DN	Inch	Dash	Plug for Female coupling	Cap for Male coupling		
31.5	1.1/4"	-20	Q1AL500N-20	Q1AK500N-20	ALUMINIUM + STEEL	-
38	1.1/2"	-24	Q1AL500N-24	Q1AK500N-24	ALUMINIUM + STEEL	-



Q1AW500 Q1AV500

CAPS AND PLUGS
FOR MQS-FS (SCREW-TYPE
FLAT FACE)

SIZE			PART NUMBER		MATERIAL	COLOUR
DN	Inch	Dash	Plug for Female coupling	Cap for Male coupling		
10	3/8"	-06	Q1AW500N-06	Q1AV500N-06	ALUMINIUM + STEEL	-
12.5	1/2"	-08	Q1AW500N-08	Q1AV500N-08	ALUMINIUM + STEEL	-
16	5/8"	-10	Q1AW500N-10	Q1AV500N-10	ALUMINIUM + STEEL	-
19	3/4"	-12	Q1AW500N-12	Q1AV500N-12	ALUMINIUM + STEEL	-
25	1"	-16	Q1AW500N-16	Q1AV500N-16	ALUMINIUM + STEEL	-
38	1-1/2"	-24	Q1AW500N-24	Q1AV500N-24	ALUMINIUM + STEEL	-

Q.SAFE 496

Q1A8093



SHAPED SEAL FOR MQS-F
(FLAT-FACE), MQS-FH (FLAT-
FACE HIGH PRESSURE) &
MQS-FP (FLAT-FACE MALE
CONNECTABLE UNDER
PRESSURE)

SIZE			PART NUMBER	KIT	MATERIAL
DN	Inch	Dash			
6.3	1/4"	-04	Q1A8093N-04	SHAPED SEAL	POLYURETHANE
10	3/8"	-06	Q1A8093N-06	SHAPED SEAL	POLYURETHANE
12.5	1/2"	-08	Q1A8093N-08	SHAPED SEAL	POLYURETHANE
16	5/8"	-10	Q1A8093N-10	SHAPED SEAL	POLYURETHANE
20	3/4"	-12	Q1A8093N-12	SHAPED SEAL	POLYURETHANE
25	1"	-16	Q1A8093N-16	SHAPED SEAL	POLYURETHANE

Q1AV093



SHAPED SEAL FOR MQS-FS
(FLAT-FACE SCREW TYPE)

SIZE			PART NUMBER	KIT	MATERIAL
DN	Inch	Dash			
10	3/8"	-06	Q1AV093N-06	SHAPED SEAL	POLYURETHANE
12.5	1/2"	-08	Q1AV093N-08	SHAPED SEAL	POLYURETHANE
16	5/8"	-10	Q1AV093N-10	SHAPED SEAL	POLYURETHANE
20	3/4"	-12	Q1AV093N-12	SHAPED SEAL	POLYURETHANE
25	1"	-16	Q1AV093N-16	SHAPED SEAL	POLYURETHANE
38	1.1/2"	-24	Q1AV093N-24	SHAPED SEAL	POLYURETHANE



Q1A1013

O-RING AND BACK-UP RING
FOR MQS-A (ISO A)

SIZE			PART NUMBER	KIT	MATERIAL	
DN	Inch	Dash			O-Ring	Backup Ring
6.3	1/4"	-04	Q1A1013N-04	O-RING + BACK-UP RING	NBR	PTFE
10	3/8"	-06	Q1A1013N-06	O-RING + BACK-UP RING	NBR	PTFE
12.5	1/2"	-08	Q1A1013N-08	O-RING + BACK-UP RING	NBR	PTFE
20	3/4"	-12	Q1A1013N-12	O-RING + BACK-UP RING	NBR	PTFE
25	1"	-16	Q1A1013N-16	O-RING + BACK-UP RING	NBR	PTFE
31.5	1.1/4"	-20	Q1A1013N-20	O-RING + BACK-UP RING	NBR	PTFE
40	1.1/2"	-24	Q1A1013N-24	O-RING + BACK-UP RING	NBR	PTFE
51	2"	-32	Q1A1013N-32	O-RING + BACK-UP RING	NBR	PTFE



Q1A1013

O-RING AND BACK-UP RING
FOR MQS-AF
(ISO A PUSH-PULL)

SIZE			PART NUMBER	KIT	MATERIAL	
DN	Inch	Dash			O-Ring	Backup Ring
6.3	1/4"	-04	Q1A1013N-04	O-RING + BACK-UP RING	NBR	PTFE
10	3/8"	-06	Q1A1013N-06	O-RING + BACK-UP RING	NBR	PTFE
12.5	1/2"	-08	Q1A1013N-08	O-RING + BACK-UP RING	NBR	PTFE
20	3/4"	-12	Q1A1013N-12	O-RING + BACK-UP RING	NBR	PTFE
25	1"	-16	Q1A1013N-16	O-RING + BACK-UP RING	NBR	PTFE

Q.SAFE 498



Q1A1013

O-RING AND BACK-UP RING
FOR MQS-AP, MQS-AM &
MQS-AB (ISO A), MQS-AFP,
MQS-AFM, MQS-AFB, MQS-
ARM & MQS-ARB
(ISO A PUSH-PULL)

SIZE			PART NUMBER	KIT	MATERIAL	
DN	Inch	Dash			O-Ring	Backup Ring
12.5	1/2"	-08	Q1A1013N-08	O-RING + BACK-UP RING	NBR	PTFE



Q1A3013

O-RING AND BACK-UP RING
FOR MQS-B (ISO B)

SIZE			PART NUMBER	KIT	MATERIAL	
DN	Inch	Dash			O-Ring	Backup Ring
5	1/8"	-02	Q1A3013N-02	O-RING + BACK-UP RING	NBR	PTFE
6.3	1/4"	-04	Q1A3013N-04	O-RING + BACK-UP RING	NBR	PTFE
10	3/8"	-06	Q1A3013N-06	O-RING + BACK-UP RING	NBR	PTFE
12.5	1/2"	-08	Q1A3013N-08	O-RING + BACK-UP RING	NBR	PTFE
20	3/4"	-12	Q1A3013N-12	O-RING + BACK-UP RING	NBR	PTFE
25	1"	-16	Q1A3013N-16	O-RING + BACK-UP RING	NBR	PTFE



Q1A5013

O-RING AND BACK-UP RING
FOR MQS-N
(STANDARD SERIES)

SIZE			PART NUMBER	KIT	MATERIAL	
DN	Inch	Dash			O-Ring	Backup Ring
6.3	1/4"	-04	Q1A5013N-04	O-RING + BACK-UP RING	NBR	PTFE
10	3/8"	-06	Q1A5013N-06	O-RING + BACK-UP RING	NBR	PTFE
12.5	1/2"	-08	SEE SPARE PARTS FOR ISO SERIES			
20	3/4"	-12	Q1A5013N-12	O-RING + BACK-UP RING	NBR	PTFE
20	3/4"	-12	Q1A5013N-12B	O-RING + BACK-UP RING	NBR	PTFE
25	1"	-16	Q1A5013N-16	O-RING + BACK-UP RING	NBR	PTFE
25	1"	-16	Q1A5013N-16B	O-RING + BACK-UP RING	NBR	PTFE
25	1"	-16	Q1A5013N-16C	O-RING + BACK-UP RING	NBR	PTFE
31.5	1.1/4"	-20	Q1A5013N-20	O-RING + BACK-UP RING	NBR	PTFE
40	1.1/2"	-24	Q1A5013N-24	O-RING + BACK-UP RING	NBR	PTFE



Q1AJ013

O-RING AND BACK-UP RING
FOR MQS-SG
& MQS-SGR (SCREW-TYPE)

SIZE			PART NUMBER	KIT	MATERIAL	
DN	Inch	Dash			O-Ring	Backup Ring
6.3	1/4"	-04	Q1AJ013N-04	O-RING + BACK-UP RING	NBR	PTFE
10	3/8"	-06	Q1AJ013N-06	O-RING + BACK-UP RING	NBR	PTFE
12.5	1/2"	-08	Q1AJ013N-08	O-RING + BACK-UP RING	NBR	PTFE
20	3/4"	-12	Q1AJ013N-12	O-RING + BACK-UP RING	NBR	PTFE
25	1"	-16	Q1AJ013N-16	O-RING + BACK-UP RING	NBR	PTFE
40	1.1/2"	-24	Q1AJ013N-24	O-RING + BACK-UP RING	NBR	PTFE

Q.SAFE 500



Q1AN013

O-RING AND BACK-UP RING
FOR MQS-SC (SCREW-TYPE
HYDRAULIC CYLINDERS)

SIZE			PART NUMBER	KIT	MATERIAL	
DN	Inch	Dash			O-Ring	Backup Ring
6.3	1/4"	-04	Q1AN013N-04	O-RING + BACK-UP RING	NBR	PTFE
10	3/8"	-06	Q1AN013N-06	O-RING + BACK-UP RING	NBR	PTFE



Q1AQ013

O-RING RING
FOR MQS-ST (SCREW-TYPE
FOR TRUCKS)

SIZE			PART NUMBER	KIT	MATERIAL	
DN	Inch	Dash			O-Ring	Backup Ring
20	3/4"	-12	Q1AQ013N-12	O-RING	NBR	-
25	1"	-16	Q1AQ013N-16	O-RING	NBR	-



Q1AL013

O-RING AND BACK-UP RING
FOR MQS-SH (SCREW-TYPE
FOR VERY HIGH PRESSURE)

SIZE			PART NUMBER	KIT	MATERIAL	
DN	Inch	Dash			O-Ring	Backup Ring
6.3	1/4"	-04	Q1AL013N-04	O-RING + BACK-UP RING	NBR	PTFE
10	3/8"	-06	Q1AL013N-06	O-RING + BACK-UP RING	NBR	PTFE
12.5	1/2"	-08	Q1AL013N-08	O-RING + BACK-UP RING	NBR	PTFE
20	3/4"	-12	Q1AL013N-12	O-RING + BACK-UP RING	NBR	PTFE
25	1"	-16	Q1AL013N-16	O-RING + BACK-UP RING	NBR	PTFE
31.5	1¼"	-20	Q1AL013N-20	O-RING + BACK-UP RING	NBR	PTFE
38	1½"	-24	Q1AL013N-24	O-RING + BACK-UP RING	NBR	PTFE

ABOUT Q.SAFE CHECK VALVES

Manuli Hydraulics’ check valves are expertly designed for optimal hydrodynamic performance, ensuring minimal pressure drop across the component, and therefore minimising the impact on the fluid flow in your systems. Manufactured from high quality steel with a Cr3+ (trivalent chrome) plating, Manuli check valves offer superior corrosion resistance - up to 500 hours to red rust in salt spray conditions - with the option to upgrade to our new E-Coat 1000 plating (1,000 hours to red rust) on request.

Valve sealing is supplied by a C98 high-carbon steel spring and (where required) a nitrile (NBR) o-ring and back-up ring arrangement, which prevents unwanted creeping of the rubber seal over time.

Manuli check valve housings come in 3 basic forms, “Standard”, “DHI” and “Compact”. This choice of housing design makes it even easier for you to include Manuli check valves into your systems regardless of space constraints.

The Manuli check valve range also includes “Bi-Directional” options for both the “Standard” and “DHI” housing types, to allow an even greater level of pressure control in your systems.

Q.SAFE CHECK VALVES

ACCESSORY TYPE	SIZE								PAGE No.
	1/4"	3/8"	1/2"	3/4"	1"	1 1/4"	1 1/2"	2"	
STANDARD	Green	Green	Green	Green	Green	Green	Green	Green	504
COMPACT	Green	Green	Green	Green	Green	White	White	White	511
BI-DIRECTIONAL	White	Green	Green	Green	White	White	White	White	515
STANDARD - DHI	Green	Green	Green	Green	Green	Green	Green	Green	518
BI-DIRECTIONAL - DHI	White	Green	Green	Green	White	White	White	White	522

Q.SAFE
502

How to order Manuli Check Valves

Our portfolio of check valves is designed to allow maximum flexibility of selection with the minimum number of unique parts required. So for all of our off-the-shelf valve families it is possible to have any of the listed configurations supplied with any one of the standard crack pressures.

When placing your order simply substitute the 11th character in the part number for the relevant "Digit" shown in the table below.

Note: All part numbers in the following pages are shown with a "A" in this position, corresponding to a 35 kPa (5.1 psi) crack pressure.*

** Except in the case of bi-directional check valves where all the options are listed.*



CRACK PRESSURE OPTIONS

Digit	Pressure (kPa)	Pressure (psi)
A	35	5.1
B	10	1.5
C	20	2.9
D	50	7.3
E	100	14.5
F	150	21.8
G	200	29.0
H	250	36.3
J	300	43.5
K	350	50.8
L	400	58.0
M	450	65.3
N	500	72.5
P	600	87.0
Q	700	101.5
R	800	116.0
S	900	130.5
T	1000	145.0
X	Without Spring	

Example:

Part number "Q2A1110505A-04-04" would specify a 35 kPa crack pressure.

Part number "Q2A1110505M-04-04" would specify exactly the same valve configuration, but with a 450 kPa crack pressure.

Note: When specifying the crack pressure for a bi-directional check valve the digit value would refer to the crack pressure in the B-A direction. A-B direction crack pressure is always 35 kPa.

STANDARD CHECK VALVES



Pressure Drop

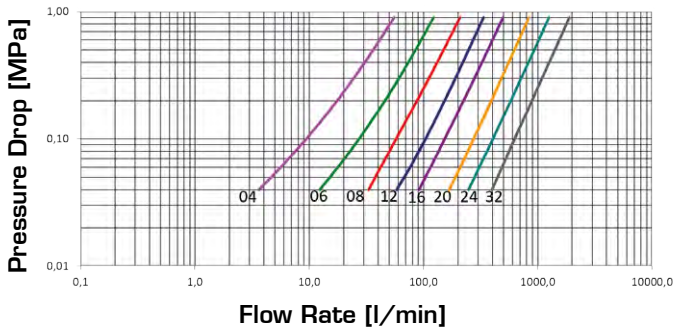

Pressure Drop

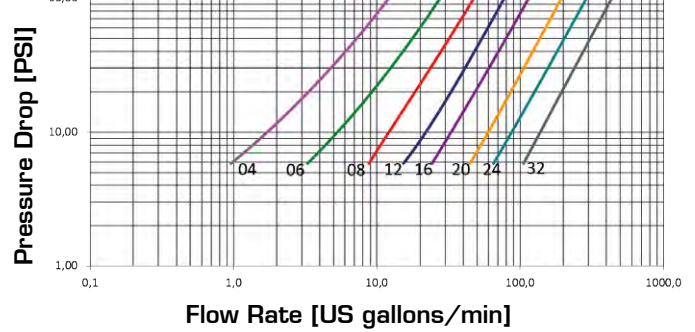

Q.SAFE 504

TECHNICAL DATA

SIZE			WORKING PRESSURE (Dynamic)		RATED FLOW at 0.2 MPa of pressure drop		MINIMUM BURST PRESSURE	
DN	inch	Dash	MPa	PSI	l/min	US GPM	MPa	PSI
6	1/4"	04	45	6,525	18	4.8	180	26,100
10	3/8"	06	35	5,075	46	12.2	140	20,300
12	1/2"	08	35	5,075	88	23.2	140	20,300
19	3/4"	12	35	5,075	153	40.4	140	20,300
25	1"	16	35	5,075	225	59.4	140	20,300
31	1.1/4"	20	35	5,075	394	104.1	140	20,300
38	1.1/2"	24	35	5,075	580	153.2	140	20,300
51	2"	32	35	5,075	890	235.1	140	20,300

PRODUCT DESCRIPTION

- Manufactured from high-quality materials
- Robust design
- Large range of termination end options available
- Large range of cracking-pressure available

MATERIAL

Steel, with springs in C98 high-carbon steel. Seals in NBR and back-up ring in PTFE.

WORKING TEMPERATURE

-22°F up to +230°F (-30°C up to +110°C)

SAFETY FACTOR

4:1 for dynamic pressures

IMPULSE PRESSURES

1,000,000 cycles at 120% of the rated one (freq. 1Hz)

TEST SPECIFICATIONS

ISO 18869

Q2A1110505

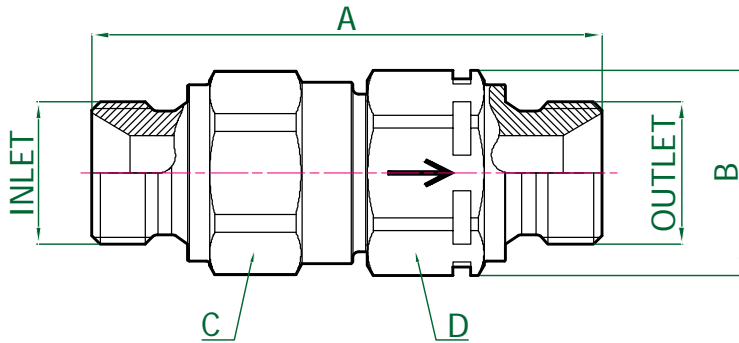

MALE-MALE, STANDARD
INLET: BSP MALE 60° CONE SEAT
 BS5200 / ISO 8434-6
OUTLET: BSP MALE 60° CONE SEAT
 BS5200 / ISO 8434-6
MATERIAL: STEEL
SEALS: NBR (NITRILE)

NOMINAL SIZE			PART NUMBER	OPENING PRESSURE	THREADS		DIMENSIONS mm				
DN	inch	Dash			INLET	OUTLET	A	B	C	D	E
6	1/4"	-04	Q2A1110505A-04-04	35 kPa	1/4"	1/4"	56	Ø21	19	19	
10	3/8"	-06	Q2A1110505A-06-06	35 kPa	3/8"	3/8"	64	Ø24,2	22	22	
12.5	1/2"	-08	Q2A1110505A-08-08	35 kPa	1/2"	1/2"	74.5	Ø30	27	27	
19	3/4"	-12	Q2A1110505A-12-12	35 kPa	3/4"	3/4"	88.2	Ø38	34	34	
25	1"	-16	Q2A1110505A-16-16	35 kPa	1"	1"	100.9	Ø45	41	41	
31	1-1/4"	-20	Q2A1110505A-20-20	35 kPa	1-1/4"	1-1/4"	122.4	Ø55	50	50	
38	1-1/2"	-24	Q2A1110505A-24-24	35 kPa	1-1/2"	1-1/2"	141	Ø66	60	60	
51	2"	-32	Q2A1110505A-32-32	35 kPa	2"	2"	173.7	Ø82	75	75	

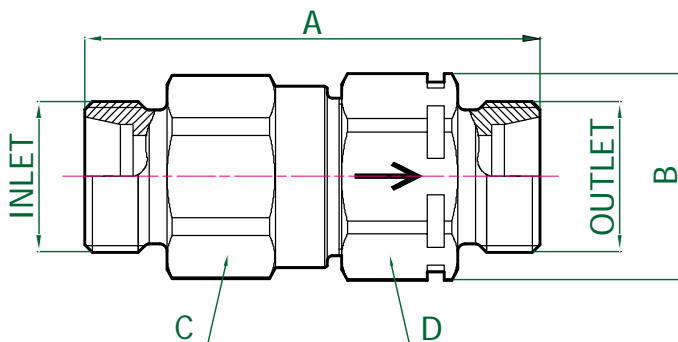

Q2A1111111

MALE-MALE, STANDARD
INLET: METRIC MALE 24° CONE SEAT
 LIGHT TYPE DIN 3861 / ISO 8434-1
OUTLET: METRIC MALE 24° CONE SEAT
 LIGHT TYPE DIN 3861 / ISO 8434-1
MATERIAL: STEEL
SEALS: NBR (NITRILE)

NOMINAL SIZE			PART NUMBER	OPENING PRESSURE	THREADS		DIMENSIONS mm				
DN	inch	Dash			INLET	OUTLET	A	B	C	D	E
6	1/4"	-04	Q2A1111111A-12-12	35 kPa	M12X1,5	M12X1,5	50.5	Ø21	19	19	
6	1/4"	-04	Q2A1111111A-14-14	36 kPa	M14X1,5	M14X1,5	50.5	Ø21	19	19	
10	3/8"	-06	Q2A1111111A-18-18	35 kPa	M18X1,5	M18X1,5	58.5	Ø24,2	22	22	
12.5	1/2"	-08	Q2A1111111A-22-22	35 kPa	M22X1,5	M22X1,5	66.5	Ø30	27	27	
19	3/4"	-12	Q2A1111111A-26-26	35 kPa	M26X1,5	M26X1,5	74.5	Ø38	34	34	
25	1"	-16	Q2A1111111A-30-30	35 kPa	M30X2	M30X2	84.5	Ø45	41	41	
31	1-1/4"	-20	Q2A1111111A-36-36	35 kPa	M36X2	M36X2	104	Ø55	50	50	

Q.SAFE
505

Q2A111212

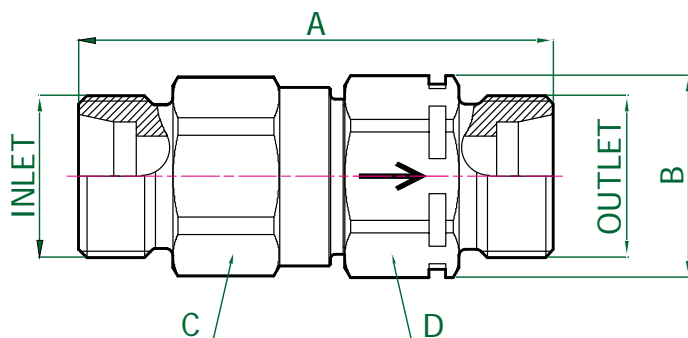

MALE-MALE, STANDARD
INLET: METRIC MALE 24° CONE SEAT
 HEAVY TYPE DIN 3861 / ISO 8434-1
OUTLET: METRIC MALE 24° CONE SEAT
 HEAVY TYPE DIN 3861 / ISO 8434-1
MATERIAL: STEEL
SEALS: NBR (NITRILE)

NOMINAL SIZE			PART NUMBER	OPENING PRESSURE	THREADS		DIMENSIONS mm				
DN	inch	Dash			INLET	OUTLET	A	B	C	D	E
6	1/4"	-04	Q2A1111212A-16-16	35 kPa	M16X1,5	M16X1,5	54.5	Ø21	19	19	
10	3/8"	-06	Q2A1111212A-20-20	35 kPa	M20X1,5	M20X1,5	60.5	Ø24,2	22	22	
12.5	1/2"	-08	Q2A1111212A-24-24	35 kPa	M24X1,5	M24X1,5	70.5	Ø30	27	27	
19	3/4"	-12	Q2A1111212A-30-30	35 kPa	M30X2	M30X2	82.5	Ø38	34	34	
25	1"	-16	Q2A1111212A-36-36	35 kPa	M36X2	M36X2	92.5	Ø45	41	41	

Q.SAFE 506

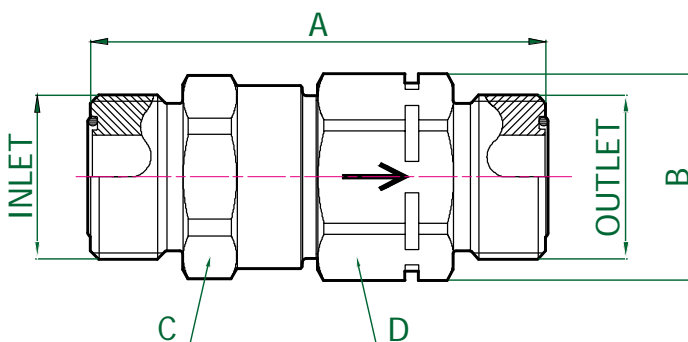

Q2A1112424

MALE-MALE, STANDARD
INLET: ORFS MALE ISO 8434-3
 / SAE J1453
OUTLET: ORFS MALE ISO 8434-3
 / SAE J1453
MATERIAL: STEEL
SEALS: NBR (NITRILE)

NOMINAL SIZE			PART NUMBER	OPENING PRESSURE	THREADS		DIMENSIONS mm				
DN	inch	Dash			INLET	OUTLET	A	B	C	D	E
10	3/8"	-06	Q2A1112424A-06-06	35 kPa	11/16"-16 UN	11/16"-16 UN	58.9	Ø24,2	22	22	
12.5	1/2"	-08	Q2A1112424A-08-08	35 kPa	13/16"-16 UN	13/16"-16 UN	68.1	Ø30	27	27	
20	3/4"	-12	Q2A1112424A-10-10	35 kPa	1"-14 UNS	1"-14 UNS	74.3	Ø38	34	34	
20	3/4"	-12	Q2A1112424A-12-12	35 kPa	1.3/16"-12 UN	1.3/16"-12 UN	83.8	Ø38	34	34	
25	1"	-16	Q2A1112424A-16-16	35 kPa	1.7/16"-12 UN	1.7/16"-12 UN	91.5	Ø45	41	41	

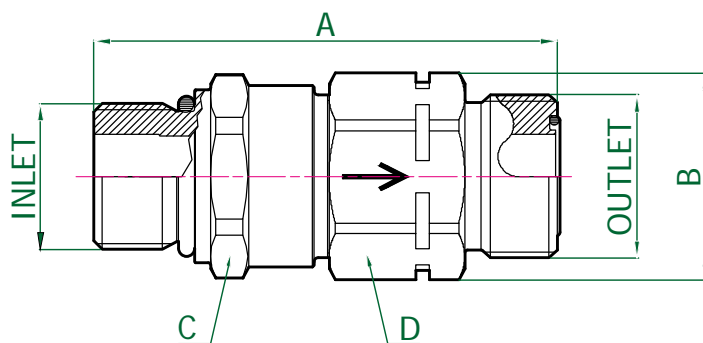

Q2A1113224

MALE-MALE, STANDARD
INLET: MALE O'RING BOSS
 (NON-ADJUSTABLE HEAVY) SAE J1926-2
OUTLET: ORFS MALE ISO 8434-3
 / SAE J1453
MATERIAL: STEEL
SEALS: NBR (NITRILE)

NOMINAL SIZE			PART NUMBER	OPENING PRESSURE	THREADS		DIMENSIONS mm				
DN	inch	Dash			INLET	OUTLET	A	B	C	D	E
10	3/8"	-06	Q2A1113224A-06-06	35 kPa	9/16"-18 UNF	11/16"-16 UN	59.7	Ø24,2	22	22	
12.5	1/2"	-08	Q2A1113224A-08-08	35 kPa	3/4"-16 UNF	13/16"-16 UN	69.3	Ø30	27	27	
20	3/4"	-12	Q2A1113224A-10-10	35 kPa	7/8"-14 UNF	1"-14 UNS	80.5	Ø38	34	34	
20	3/4"	-12	Q2A1113224A-12-12	35 kPa	1.1/16"-12 UN	1.3/16"-12 UN	86	Ø38	34	34	
25	1"	-16	Q2A1113224A-16-16	35 kPa	1.5/16"-12 UN	1.7/16"-12 UN	92.5	Ø45	41	41	

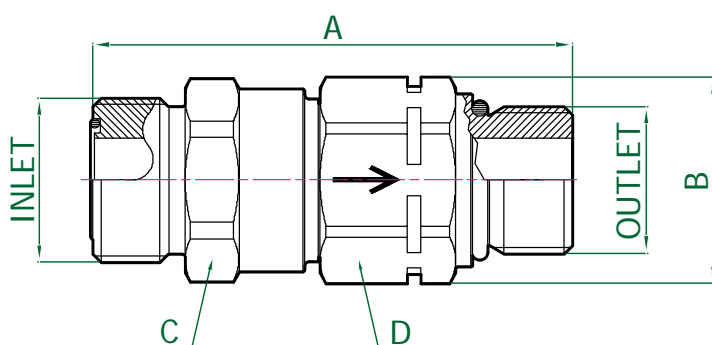

Q2A1112432

MALE-MALE, STANDARD
INLET: ORFS MALE ISO 8434-3
 / SAE J1453
OUTLET: MALE O'RING BOSS
 (NON-ADJUSTABLE HEAVY) SAE J1926-2
MATERIAL: STEEL
SEALS: NBR (NITRILE)

NOMINAL SIZE			PART NUMBER	OPENING PRESSURE	THREADS		DIMENSIONS mm				
DN	inch	Dash			INLET	OUTLET	A	B	C	D	E
10	3/8"	-06	Q2A1112432A-06-06	35 kPa	11/16"-16 UN	9/16"-18 UNF	60.7	Ø24,2	22	22	
12.5	1/2"	-08	Q2A1112432A-08-08	35 kPa	13/16"-16 UN	3/4"-16 UNF	72	Ø30	27	27	
20	3/4"	-12	Q2A1112432A-10-10	35 kPa	1"-14 UNS	7/8"-14 UNF	81.3	Ø38	34	34	
20	3/4"	-12	Q2A1112432A-12-12	35 kPa	1.3/16"-12 UN	1.1/16"-12 UN	85.3	Ø38	34	34	
25	1"	-16	Q2A1112432A-16-16	35 kPa	1.7/16"-12 UN	1.5/16"-12 UN	92.5	Ø45	41	41	

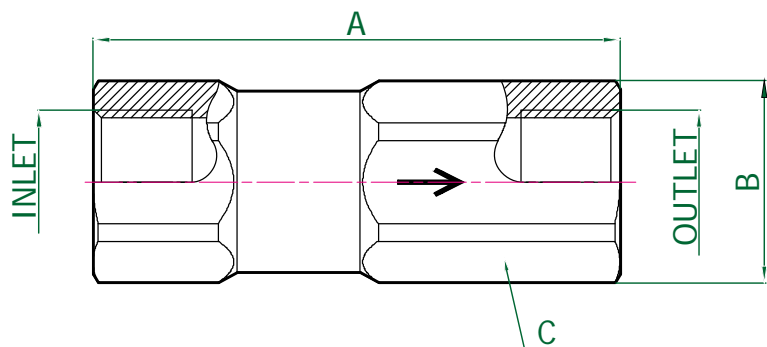

Q2A2100404

FEMALE-FEMALE, STANDARD
INLET: BSP FIXED FEMALE
 DIN 3852-2 'FORM X' / ISO 1179-1
OUTLET: BSP FIXED FEMALE
 DIN 3852-2 'FORM X' / ISO 1179-1
MATERIAL: STEEL
SEALS: NBR (NITRILE)

NOMINAL SIZE			PART NUMBER	OPENING PRESSURE	THREADS		DIMENSIONS mm				
DN	inch	Dash			INLET	OUTLET	A	B	C	D	E
6	1/4"	-04	Q2A2100404A-04-04	35 kPa	1/4"	1/4"	60	Ø21	19		
10	3/8"	-06	Q2A2100404A-06-06	35 kPa	3/8"	3/8"	65 (67*)	Ø24.2	22		
12.5	1/2"	-08	Q2A2100404A-08-08	35 kPa	1/2"	1/2"	77 (81*)	Ø29.6	27		
19	3/4"	-12	Q2A2100404A-12-12	35 kPa	3/4"	3/4"	90	Ø37.4	34		
25	1"	-16	Q2A2100404A-16-16	35 kPa	1"	1"	104	Ø45	41		
31	1-1/4"	-20	Q2A2100404A-20-20	35 kPa	1-1/4"	1-1/4"	128.5	Ø55	50		
38	1-1/2"	-24	Q2A2100404A-24-24	35 kPa	1-1/2"	1-1/2"	148	Ø66	60		
51	2"	-32	Q2A2100404A-32-32	35 kPa	2"	2"	178	Ø82	75		

Q.SAFE 508

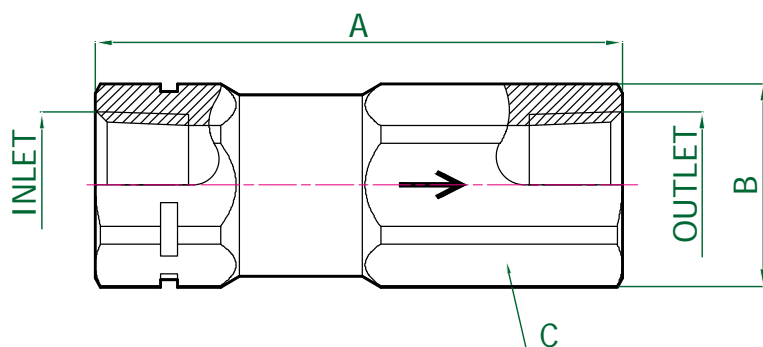

Q2A2103434

FEMALE-FEMALE, STANDARD
INLET: NPTF FIXED FEMALE
 SAE J476A
OUTLET: NPTF FIXED FEMALE
 SAE J476A
MATERIAL: STEEL
SEALS: NBR (NITRILE)

NOMINAL SIZE			PART NUMBER	OPENING PRESSURE	THREADS		DIMENSIONS mm				
DN	inch	Dash			INLET	OUTLET	A	B	C	D	E
6	1/4"	-04	Q2A2103434A-04-04	35 kPa	1/4" NPTF	1/4" NPTF	60	Ø21	19		
10	3/8"	-06	Q2A2103434A-06-06	35 kPa	3/8" NPTF	3/8" NPTF	65 (67*)	Ø24.2	22		
12.5	1/2"	-08	Q2A2103434A-08-08	35 kPa	1/2" NPTF	1/2" NPTF	77 (81*)	Ø29.6	27		
19	3/4"	-12	Q2A2103434A-12-12	35 kPa	3/4" NPTF	3/4" NPTF	90	Ø37.4	34		
25	1"	-16	Q2A2103434A-16-16	35 kPa	1" NPTF	1" NPTF	104	Ø45	41		
31	1-1/4"	-20	Q2A2103434A-20-20	35 kPa	1-1/4" NPTF	1-1/4" NPTF	128.5	Ø55	50		
38	1-1/2"	-24	Q2A2103434A-24-24	35 kPa	1-1/2" NPTF	1-1/2" NPTF	148	Ø66	60		
51	2"	-32	Q2A2103434A-32-32	35 kPa	2" NPTF	2" NPTF	178	Ø82	75		

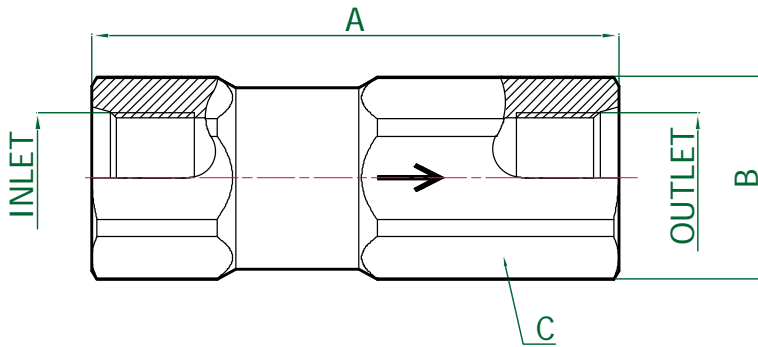

Q2A2103030

FEMALE-FEMALE, STANDARD
INLET: FEMALE O’RING BOSS TYPE
 SAE J1926-1
OUTLET: FEMALE O’RING BOSS TYPE
 SAE J1926-1
MATERIAL: STEEL
SEALS: NBR (NITRILE)

NOMINAL SIZE			PART NUMBER	OPENING PRESSURE	THREADS		DIMENSIONS mm				
DN	inch	Dash			INLET	OUTLET	A	B	C	D	E
12.5	1/2"	-08	Q2A2103030A-08-08	35 kPa	3/4"-16 UNF	3/4"-16 UNF	77 (81*)	Ø29.6	27		
19	3/4"	-12	Q2A2103030A-12-12	35 kPa	1.1/16"-12 UN	1.1/16"-12 UN	96	Ø37.4	34		
25	1"	-16	Q2A2103030A-16-16	35 kPa	1.5/16"-12 UN	1.5/16"-12 UN	104	Ø45	41		

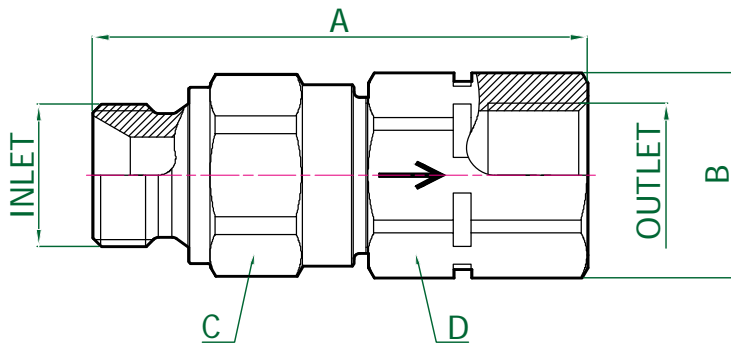

Q2A3110504

MALE-FEMALE, STANDARD
INLET: BSP MALE 60° CONE SEAT
 BS5200 / ISO 8434-6
OUTLET: BSP FIXED FEMALE
 DIN 3852-2 'FORM X' / ISO 1179-1
MATERIAL: STEEL
SEALS: NBR (NITRILE)

NOMINAL SIZE			PART NUMBER	OPENING PRESSURE	THREADS		DIMENSIONS mm				
DN	inch	Dash			INLET	OUTLET	A	B	C	D	E
6	1/4"	-04	Q2A3110504A-04-04	35 kPa	1/4"	1/4"	54.8	Ø21	19	19	
10	3/8"	-06	Q2A3110504A-06-06	35 kPa	3/8"	3/8"	63.8	Ø24,2	22	22	
12.5	1/2"	-08	Q2A3110504A-08-08	35 kPa	1/2"	1/2"	72.3	Ø30	27	27	
19	3/4"	-12	Q2A3110504A-12-12	35 kPa	3/4"	3/4"	83	Ø38	34	34	
25	1"	-16	Q2A3110504A-16-16	35 kPa	1"	1"	95.7	Ø45	41	41	

Q2A4110405

FEMALE-MALE, STANDARD

INLET: BSP FIXED FEMALE

DIN 3852-2 'FORM X' / ISO 1179-1

OUTLET: BSP MALE 60° CONE SEAT

BS5200 / ISO 8434-6

MATERIAL: STEEL

SEALS: NBR (NITRILE)

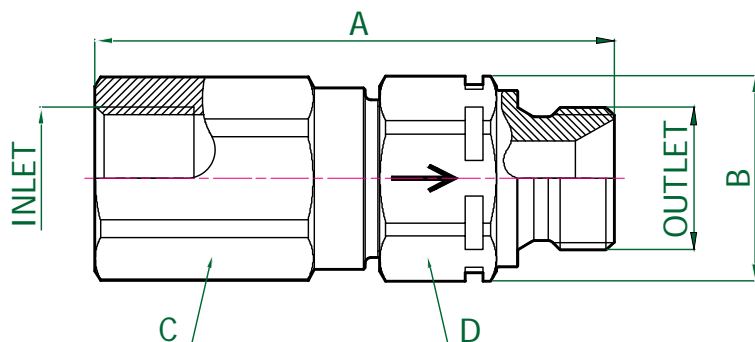

NOMINAL SIZE			PART NUMBER	OPENING PRESSURE	THREADS		DIMENSIONS mm				
DN	inch	Dash			INLET	OUTLET	A	B	C	D	E
6	1/4"	-04	Q2A4110405A-04-04	35 kPa	1/4"	1/4"	62.5	Ø21	19	19	
10	3/8"	-06	Q2A4110405A-06-06	35 kPa	3/8"	3/8"	70.5	Ø24,2	22	22	
12.5	1/2"	-08	Q2A4110405A-08-08	35 kPa	1/2"	1/2"	83	Ø30	27	27	
19	3/4"	-12	Q2A4110405A-12-12	35 kPa	3/4"	3/4"	96.5	Ø38	34	34	
25	1"	-16	Q2A4110405A-16-16	35 kPa	1"	1"	111.5	Ø45	41	41	

COMPACT CHECK VALVES



Pressure Drop

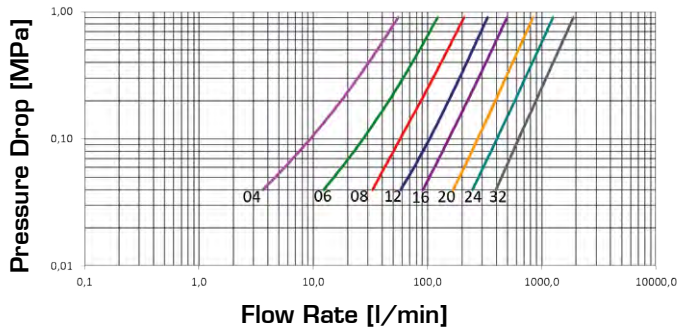

Pressure Drop

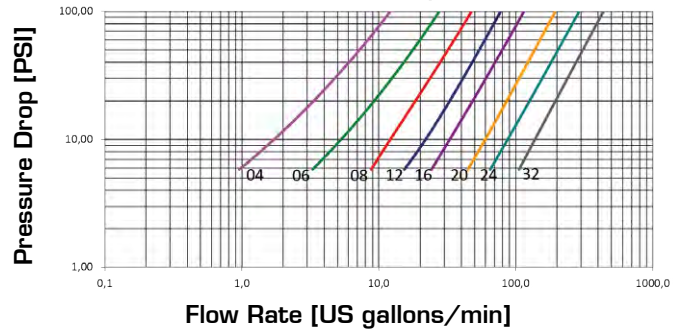

TECHNICAL DATA

SIZE			MPa		FLOW RATE		MINIMUM BURST PRESSURE	
WORKING PRESSURE (Dynamic)			RATED FLOW at 0.2 MPa of pressure drop		MINIMUM BURST PRESSURE			
DN	inch	Dash	MPa	PSI	l/min	US GPM	MPa	PSI
6	1/4"	04	35	5,075	5	1.3	140	20,300
10	3/8"	06	35	5,075	11	2.9	140	20,300
12	1/2"	08	35	5,075	37	9.8	140	20,300
19	3/4"	12	35	5,075	73	19.3	140	20,300
25	1"	16	35	5,075	106	28.0	140	20,300

PRODUCT DESCRIPTION

- Manufactured from high-quality materials
- Robust design
- Space saving design
- Large range of termination end options available
- Large range of cracking-pressure available

MATERIAL

Steel, with springs in C98 high-carbon steel. Seals in NBR and back-up ring in PTFE.

WORKING TEMPERATURE

-22°F up to +230°F (-30°C up to +110°C)

SAFETY FACTOR

4:1 for dynamic pressures

IMPULSE PRESSURES

1,000,000 cycles at 120% of the rated one (freq. 1Hz)

TEST SPECIFICATIONS

ISO 18869

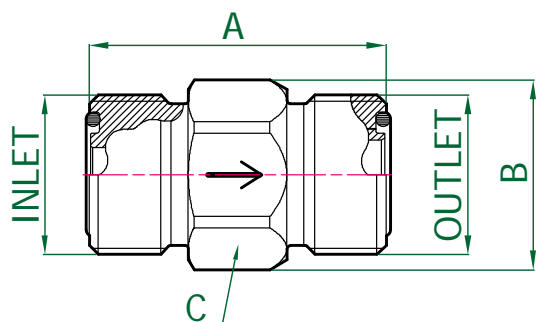

Q2B1112424

MALE-MALE, COMPACT
INLET: ORFS MALE ISO 8434-3
 / SAE J1453
OUTLET: ORFS MALE ISO 8434-3
 / SAE J1453
MATERIAL: STEEL
SEALS: NBR (NITRILE)

NOMINAL SIZE			PART NUMBER	OPENING PRESSURE	THREADS		DIMENSIONS mm				
DN	inch	Dash			INLET	OUTLET	A	B	C	D	E
6	1/4"	-4	Q2B1112424A-04-04	35 kPa	9/16"-18 UNF	9/16"-18 UNF	31	ø18,8	17		
10	3/8"	-6	Q2B1112424A-06-06	35 kPa	11/16"-16 UN	11/16"-16 UN	33.6	ø21	19		
12.5	1/2"	-8	Q2B1112424A-08-08	35 kPa	13/16"-16 UN	13/16"-16 UN	38.3	ø24,5	22		
12.5	1/2"	-8	Q2B1112424A-10-10	35 kPa	1"-14 UNS	1"-14 UNS	43.7	ø30	27		
20	3/4"	-12	Q2B1112424A-12-12	35 kPa	1.3/16"-12 UN	1.3/16"-12 UN	46.7	ø35,5	32		
25	1"	-16	Q2B1112424A-16-16	35 kPa	1.7/16"-12 UN	1.7/16"-12 UN	50.8	ø42	38		

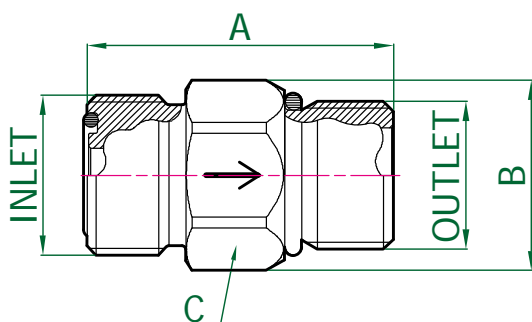

Q2B1112432

MALE-MALE, COMPACT
INLET: ORFS MALE ISO 8434-3
 / SAE J1453
OUTLET: MALE O'RING BOSS
 (NON-ADJUSTABLE HEAVY) SAE J1926-2
MATERIAL: STEEL
SEALS: NBR (NITRILE)

NOMINAL SIZE			PART NUMBER	OPENING PRESSURE	THREADS		DIMENSIONS mm				
DN	inch	Dash			INLET	OUTLET	A	B	C	D	E
10	3/8"	-6	Q2B1112432A-06-06	35 kPa	11/16"-16 UN	9/16"-18 UNF	34.4	ø21	19		
12.5	1/2"	-8	Q2B1112432A-08-08	35 kPa	13/16"-16 UN	3/4"-16 UNF	39.5	ø24,5	22		
12.5	1/2"	-8	Q2B1112432A-10-10	35 kPa	1"-14 UNS	7/8"-14 UNF	44.2	ø30	27		
20	3/4"	-12	Q2B1112432A-12-12	35 kPa	1.3/16"-12 UN	1.1/16"-12 UN	48.2	ø35,5	32		
25	1"	-16	Q2B1112432A-16-16	35 kPa	1.7/16"-12 UN	1.5/16"-12 UN	51.8	ø42	38		

Q2B1112525

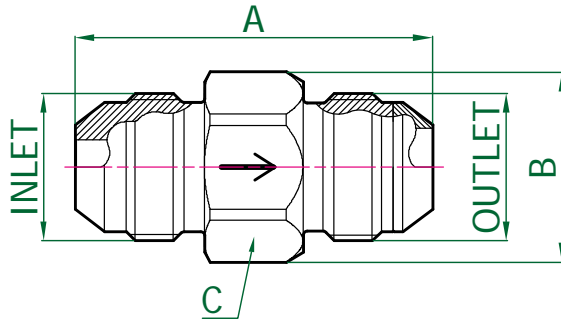

MALE-MALE, COMPACT
INLET: JIC MALE (37° CONE)
ISO 8434-2 / SAE J514
OUTLET: JIC MALE (37° CONE)
ISO 8434-2 / SAE J514
MATERIAL: STEEL
SEALS: NBR (NITRILE)

NOMINAL SIZE			PART NUMBER	OPENING PRESSURE	THREADS		DIMENSIONS mm				
DN	inch	Dash			INLET	OUTLET	A	B	C	D	E
6	1/4"	-4	Q2B1112525A-04-04	35 kPa	7/16"-20 UNF	7/16"-20 UNF	39.2	ø18,8	17		
10	3/8"	-6	Q2B1112525A-06-06	35 kPa	9/16"-18 UNF	9/16"-18 UNF	39.4	ø21	19		
12.5	1/2"	-8	Q2B1112525A-08-08	35 kPa	3/4"-16 UNF	3/4"-16 UNF	46.1	ø24,5	22		
12.5	1/2"	-8	Q2B1112525A-10-10	35 kPa	7/8"-14 UNF	7/8"-14 UNF	51.3	ø30	27		
20	3/4"	-12	Q2B1112525A-12-12	35 kPa	1.1/16"-12 UN	1.1/16"-12 UN	56.5	ø35,5	32		
25	1"	-16	Q2B1112525A-16-16	35 kPa	1.5/16"-12 UN	1.5/16"-12 UN	62	ø42	38		

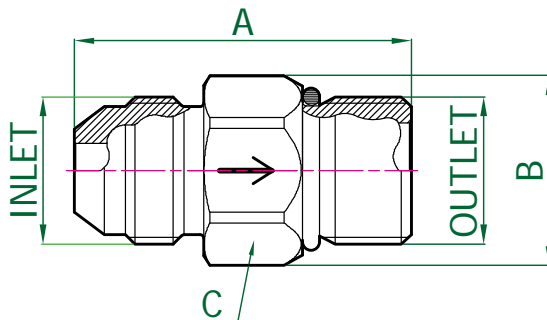

Q2B1112532

MALE-MALE, COMPACT
INLET: JIC MALE (37° CONE)
ISO 8434-2 / SAE J514
OUTLET: MALE O'RING BOSS
(NON-ADJUSTABLE HEAVY) SAE J1926-2
MATERIAL: STEEL
SEALS: NBR (NITRILE)

NOMINAL SIZE			PART NUMBER	OPENING PRESSURE	THREADS		DIMENSIONS mm				
DN	inch	Dash			INLET	OUTLET	A	B	C	D	E
10	3/8"	-6	Q2B1112532A-06-06	35 kPa	9/16"-18 UNF	9/16"-18 UNF	37.3	ø21	19		
12.5	1/2"	-8	Q2B1112532A-08-08	35 kPa	3/4"-16 UNF	3/4"-16 UNF	43.4	ø24,5	22		
12.5	1/2"	-8	Q2B1112532A-10-10	35 kPa	7/8"-14 UNF	7/8"-14 UNF	48	ø30	27		
20	3/4"	-12	Q2B1112532A-12-12	35 kPa	1.1/16"-12 UN	1.1/16"-12 UN	53.1	ø35,5	32		
25	1"	-16	Q2B1112532A-16-16	35 kPa	1.5/16"-12 UN	1.5/16"-12 UN	57.4	ø42	38		

Q2B1113224

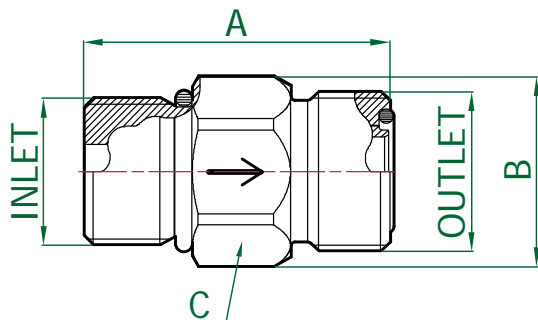

MALE-MALE, COMPACT
INLET: MALE O'RING BOSS
 (NON-ADJUSTABLE HEAVY) SAE J1926-2
OUTLET: ORFS MALE ISO 8434-3
 / SAE J1453
MATERIAL: STEEL
SEALS: NBR (NITRILE)

NOMINAL SIZE			PART NUMBER	OPENING PRESSURE	THREADS		DIMENSIONS mm				
DN	inch	Dash			INLET	OUTLET	A	B	C	D	E
6	1/4"	-4	Q2B1113224A-04-04	35 kPa	7/16"-20 UNF	9/16"-18 UNF	32.2	ø18,8	17		
10	3/8"	-6	Q2B1113224A-06-06	35 kPa	9/16"-18 UNF	11/16"-16 UN	34.4	ø21	19		
12.5	1/2"	-8	Q2B1113224A-08-08	35 kPa	3/4"-16 UNF	13/16"-16 UN	39.5	ø24,5	22		
12.5	1/2"	-8	Q2B1113224A-10-10	35 kPa	7/8"-14 UNF	1"-14 UNS	44.2	ø30	27		
20	3/4"	-12	Q2B1113224A-12-12	35 kPa	1.1/16"-12 UN	1.3/16"-12 UN	48.2	ø35,5	32		
25	1"	-16	Q2B1113224A-16-16	35 kPa	1.5/16"-12 UN	1.7/16"-12 UN	51.8	ø42	38		

Q.SAFE 514

Q2B1113225

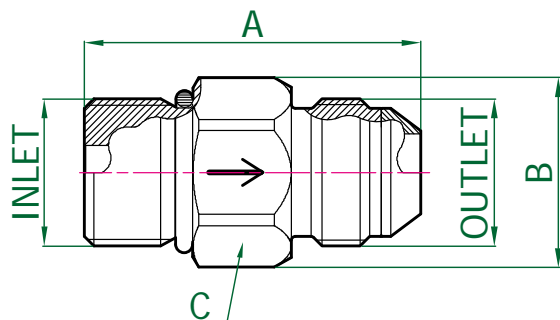

MALE-MALE, COMPACT
INLET: MALE O'RING BOSS
 (NON-ADJUSTABLE HEAVY) SAE J1926-2
OUTLET: JIC MALE (37° CONE)
 ISO 8434-2 / SAE J514
MATERIAL: STEEL
SEALS: NBR (NITRILE)

NOMINAL SIZE			PART NUMBER	OPENING PRESSURE	THREADS		DIMENSIONS mm				
DN	inch	Dash			INLET	OUTLET	A	B	C	D	E
6	1/4"	-4	Q2B1113225A-04-04	35 kPa	7/16"-20 UNF	7/16"-20 UNF	36.2	ø18,8	17		
10	3/8"	-6	Q2B1113225A-06-06	35 kPa	9/16"-18 UNF	9/16"-18 UNF	37.3	ø21	19		
12.5	1/2"	-8	Q2B1113225A-08-08	35 kPa	3/4"-16 UNF	3/4"-16 UNF	43.4	ø24,5	22		
12.5	1/2"	-8	Q2B1113225A-10-10	35 kPa	7/8"-14 UNF	7/8"-14 UNF	48	ø30	27		
20	3/4"	-12	Q2B1113225A-12-12	35 kPa	1.1/16"-12 UN	1.1/16"-12 UN	53.1	ø35,5	32		
25	1"	-16	Q2B1113225A-16-16	35 kPa	1.5/16"-12 UN	1.5/16"-12 UN	57.4	ø42	38		



BI-DIRECTIONAL CHECK VALVES

TECHNICAL DATA

SIZE			WORKING PRESSURE (Dynamic)		RATED FLOW at 0.2 MPa of pressure drop		MINIMUM BURST PRESSURE	
DN	inch	Dash	MPa	PSI	l/min	US GPM	MPa	PSI
10	3/8"	06	35	5075	39	10	150	21750
12.5	1/2"	08	35	5075	84	22	140	20300
19	3/4"	-12	35	5075	119	31	140	20300

PRODUCT DESCRIPTION

- Manufactured from high-quality materials
- Robust design
- Large range of termination end options available
- A-B cracking pressures of 500kPa and 800kPa available
- B-A cracking pressure of 35kPa

MATERIAL

Steel, with springs in C98 high-carbon steel. Seals in NBR and back-up ring in PTFE.

WORKING TEMPERATURE

-22°F up to +230°F (-30°C up to +110°C)

SAFETY FACTOR

4:1 for dynamic pressures

IMPULSE PRESSURES

1,000,000 cycles at 120% of the rated one (freq. 1Hz)

TEST SPECIFICATIONS

ISO 18869

How Do Manuli Bi-Directional Check Valves Work?

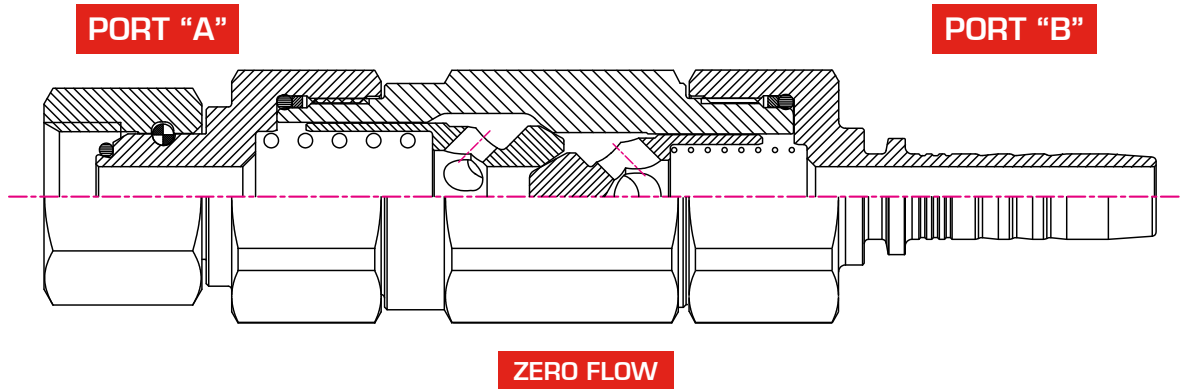

In its zero flow state the bi-directional check valve is sealed in both flow directions, meaning that no fluid can cross from port "A" to port "B" or vice versa.

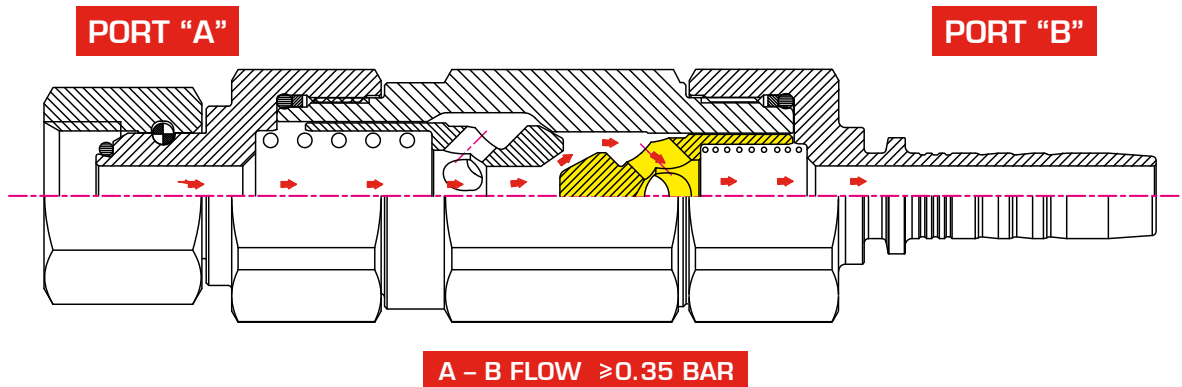

When the pressure of the fluid flowing from port "A" to port "B" exceeds the specified valve rating, "X" kPa, the highlighted valve assembly is similarly forced out of the way to allow the fluid to flow.

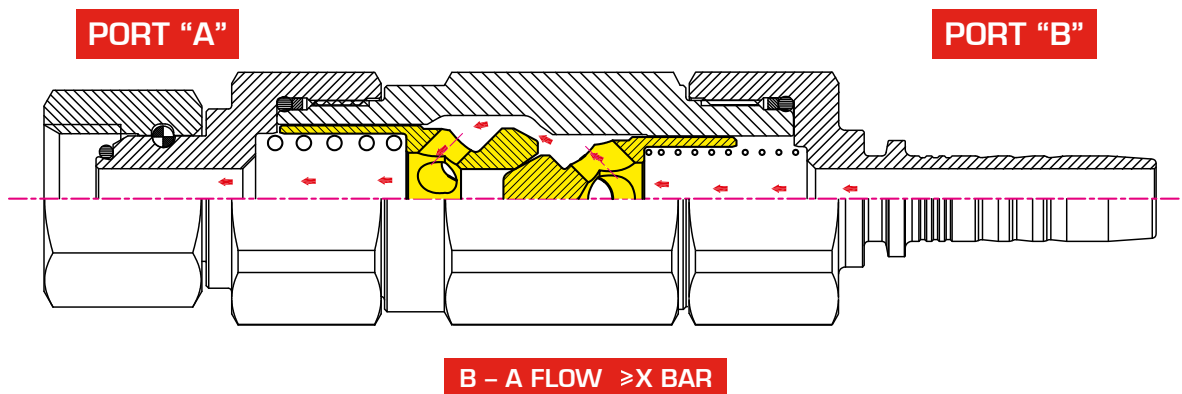

When the pressure of the fluid flowing from port "B" to port "A" exceeds 35 kPa the highlighted valve assembly is forced out of the way, thus allowing the fluid to flow.

Q2D1110505

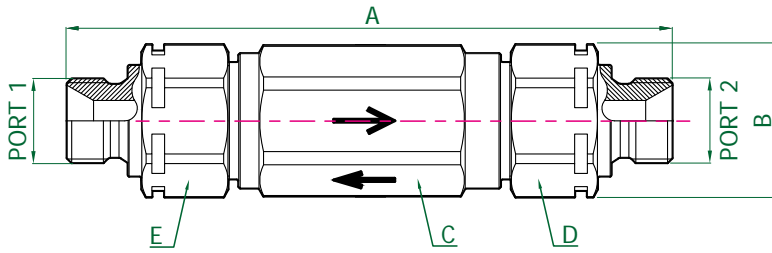

MALE-MALE, BI-DIRECTIONAL
INLET: BSP MALE 60° CONE SEAT
 BS5200 / ISO 8434-6
OUTLET: BSP MALE 60° CONE SEAT
 BS5200 / ISO 8434-6
MATERIAL: STEEL
SEALS: NBR (NITRILE)

NOMINAL SIZE			PART NUMBER	OPENING PRESSURE		THREADS		DIMENSIONS mm				
DN	inch	Dash		1 -> 2	2 -> 1	INLET	OUTLET	A	B	C	D	E
10	3/8"	-6	Q2D1110505N-06-06A	500 kPa	35 kPa	3/8"	3/8"	110.6	Ø30	27	27	27
10	3/8"	-6	Q2D1110505R-06-06A	800 kPa	35 kPa	3/8"	3/8"	110.6	Ø30	27	27	27
12.5	1/2"	-8	Q2D1110505N-08-08A	500 kPa	35 kPa	1/2"	1/2"	149.8	Ø38	34	34	34
12.5	1/2"	-8	Q2D1110505R-08-08A	800 kPa	35 kPa	1/2"	1/2"	149.8	Ø38	34	34	34
19	3/4"	-12	Q2D1110505N-12-12A	500 kPa	35 kPa	3/4"	3/4"	173.8	Ø45	41	41	41
19	3/4"	-12	Q2D1110505R-12-12A	800 kPa	35 kPa	3/4"	3/4"	173.8	Ø45	41	41	41

Q2D2110404

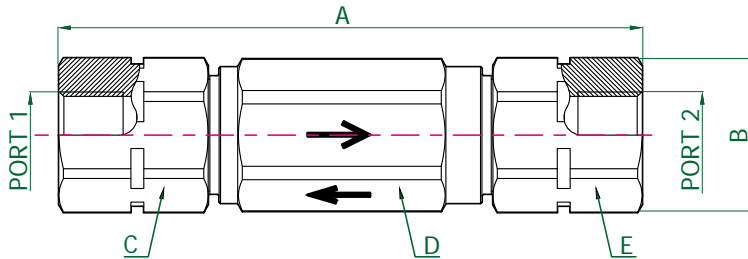

FEMALE-FEMALE, BI-DIRECTIONAL
INLET: BSP FIXED FEMALE
 DIN 3852-2 'FORM X' / ISO 1179-1
OUTLET: BSP FIXED FEMALE
 DIN 3852-2 'FORM X' / ISO 1179-1
MATERIAL: STEEL
SEALS: NBR (NITRILE)

NOMINAL SIZE			PART NUMBER	OPENING PRESSURE		THREADS		DIMENSIONS mm				
DN	inch	Dash		1 -> 2	2 -> 1	INLET	OUTLET	A	B	C	D	E
10	3/8"	-06	Q2D2110404N-06-06A	500 kPa	35 kPa	3/8"	3/8"	105.2	Ø30	27	27	27
10	3/8"	-06	Q2D2110404R-06-06A	800 kPa	35 kPa	3/8"	3/8"	105.2	Ø30	27	27	27
12.5	1/2"	-08	Q2D2110404N-08-08A	500 kPa	35 kPa	1/2"	1/2"	139.4	Ø38	34	34	34
12.5	1/2"	-08	Q2D2110404R-08-08A	800 kPa	35 kPa	1/2"	1/2"	139.4	Ø38	34	34	34
19	3/4"	-12	Q2D2110404N-12-12A	500 kPa	35 kPa	3/4"	3/4"	163.4	Ø45	41	41	41
19	3/4"	-12	Q2D2110404R-12-12A	800 kPa	35 kPa	3/4"	3/4"	163.4	Ø45	41	41	41

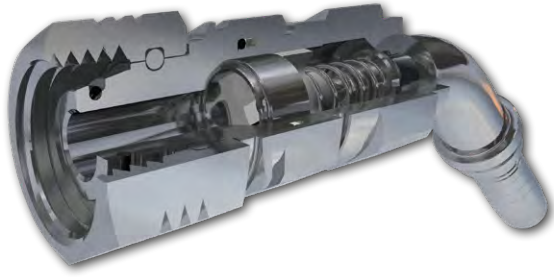

STANDARD CHECK VALVES DHI (DIRECT HOSE INTERFACE)

Pressure Drop

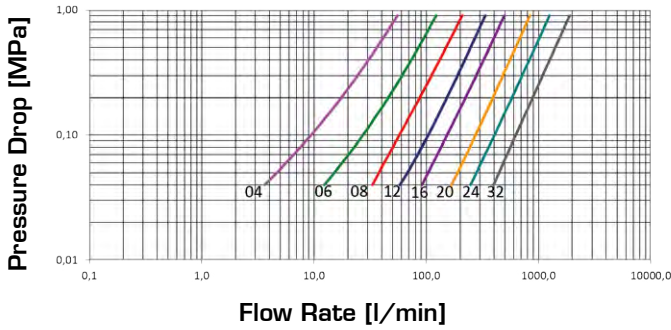

Pressure Drop

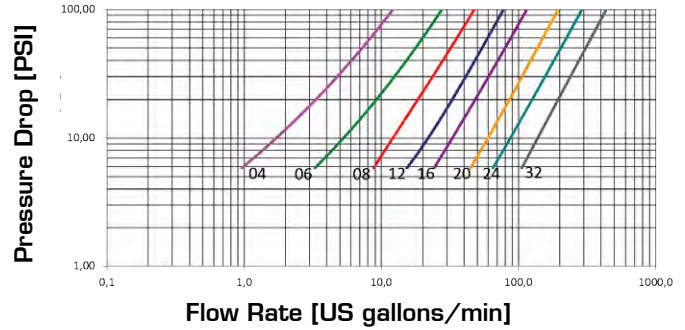

Q.SAFE 518

TECHNICAL DATA

SIZE			WORKING PRESSURE (Dynamic)		RATED FLOW at 0.2 MPa of pressure drop		MINIMUM BURST PRESSURE	
DN	inch	Dash	MPa	PSI	l/min	US GPM	MPa	PSI
6	1/4"	04	45	6525	18	4.8	180	26100
10	3/8"	06	35	5075	46	12.2	140	20300
12	1/2"	08	35	5075	88	23.2	140	20300
19	3/4"	12	35	5075	153	40.4	140	20300
25	1"	16	35	5075	225	59.4	140	20300
31	1.1/4"	20	35	5075	394	104.1	140	20300
38	1.1/2"	24	35	5075	580	153.2	140	20300
51	2"	32	35	5075	890	235.1	140	20300

PRODUCT DESCRIPTION

- Manufactured from high-quality materials
- Robust design
- Large range of termination end options available
- Large range of cracking-pressures available
- Direct-to-hose connection minimises potential leak points

MATERIAL

Steel, with springs in C98 high-carbon steel. Seals in NBR and back-up ring in PTFE.

WORKING TEMPERATURE

-22°F up to +230°F (-30°C up to +110°C)

SAFETY FACTOR

4:1 for dynamic pressures

IMPULSE PRESSURES

1,000,000 cycles at 120% of the rated one (freq. 1Hz)

TEST SPECIFICATIONS

ISO 18869

Q2A311M108

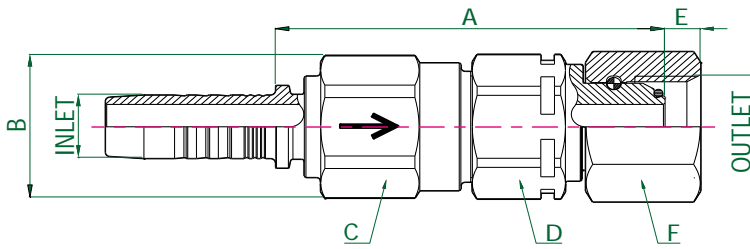

TAIL-FEMALE, STANDARD
INLET: MULTIFIT TAIL, STRAIGHT
OUTLET: BSP O-RING FEMALE
 60° CONE BS5200 / ISO 8434-6
MATERIAL: STEEL
SEALS: NBR (NITRILE)

NOMINAL SIZE			PART NUMBER	OPENING PRESSURE	THREADS		DIMENSIONS mm					
DN	inch	Dash			INLET	OUTLET	A	B	C	D	E	F
6	1/4"	-4	Q2A311M108A-04-04	35 kPa	1/4"	1/4"	50.2	Ø21	19	19	4.1	19
10	3/8"	-6	Q2A311M108A-06-06	35 kPa	3/8"	3/8"	62.3	Ø24,2	22	22	5.9	22
12.5	1/2"	-8	Q2A311M108A-08-08	35 kPa	1/2"	1/2"	70.9	Ø30	27	27	6.5	27
19	3/4"	-12	Q2A311M108A-12-12	35 kPa	3/4"	3/4"	80.6	Ø38	34	34	8.5	32
25	1"	-16	Q2A311M108A-16-16	35 kPa	1"	1"	86.9	Ø45	41	41	10.6	38

Q2A311M105

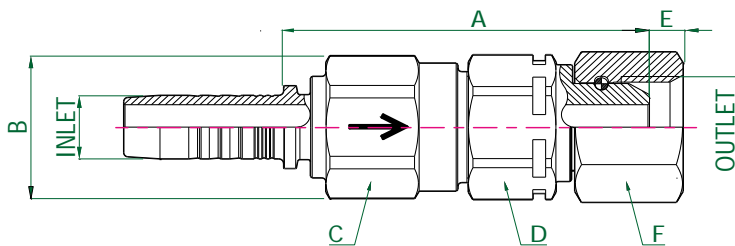

TAIL-FEMALE, STANDARD
INLET: MULTIFIT TAIL, STRAIGHT
OUTLET: BSP FEMALE 60° CONE
 BS5200 / ISO 8434-6
MATERIAL: STEEL
SEALS: NBR (NITRILE)

NOMINAL SIZE			PART NUMBER	OPENING PRESSURE	THREADS		DIMENSIONS mm					
DN	inch	Dash			INLET	OUTLET	A	B	C	D	E	F
31	1-1/4"	-20	Q2A311M105A-20-20	35 kPa	1-1/4"	1-1/4"	111.2	Ø55	50	50	10.5	50
38	1-1/2"	-24	Q2A311M105A-24-24	35 kPa	1-1/2"	1-1/2"	126	Ø66	60	60	12.5	60

Q.SAFE
519

Q2A41108M1

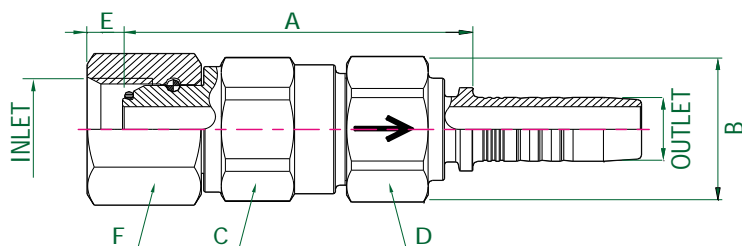

FEMALE-TAIL, STANDARD
INLET: BSP O-RING FEMALE
 60° CONE BS5200 / ISO 8434-6
OUTLET: MULTIFIT TAIL, STRAIGHT
MATERIAL: STEEL
SEALS: NBR (NITRILE)

NOMINAL SIZE			PART NUMBER	OPENING PRESSURE	THREADS		DIMENSIONS mm					
DN	inch	Dash			INLET	OUTLET	A	B	C	D	E	F
6	1/4"	-4	Q2A41108M1A-04-04	35 kPa	1/4"	1/4"	48	Ø21	19	19	4.1	19
10	3/8"	-6	Q2A41108M1A-06-06	35 kPa	3/8"	3/8"	57.3	Ø24,2	22	22	5.9	22
12.5	1/2"	-8	Q2A41108M1A-08-08	35 kPa	1/2"	1/2"	64.3	Ø30	27	27	6.5	27
19	3/4"	-12	Q2A41108M1A-12-12	35 kPa	3/4"	3/4"	73.4	Ø38	34	34	8.5	32
25	1"	-16	Q2A41108M1A-16-16	35 kPa	1"	1"	84.4	Ø45	41	41	10.6	38

Q.SAFE 520

Q2A41105M1

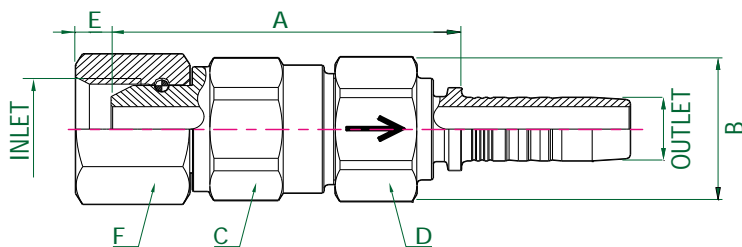

FEMALE-TAIL, STANDARD
INLET: BSP FEMALE 60° CONE
 BS5200 / ISO 8434-6
OUTLET: MULTIFIT TAIL, STRAIGHT
MATERIAL: STEEL
SEALS: NBR (NITRILE)

NOMINAL SIZE			PART NUMBER	OPENING PRESSURE	THREADS		DIMENSIONS mm					
DN	inch	Dash			INLET	OUTLET	A	B	C	D	E	F
31	1-1/4"	-20	Q2A41105M1A-20-20	35 kPa	1-1/4"	1-1/4"	111.2	Ø55	50	50	10.5	50
38	1-1/2"	-24	Q2A41105M1A-24-24	35 kPa	1-1/2"	1-1/2"	126	Ø66	60	60	12.5	60

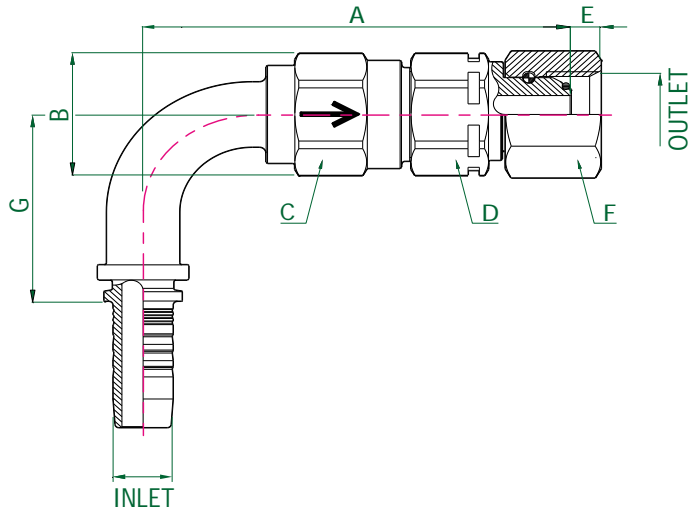

Q2A311M908

TAIL-FEMALE, STANDARD
INLET: MULTIFIT TAIL, 90° SWEPT
OUTLET: BSP O-RING FEMALE
 60° CONE BS5200 / ISO 8434-6
MATERIAL: STEEL
SEALS: NBR (NITRILE)

NOMINAL SIZE			PART NUMBER	OPENING PRESSURE	THREADS		DIMENSIONS mm						
DN	inch	Dash			INLET	OUTLET	A	B	C	D	E	F	G
6	1/4"	-4	Q2A311M908A-04-04	35 kPa	1/4"	1/4"	64.8	Ø21	19	19	4.1	19	30.1
10	3/8"	-6	Q2A311M908A-06-06	35 kPa	3/8"	3/8"	79.9	Ø24	22	22	5.9	22	37
12.5	1/2"	-8	Q2A311M908A-08-08	35 kPa	1/2"	1/2"	94.5	Ø30	27	27	6.5	27	45.9
19	3/4"	-12	Q2A311M908A-12-12	35 kPa	3/4"	3/4"	115.8	Ø38	34	34	8.5	32	62.5
25	1"	-16	Q2A311M908A-16-16	35 kPa	1"	1"	132	Ø45	41	41	10.6	38	70.6

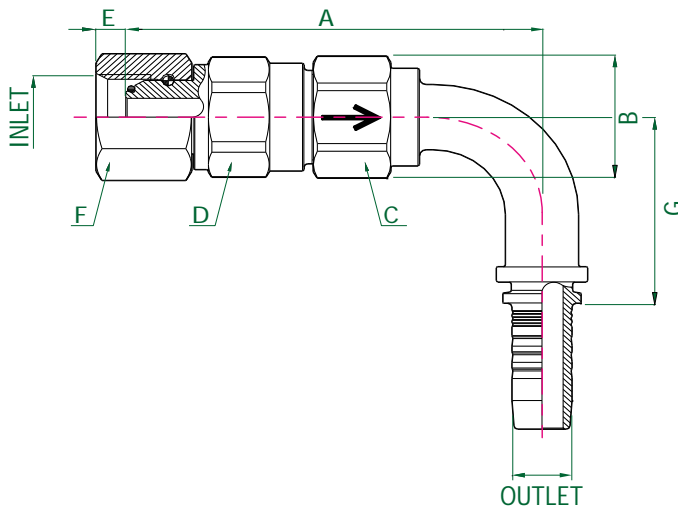

Q2A41108M9

TAIL-FEMALE, STANDARD
INLET: BSP O-RING FEMALE
 60° CONE BS5200 / ISO 8434-6
OUTLET: MULTIFIT TAIL, 90° SWEPT
MATERIAL: STEEL
SEALS: NBR (NITRILE)

NOMINAL SIZE			PART NUMBER	OPENING PRESSURE	THREADS		DIMENSIONS mm						
DN	inch	Dash			INLET	OUTLET	A	B	C	D	E	F	G
6	1/4"	-4	Q2A41108M9A-04-04	35 kPa	1/4"	1/4"	62.6	Ø21	19	19	4.1	19	30.1
10	3/8"	-6	Q2A41108M9A-06-06	35 kPa	3/8"	3/8"	74.9	Ø24	22	22	5.9	22	37
12.5	1/2"	-8	Q2A41108M9A-08-08	35 kPa	1/2"	1/2"	88	Ø30	27	27	6.5	27	45.9
19	3/4"	-12	Q2A41108M9A-12-12	35 kPa	3/4"	3/4"	108.6	Ø38	34	34	8.5	32	62.5
25	1"	-16	Q2A41108M9A-16-16	35 kPa	1"	1"	129.5	Ø45	41	41	10.6	38	70.6



BI-DIRECTIONAL CHECK VALVES DHI (DIRECT HOSE INTERFACE)

TECHNICAL DATA

SIZE			WORKING PRESSURE (Dynamic)		RATED FLOW at 0.2 MPa of pressure drop		MINIMUM BURST PRESSURE	
DN	inch	Dash	MPa	PSI	l/min	US GPM	MPa	PSI
10	3/8"	06	35	5075	39	10	150	21750
12.5	1/2"	08	35	5075	84	22	140	20300
19	3/4"	-12	35	5075	119	31	140	20300

PRODUCT DESCRIPTION

- Manufactured from high-quality materials
- Robust design
- Large range of termination end options available
- A-B cracking pressures of 500kPa and 800kPa available
- B-A cracking pressure of 35kPa
- Direct-to-hose connection minimises potential leak points

MATERIAL

Steel, with springs in C98 high-carbon steel. Seals in NBR and back-up ring in PTFE.

WORKING TEMPERATURE

-22°F up to +230°F (-30°C up to +110°C)

SAFETY FACTOR

4:1 for dynamic pressures

IMPULSE PRESSURES

1,000,000 cycles at 120% of the rated one (freq. 1Hz)

TEST SPECIFICATIONS

ISO 18869

Q.SAFE 522

Q2D311M108

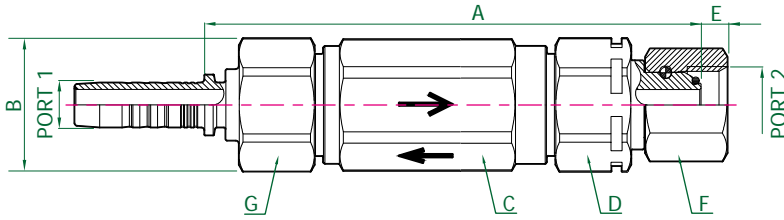

TAIL-FEMALE, BI-DIRECTIONAL
INLET: MULTIFIT TAIL, STRAIGHT
OUTLET: BSP O-RING FEMALE
 60° CONE BS5200 / ISO 8434-6
MATERIAL: STEEL
SEALS: NBR (NITRILE)

NOMINAL SIZE			PART NUMBER	OPENING PRESSURE		THREADS		DIMENSIONS mm						
DN	inch	Dash		1 -> 2	2 -> 1	INLET	OUTLET	A	B	C	D	E	F	G
10	3/8"	-6	Q2D311M108N-06-06A	500 kPa	35 kPa	3/8"	3/8"	104.9	Ø30	27	27	6	22	27
10	3/8"	-6	Q2D311M108R-06-06A	800 kPa	35 kPa	3/8"	3/8"	104.9	Ø30	27	27	6	22	27
12.5	1/2"	-8	Q2D311M108N-08-08A	500 kPa	35 kPa	1/2"	1/2"	139.8	Ø38	34	34	6.3	27	34
12.5	1/2"	-8	Q2D311M108R-08-08A	800 kPa	35 kPa	1/2"	1/2"	139.8	Ø38	34	34	6.3	27	34
19	3/4"	-12	Q2D311M108N-12-12A	500 kPa	35 kPa	3/4"	3/4"	163.7	Ø45	41	41	8.5	32	41
19	3/4"	-12	Q2D311M108R-12-12A	800 kPa	35 kPa	3/4"	3/4"	163.7	Ø45	41	41	8.5	32	41

Q2D41108M1

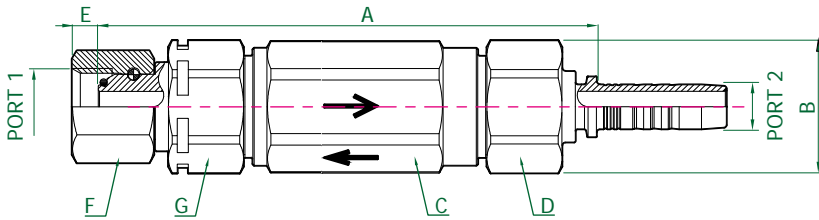

FEMALE-TAIL, BI-DIRECTIONAL
INLET: BSP O-RING FEMALE
 60° CONE BS5200 / ISO 8434-6
OUTLET: MULTIFIT TAIL, STRAIGHT
MATERIAL: STEEL
SEALS: NBR (NITRILE)

NOMINAL SIZE			PART NUMBER	OPENING PRESSURE		THREADS		DIMENSIONS mm						
DN	inch	Dash		1 -> 2	2 -> 1	INLET	OUTLET	A	B	C	D	E	F	G
10	3/8"	-6	Q2D41108M1N-06-06A	500 kPa	35 kPa	3/8"	3/8"	104.9	Ø30	27	27	6	22	27
10	3/8"	-6	Q2D41108M1R-06-06A	800 kPa	35 kPa	3/8"	3/8"	104.9	Ø30	27	27	6	22	27
12.5	1/2"	-8	Q2D41108M1N-08-08A	500 kPa	35 kPa	1/2"	1/2"	139.8	Ø38	34	34	6.3	27	34
12.5	1/2"	-8	Q2D41108M1R-08-08A	800 kPa	35 kPa	1/2"	1/2"	139.8	Ø38	34	34	6.3	27	34
19	3/4"	-12	Q2D41108M1N-12-12A	500 kPa	35 kPa	3/4"	3/4"	173.8	Ø45	41	41	8.5	32	41
19	3/4"	-12	Q2D41108M1R-12-12A	800 kPa	35 kPa	3/4"	3/4"	173.8	Ø45	41	41	8.5	32	41

Q.SAFE
523

Bespoke solutions to unique problems

*Hydraulics applications are so many and varied that it would be pretty much impossible to develop industrialised products for every possible situation. However, at Manuli Hydraulics we are fully prepared to meet any application challenge that our OEM partners can present us with, which is why we offer our **Bespoke Solutions Program (BSP)**.*

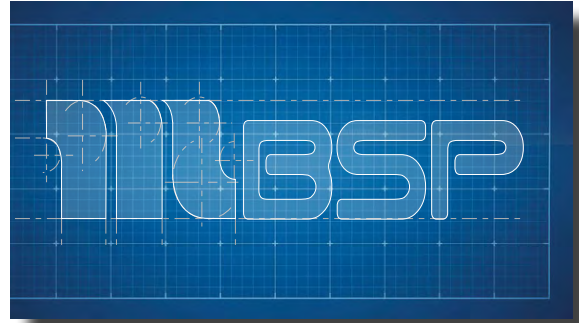

The BSP is just one way that Manuli Hydraulics provides an added value service to our OEM partners. Manuli Hydraulics is structured in such a way that we can tailor solutions to the specific requirements of our customers in a way that our competitors never could. We are small enough to be agile and responsive, yet large enough to have the design and manufacturing capabilities to produce bespoke products at a reasonable price. Used by some of the largest and most respected OEMs around the world, the Manuli Bespoke Solutions Program means that you never have to compromise on your hydraulic system design again.

How to specify your bespoke check valve

Specifying the required properties of your check valve is simply a matter of constructing an appropriate part number. The following pages explain how to construct the part number using the Manuli Hydraulics part numbering system.

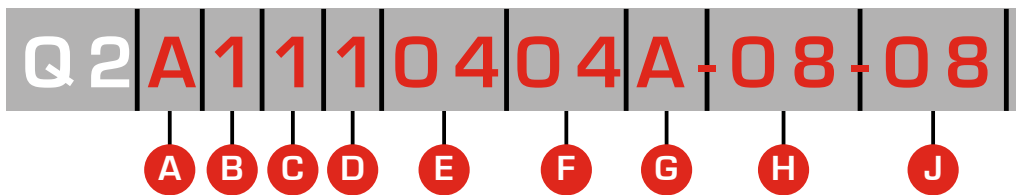

A - CHECK VALVE TYPE - See Table 1

B - INPUT / OUTPUT CONFIGURATION - See Table 2

C - VALVE MATERIAL - See Table 3

D - SEAL MATERIAL - See Table 4

E - INPUT TERMINATION END TYPE - See Table 5

F - OUTPUT TERMINATION END TYPE - See Table 5

G - CRACK PRESSURE - See Table 6

H - INPUT TUBE SIZE - See Table 7

J - OUTPUT TUBE SIZE - See Table 7

1 - CHECK VALVE TYPE

Digit	Check Valve Type
A	Standard
B	Compact
C	Calibrated
D	Bi-directional

2 - INLET / OUTLET CONFIGURATION

Digit	INLET	OUTLET
	Male / Tail*	Male / Tail*
1		
	Female	Female
2		
	Male / Tail*	Female
3		
	Female	Male / Tail*
4		

* Use Table 5a for male termination ends, and Table 5b for DHI tails

3 - VALVE MATERIAL

Digit	Material
1	Steel
2	AISI 316
3	AISI 303
4	Brass
5	Aluminium

4 - SEAL MATERIAL

Digit	INLET
0	None
1	NBR (Nitrile)
2	HNBR
3	FKM (Viton, FPM)
4	CR (Neoprene)
5	EPDM
6	FFPM (Kalrez)
7	PTFE
8	VMQ (Silicone Rubber)
9	AU (Polyurethane)

5 - INLET / OUTLET TERMINATION END TYPE

Digit	Male Termination End	Female Termination End
01	BSP Male DIN 3852-11 - ISO 1179-2 Heavy Duty "form E"	Fixed Female GAS JIS B 2351 "type O"
02	BSP Male Tapered Thread Long	BSP Female Tapered
04	BSP Male Bulkhead	BSP Fixed Female DIN 3852-2 "form X" / ISO 1179-1
05	BSP Male 60° cone seat BS5200 / ISO 8434-6	BSP Female 60° cone BS5200 / ISO 8434-6
08	Metric Bolt DIN 7643	BSP O-Ring Female 60° cone BS5200 / ISO 8434-6
11	Metric male 24° cone seat light type DIN 3861 / ISO 8434-1	-
12	Metric male 24° cone seat heavy type DIN 3861 / ISO 8434-1	Metric Female 24° cone O'Ring heavy type DIN 3865 / ISO 8434-1 Long Drop
14	Metric Male DIN 3852-11 "form E" b/ ISO 9974-2	Metric Fixed Female DIN 3852-1 "form X" and "form Y"
19	Metric Male ISO 6149-2 / DIN 3852-3 "form F" (only for Fittings and Q.Safe) Metric Male with Retaining Ring (Adjustable + Non-Adjustable Heavy) ISO 9974 port compatible (only for Adaptors)	Metric Fixed Female ISO 6149-1
23	JIC Bulkhead male 37° cone ISO 8434-2 / SAE J514	-
24	ORFS male ISO 8434-3 / SAE J1453	ORFS female ISO 8434-3 / SAE J1453
25	JIC male (37° cone) ISO 8434-2 / SAE J514	JIC female (37° cone seat) ISO 8434-2 / SAE J514
27	ORFS Bulkhead male ISO 8434-3 / SAE J1453	JIC female double hexagon 37° cone seat
28	NPTF Male 60° cone seat SAE J476a	NPSM Swivel Female 60° cone SAE J514
30	Male O'Ring Boss type SAE J1926-3	Female Port SAE J1926-1
32	Male O'Ring Boss (Adjustable + Non-Adjustable Heavy) SAE J1926-2	-
34	API Male	NPTF Fixed Female SAE J476a
37	Metric male 60° cone superlight DIN 3863 Bulkhead	Flange ISO/SAE 62 Plus / Flange (A/C)
77	DIN Bulkhead Male 24° cone Light type ISO 8434-1	ASME B16.5 Ring Joint Type Flange
82	French GAZ Bulkhead metric male 24° cone seat	Staple Lock Swivel Female
87	DIN Bulkhead Male 24° cone Heavy type ISO 8434-1	ASME B16.5 FLANGE / SDB compressor (A/C)

Table 5a - Termination End Options

Digit	DHI Tail Type
M1	Multifit tail, straight
M4	Multifit tail, 45° swept
M9	Multifit Plus tail, 90° swept
I1	Interlock Plus tail, straight
I4	Interlock Plus tail, 45° swept
I9	Interlock Plus tail, 90° swept
S1	Spiralfit tail, straight
S4	Spiralfit tail, 45° swept
S9	Spiralfit tail, 90° swept

Table 5b - DHI Tail Options

6 - CRACK PRESSURE

Digit	Pressure (kPa)	Pressure (psi)
A	35	5.1
B	10	1.5
C	20	2.9
D	50	7.3
E	100	14.5
F	150	21.8
G	200	29.0
H	250	36.3
J	300	43.5
K	350	50.8
L	400	58.0
M	450	65.3
N	500	72.5
P	600	87.0
Q	700	101.5
R	800	116.0
S	900	130.5
T	1000	145.0
X	Without Spring	

7 - INLET / OUTLET TUBE SIZE

Digit	DN	Inch	Dash
04	6	1/4"	-04
06	10	3/8"	-06
08	12	1/2"	-08
10	16	5/8"	-10
12	19	3/4"	-12
16	25	1"	-16
20	31	1-1/4"	-20
22	35	1-3/8"	-22
24	38	1-1/2"	-24
32	51	2"	-32
36	57	2-1/4"	-36